



USBDFxxW5

A.S.D.™

EMI FILTER AND LINE TERMINATION FOR USB DOWNSTREAM PORTS

APPLICATIONS

EMI Filter and line termination for USB downstream ports on:

- Desktop computer
- Notebooks
- Workstations
- USB Hubs

FEATURES

- Monolithic device with recommended line termination for USB downstream ports
- Integrated R_t series termination and C_t bypassing capacitors.
- Integrated ESD protection
- Small package size

DESCRIPTION

The USB specification requires USB downstream ports to be terminated with pull-down resistors from the D+ and D- lines to ground. On the implementation of USB systems, the radiated and conducted EMI should be kept within the required levels as stated by the FCC regulations. In addition to the requirements of termination and EMC compatibility, the computing devices are required to be tested for ESD susceptibility.

The USBDFxxW5 provides the recommended line termination while implementing a low pass filter to limit EMI levels and providing ESD protection which exceeds IEC 61000-4-2 level 4 standard. The device is packaged in a SOT323-5L which is the smallest available lead frame package (50% smaller than the standard SOT23).

BENEFITS

- EMI / RFI noise suppression
- Required line termination for USB downstream ports
- ESD protection exceeding IEC61000-4-2 level 4
- High flexibility in the design of high density boards
- Tailored to meet USB 1.1 standard

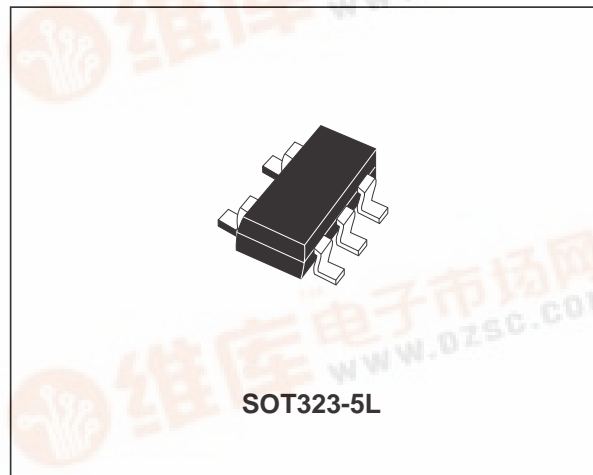

FUNCTIONAL DIAGRAM

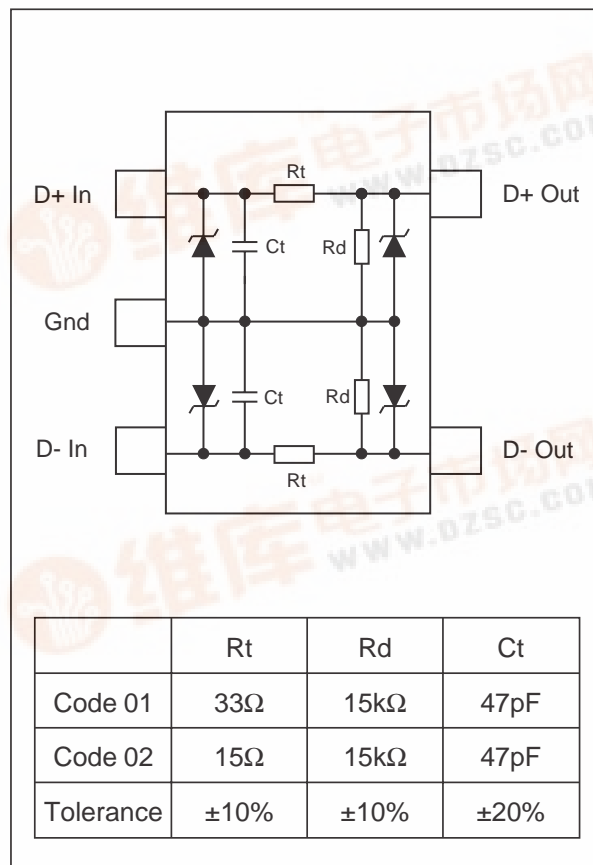

TM: ASD and TRANSIL are trademarks of STMicroelectronics.



USBDFxxW5

COMPLIES WITH THE FOLLOWING ESD STANDARDS:

IEC-61000-4-2, level 4

±15 kV (air discharge)

±8 kV (contact discharge)

MIL STD 883C, Method 3015-6

Class 3 C = 100 pF R = 1500 Ω

3 positive strikes and 3 negative strikes (F = 1 Hz)

ABSOLUTE MAXIMUM RATINGS (T_{amb} = 25°C)

| Symbol | Parameter | Value | Unit |
|------------------|---|--------------|----------|
| V _{PP} | ESD discharge IEC 61000-4-2, contact discharge ESD discharge - MIL STD 883 - Method 3015-6 | ±15 ±25 | kV kV |
| T _j | Junction temperature | 150 | °C |
| T _{stg} | Storage temperature range | - 55 to +150 | °C |
| T _L | Lead solder temperature (10 second duration) | 260 | °C |
| T _{op} | Operating temperature Range | 0 to 70 | °C |
| P _r | Power rating per resistor | 100 | mW |

ELECTRICAL CHARACTERISTICS (T_{amb} = 25°C)

| Symbol | Parameters | Test conditions | Min | Typ | Max | Unit |
|-----------------|----------------------------|-----------------------|-----|-----|-----|------|
| V _{BR} | Diode breakdown voltage | I _R = 1mA | 6 | | | V |
| V _F | Diode forward voltage drop | I _F = 50mA | | 0.9 | | V |

APPLICATION INFORMATION

Fig. A1: USB Standard requirements

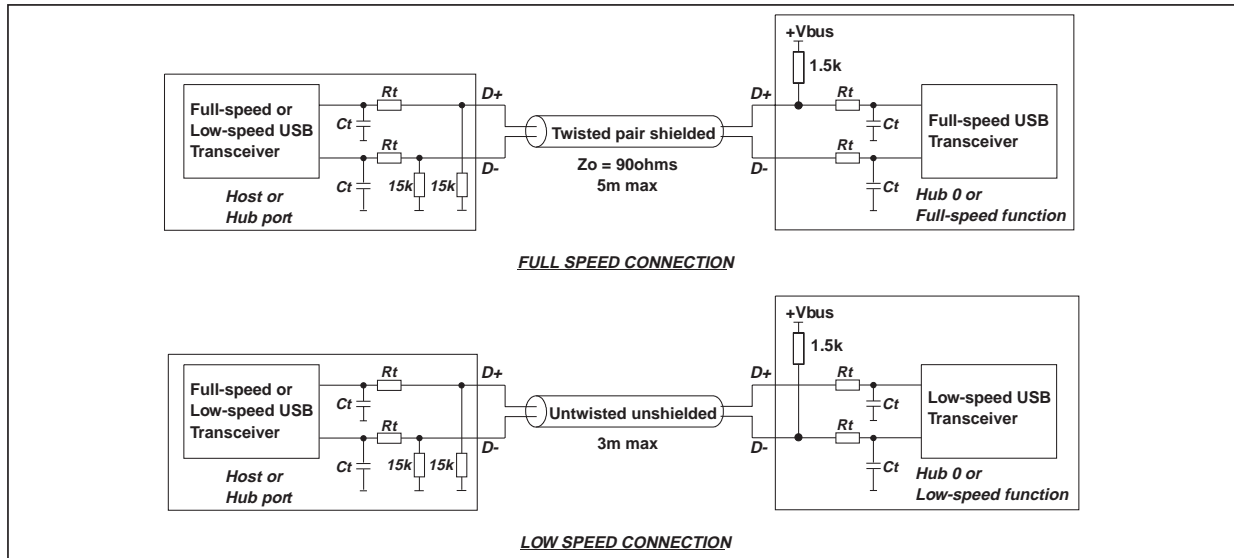

APPLICATION EXAMPLE

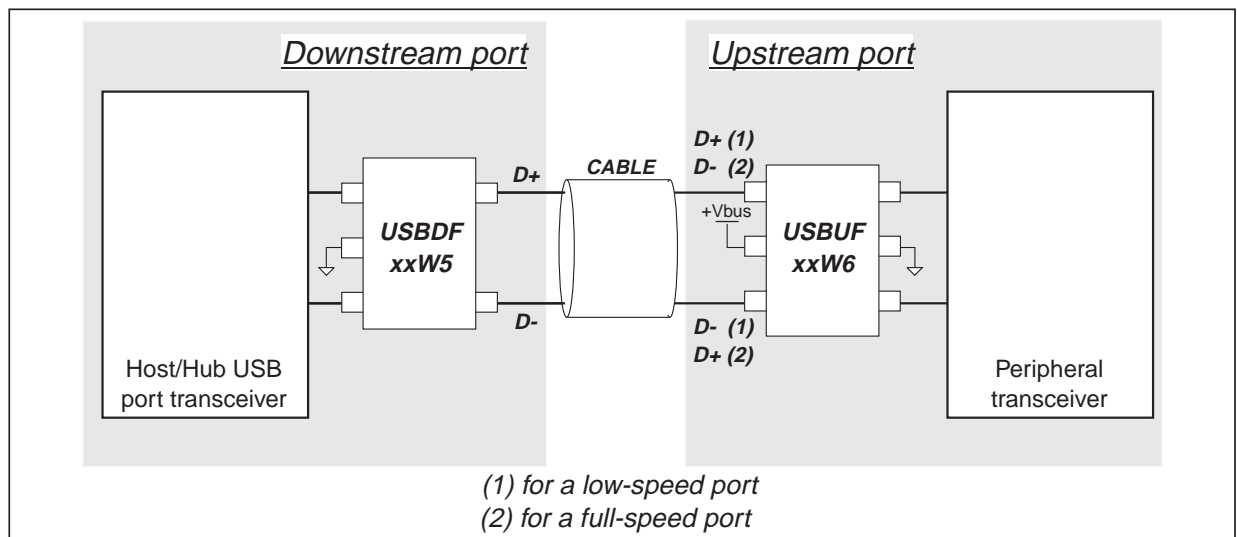

USBDFxxW5

EMI FILTERING

Current FCC regulations requires that class B computing devices meet specified maximum levels for both radiated and conducted EMI.

- Radiated EMI covers the frequency range from 30MHz to 1GHz.
- Conducted EMI covers the 450kHz to 30MHz range.

For the types of devices utilizing the USB the most difficult test to pass is usually the radiated EMI test. For this reason the USBDF device is aiming to minimize radiated EMI.

The differential signal (D+ and D-) of the USB does not contribute significantly to radiated or conducted EMI because the magnetic field of the two conductors exactly cancels each other.

The inside of the PC environment is very noisy and designers must minimise noise coupling from the different sources. D+ and D- must not be routed near high speed lines (clocks...).

Induced common mode noise can be minimised by running pairs of USB signals parallel to each other and running grounded guard trace on each side of the signal pair from the USB controller to the USBDF device.

If possible, locate the USBDF device physically near the USB connectors. Distance between the USB controller and the USB connector must be minimized.

The 47pF (Ct) capacitors are used to bypass high frequency energy to ground and for edge control, and must be placed between the USB Controller and the series termination resistors (Rt). Both Ct and Rt should be placed as close to the USB Controller as practicable.

The USBDFxxW5 ensure a filtering protection against ElectroMagnetic and RadioFrequency Interferences thanks to its low-pass filter structure. This filter is characterized by the following parameters :

- cut-off frequency
- Insertion loss
- high frequency rejection

Fig. A3 shows the attenuation curve for frequencies up to 3GHz.

Fig. A2: Measurement configuration

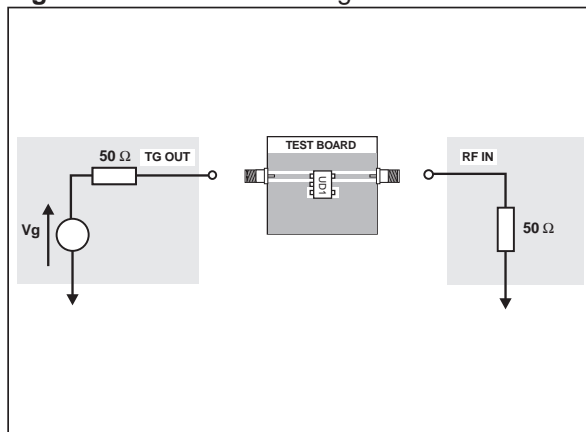
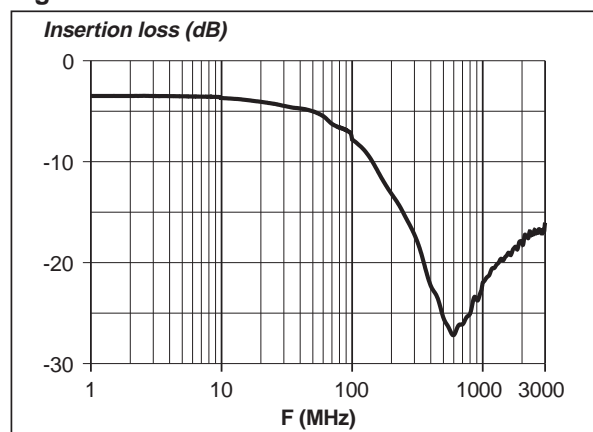

Fig. A3: USBDFxxW5 attenuation curve.



ESD PROTECTION

In addition to the requirements of termination and EMC compatibility, computing devices are required to be tested for ESD susceptibility. This test is described in the IEC 61000-4-2 and is already in place in Europe. This test requires that a device tolerates ESD events and remain operational without user intervention.

The USBDFxxW5 is particularly optimized to perform ESD protection. ESD protection is based on the use of device which clamps at :

$$V_{input} = V_{BR} + R_d \cdot I_{PP}$$

This protection function is splitted in 2 stages. As shown in figure A4, the ESD strikes are clamped by the first stage S1 and then its remaining overvoltage is applied to the second stage through the resistor R. Such a configuration makes the output voltage very low at the V_{out} level.

Fig. A4: USBDFxxW5 ESD clamping behavior

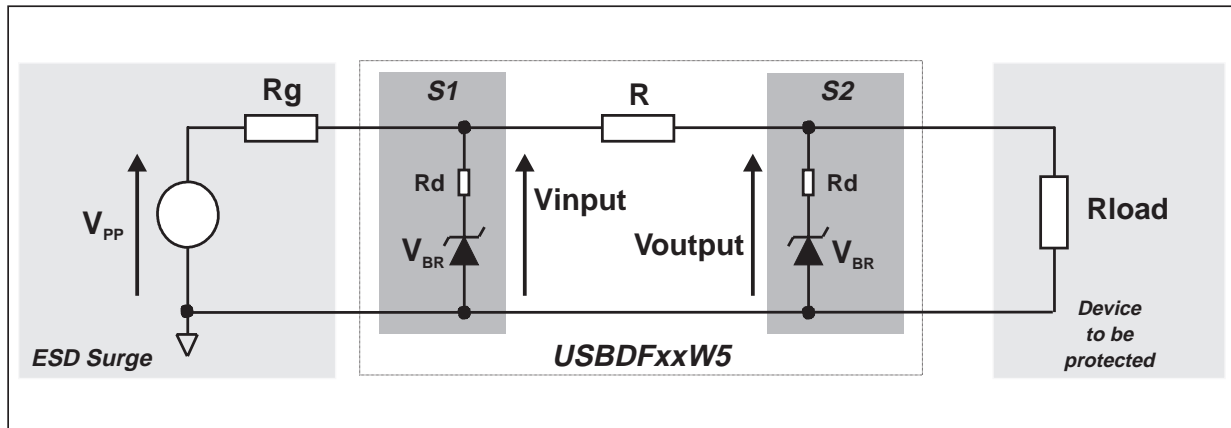

To have a good approximation of the remaining voltages at both Vin and Vout stages, we give the typical dynamical resistance value Rd. By taking into account these following hypothesis : $R_t > R_d$, $R_g > R_d$ and $R_{load} > R_d$, it gives these formulas:

$$V_{input} = \frac{R_g \cdot V_{BR} + R_d \cdot V_g}{R_g}$$

$$V_{output} = \frac{R_t \cdot V_{BR} + R_d \cdot V_{input}}{R_t}$$

The results of the calculation done for $V_{PP}=8kV$, $R_g=330\Omega$ (IEC61000-4-2 standard), $V_{BR}=7V$ (typ.) and $R_d = 1\Omega$ (typ.) give:

$$V_{input} = 31.2 V$$

$$V_{output} = 7.95 V$$

This confirms the very low remaining voltage across the device to be protected. It is also important to note that in this approximation the parasitic inductance effect was not taken into account. This could be few tenths of volts during few ns at the Vin side. This parasitic effect is not present at the Vout side due the low current involved after the resistance R.

The measurements done here after show very clearly (Fig. A6) the high efficiency of the ESD protection :

- no influence of the parasitic inductances on Vout stage
- output clamping voltage very close to V_{BR} (positive strike) and $-V_F$ (negative strike)

Fig. A5: Measurement board

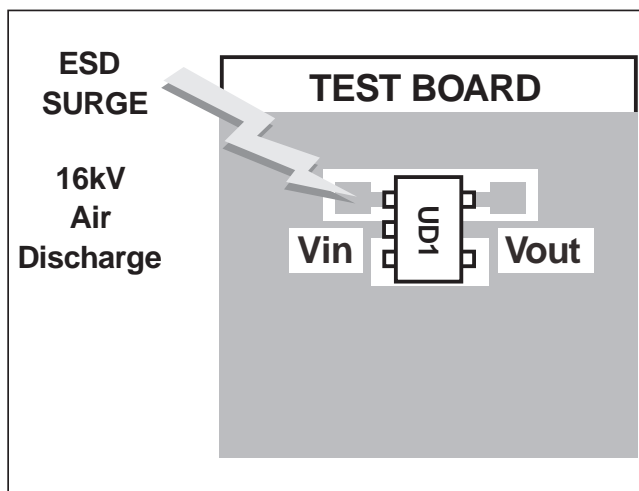

USBDFxxW5

Fig. A6: Remaining voltage at both stages S1 (Vinput) and S2 (Voutput) during ESD surge.

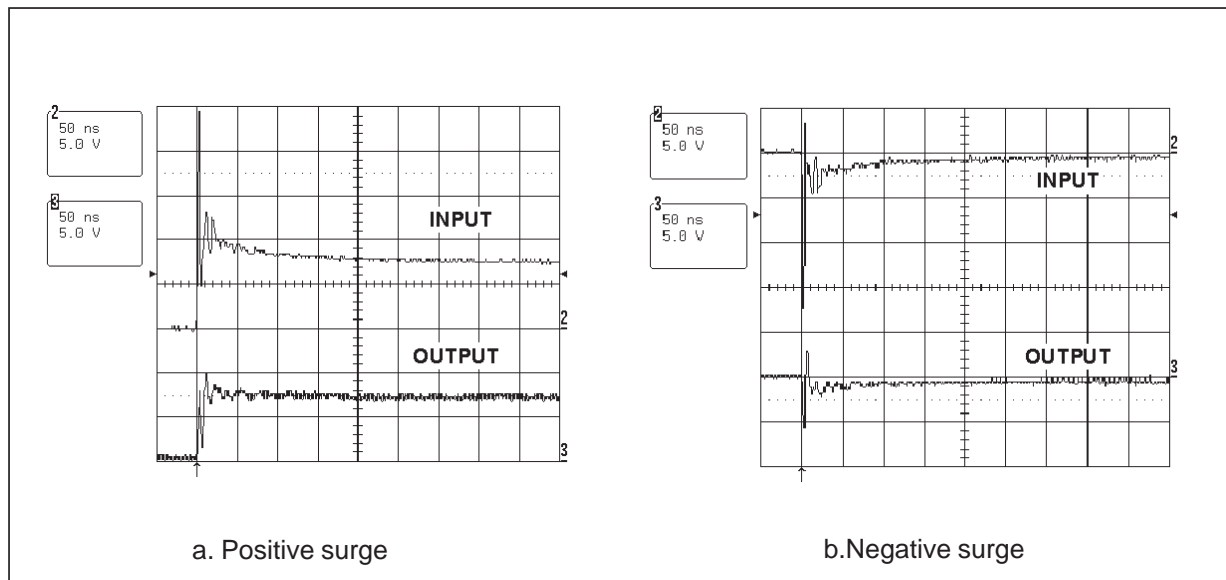

Please note that the USBDFxxW5 is not only acting for positive ESD surges but also for negative ones. For these kinds of disturbances it clamps close to ground voltage as shown in Fig. A6b.

LATCH-UP PHENOMENA

The early ageing and destruction of IC's is often due to latch-up phenomena which is mainly induced by dV/dt . Thanks to its structure, the USBDFxxW5 provides a high immunity to latch-up phenomena by smoothing very fast edges.

CROSSTALK BEHAVIOR

Fig. A7: Crosstalk phenomena

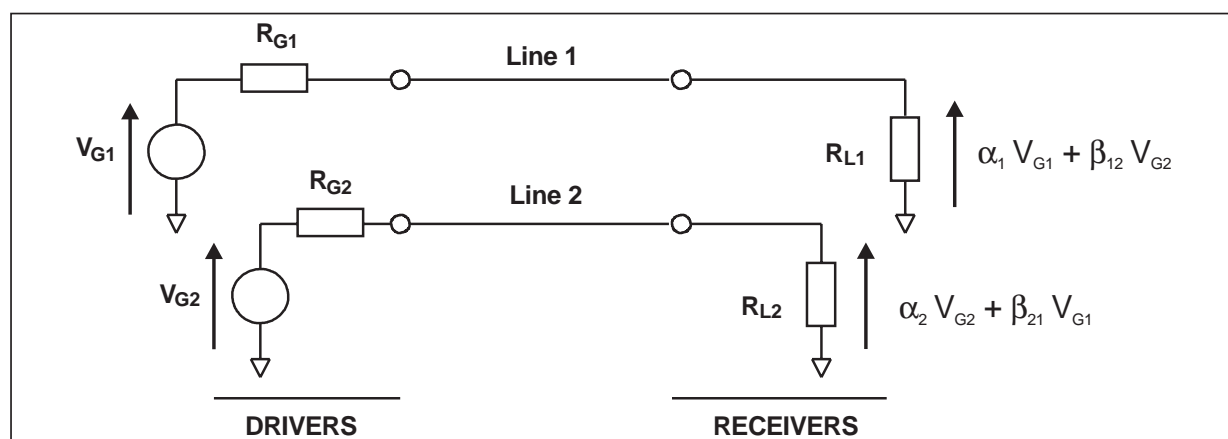

The crosstalk phenomena is due to the coupling between 2 lines. The coupling factor (β_{12} or β_{21}) increases when the gap across lines decreases, this is the reason why we provide crosstalk measurements for monolithic device to guarantee negligible crosstalk between the lines. In the example above the expected signal on load R_{L2} is $\alpha_2 V_{G2}$, in fact the real voltage at this point has got an extra value $\beta_{21} V_{G1}$. This part of the V_{G1} signal represents the effect of the crosstalk phenomenon of the line 1 on the line 2. This phenomenon has to be taken into account when the drivers impose fast digital data or high frequency analog signals in the disturbing line. The perturbed line will be more affected if it works with low voltage signal or high load impedance (few $k\Omega$).

Fig. A8: Analog Crosstalk measurements

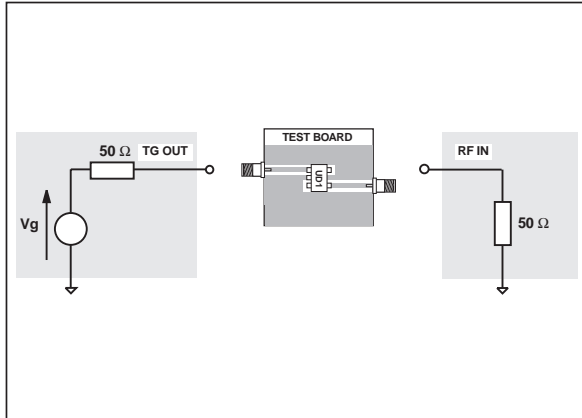

Fig. A9: Typical Analog Crosstalk results

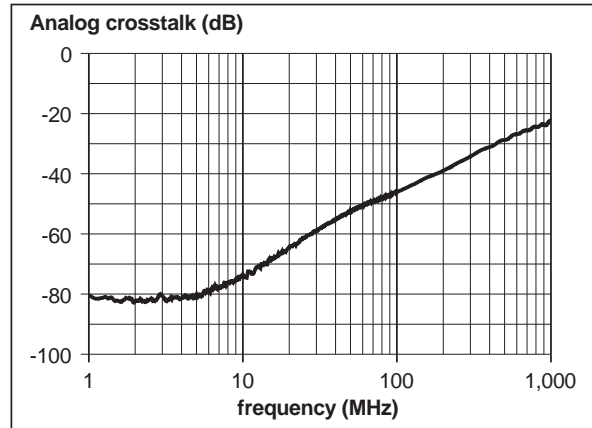

Figure A8 gives the measurement circuit for the analog crosstalk application. In figure A9, the curve shows the effect of the D+ cell on the D- cell. In usual frequency range of analog signals (up to 100MHz) the effect on disturbed line is less than -46dB.

Fig. A10: Digital crosstalk measurements configuration

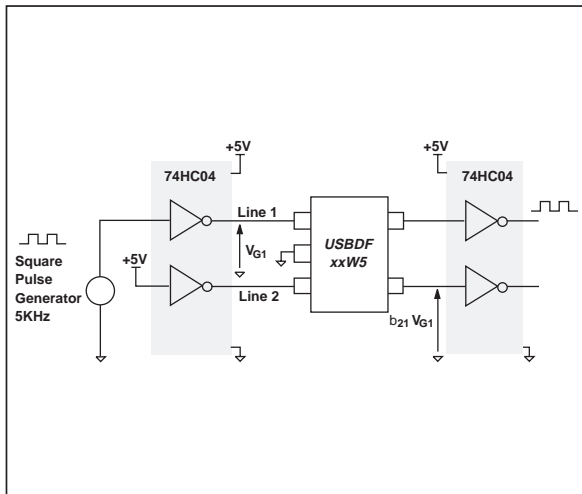

Fig. A11: Digital crosstalk results

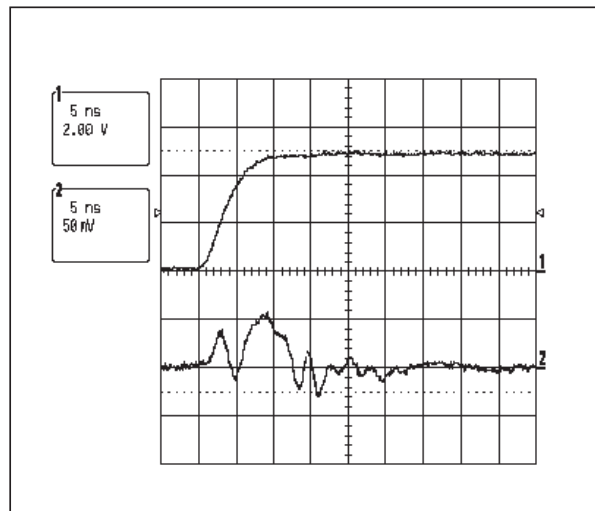

Figure A10 shows the measurement circuit used to quantify the crosstalk effect in a classical digital application.

Figure A11 shows that in such a condition signal from 0 to 5V and rise time of few ns, the impact on the other line is less than 100mV peak to peak (Below the logic high voltage threshold).The measurements performed with falling edges give the same results.

USBDFxxW5

TRANSITION TIMES

This low pass filter has been designed in order to meet the USB 1.1 standard requirements that implies the signal edges are maintained within the 4ns-20ns stipulated USB specification limits.

Fig. A12: Typical rise and fall times: measurements configuration

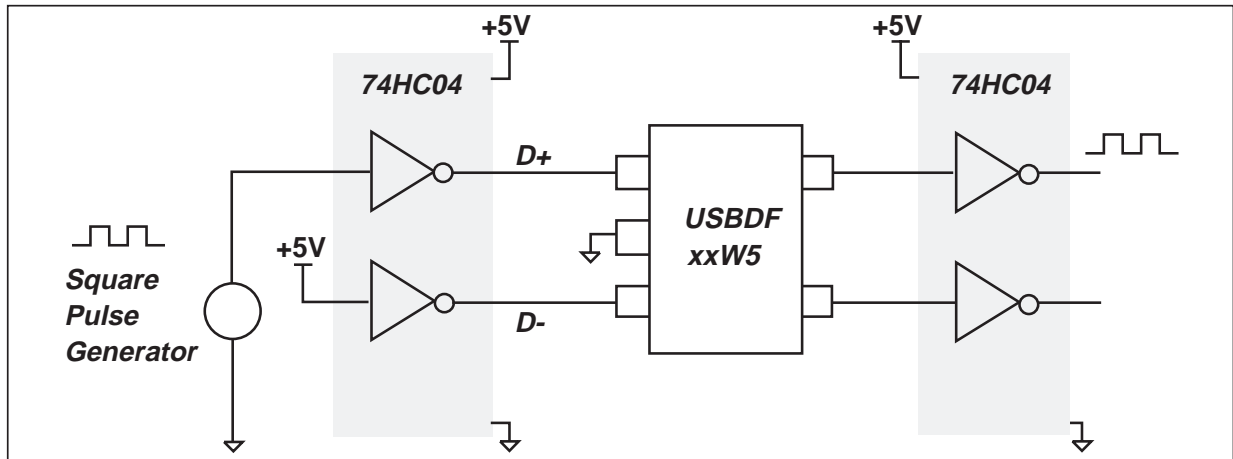
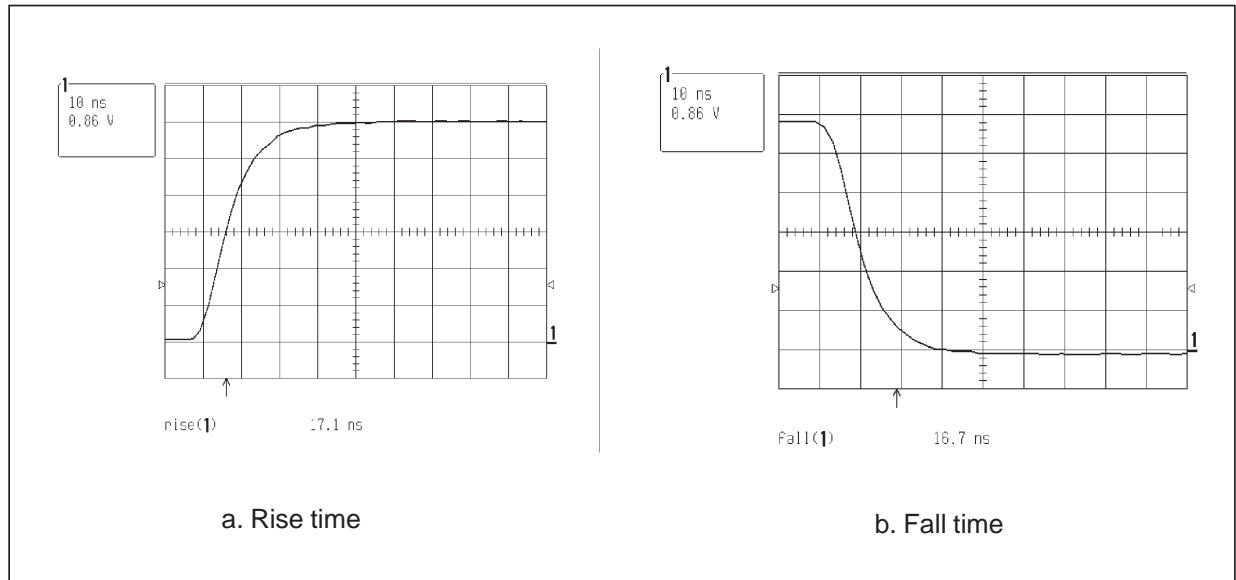

Fig. A13: Typical rise and fall times



USBDFxxW5

PACKAGE MECHANICAL DATA. SOT323-5L

| REF. | DIMENSIONS | | | |
|------|-------------|------|------------|-------|
| | Millimeters | | Inches | |
| | Min. | Max. | Min. | Max. |
| A | 0.8 | 1.1 | 0.031 | 0.043 |
| A1 | 0 | 0.1 | 0 | 0.004 |
| A2 | 0.8 | 1 | 0.031 | 0.039 |
| b | 0.15 | 0.3 | 0.006 | 0.012 |
| c | 0.1 | 0.18 | 0.004 | 0.007 |
| D | 1.8 | 2.2 | 0.071 | 0.086 |
| E | 1.15 | 1.35 | 0.045 | 0.053 |
| e | 0.65 Typ. | | 0.025 Typ. | |
| H | 1.8 | 2.4 | 0.071 | 0.094 |
| Q1 | 0.1 | 0.4 | 0.004 | 0.016 |

RECOMMENDED FOOTPRINT (mm)

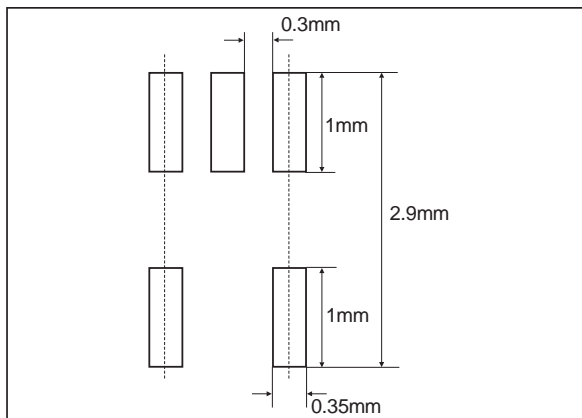

MECHANICAL SPECIFICATIONS

| | |
|------------------------|---------------------------|
| Lead plating | Tin-lead |
| Lead plating thickness | 5µm min 25µm max |
| Lead material | Sn / Pb (70% to 90%Sn) |
| Lead coplanarity | 10µm max |
| Body material | Molded epoxy |
| Flammability | UL94V-0 |

MARKING

| Type | Order Code | Weight | Marking | Package | Base Qty |
|-----------|------------|--------|---------|-----------|----------|
| USBDF01W5 | USBDF01W5 | 5.4mg | UD1 | SOT323-5L | 3000 |
| USBDF02W5 | USBDF02W5 | | UD2 | | |

Information furnished is believed to be accurate and reliable. However, STMicroelectronics assumes no responsibility for the consequences of use of such information nor for any infringement of patents or other rights of third parties which may result from its use. No license is granted by implication or otherwise under any patent or patent rights of STMicroelectronics. Specifications mentioned in this publication are subject to change without notice. This publication supersedes and replaces all information previously supplied. STMicroelectronics products are not authorized for use as critical components in life support devices or systems without express written approval of STMicroelectronics.

The ST logo is a registered trademark of STMicroelectronics

© 2000 STMicroelectronics - Printed in Italy - All rights reserved.

STMicroelectronics GROUP OF COMPANIES

Australia - Brazil - China - Finland - France - Germany - Hong Kong - India - Italy - Japan - Malaysia
Malta - Morocco - Singapore - Spain - Sweden - Switzerland - United Kingdom - U.S.A.

<http://www.st.com>