



# HIGH-SPEED 3.3V 512K x 18 SYNCHRONOUS BANK-SWITCHABLE DUAL-PORT STATIC RAM WITH 3.3V OR 2.5V INTERFACE

IDT70V7339S

## Features:

- ◆ 512K x 18 Synchronous Bank-Switchable Dual-ported SRAM Architecture
  - 64 independent 8K x 18 banks
  - 9 megabits of memory on chip
- ◆ Bank access controlled via bank address pins
- ◆ High-speed data access
  - Commercial: 3.4ns (200MHz)/3.6ns (166MHz)/4.2ns (133MHz) (max.)
  - Industrial: 3.6ns (166MHz)/4.2ns (133MHz) (max.)
- ◆ Selectable Pipelined or Flow-Through output mode
- ◆ Counter enable and repeat features
- ◆ Dual chip enables allow for depth expansion without additional logic
- ◆ Full synchronous operation on both ports
  - 5ns cycle time, 200MHz operation (14Gbps bandwidth)
  - Fast 3.4ns clock to data out

- 1.5ns setup to clock and 0.5ns hold on all control, data, and address inputs @ 200MHz
- Data input, address, byte enable and control registers
- Self-timed write allows fast cycle time
- ◆ Separate byte controls for multiplexed bus and bus matching compatibility
- ◆ LVTTTL-compatible, 3.3V (±150mV) power supply for core
- ◆ LVTTTL compatible, selectable 3.3V (±150mV) or 2.5V (±100mV) power supply for I/Os and control signals on each port
- ◆ Industrial temperature range (-40°C to +85°C) is available at 166MHz and 133MHz
- ◆ Available in a 144-pin Thin Quad Flatpack (TQFP), 208-pin fine pitch Ball Grid Array (fpBGA), and 256-pin Ball Grid Array (BGA)
- ◆ Supports JTAG features compliant with IEEE 1149.1
  - Due to limited pin count, JTAG is not supported on the 144-pin TQFP package.

## Functional Block Diagram

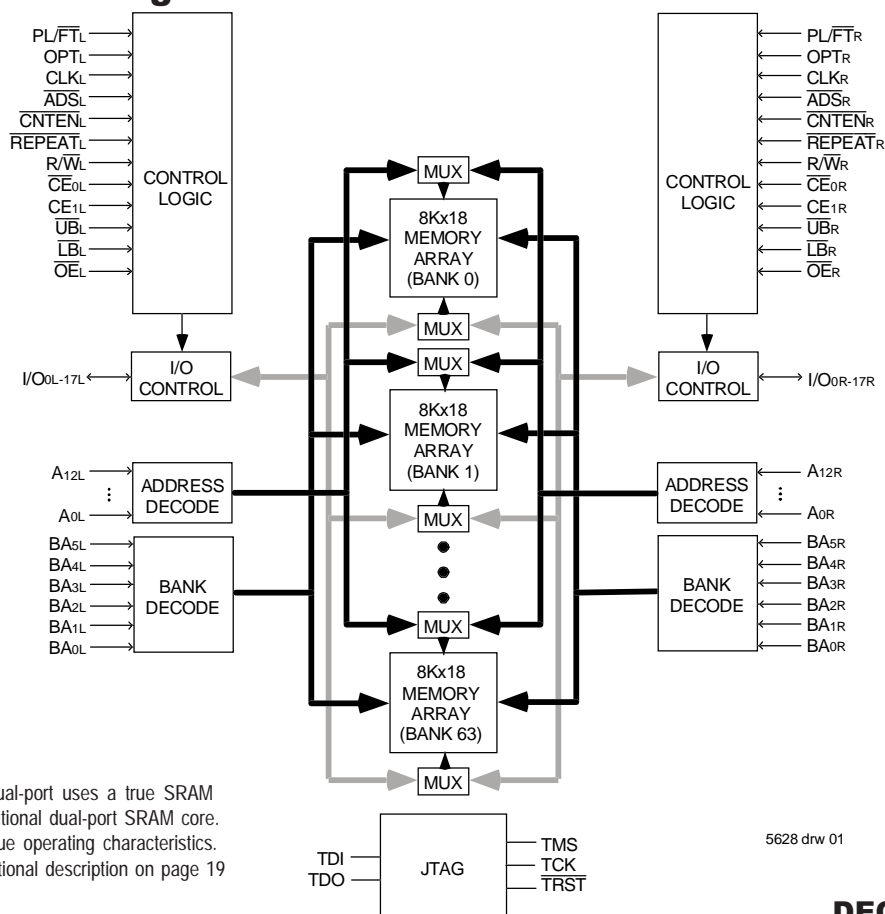

### NOTE:

1. The Bank-Switchable dual-port uses a true SRAM core instead of the traditional dual-port SRAM core. As a result, it has unique operating characteristics. Please refer to the functional description on page 19 for details.

DECEMBER 2002

## Description:

The IDT70V7339 is a high-speed 512Kx18 (9Mbit) synchronous Bank-Switchable Dual-Ported SRAM organized into 64 independent 8Kx18 banks. The device has two independent ports with separate control, address, and I/O pins for each port, allowing each port to access any 8Kx18 memory block not already accessed by the other port. Accesses by the ports into specific banks are controlled via the bank address pins under the user's direct control.

Registers on control, data, and address inputs provide minimal setup and hold times. The timing latitude provided by this approach allows systems to be designed with very short cycle times. With an input data

register, the IDT70V7339 has been optimized for applications having unidirectional or bidirectional data flow in bursts. An automatic power down feature, controlled by CE0 and CE1, permits the on-chip circuitry of each port to enter a very low standby power mode. The dual chip enables also facilitate depth expansion.

The 70V7339 can support an operating voltage of either 3.3V or 2.5V on one or both ports, controllable by the OPT pins. The power supply for the core of the device (VDD) remains at 3.3V. Please refer also to the functional description on page 19.

## Pin Configuration<sup>(1,2,3,4)</sup>

11/20/01

|        |        |        |        |  |       |       |       |      |     |         |         |     |     |       |       |       |       |
|--------|--------|--------|--------|--|-------|-------|-------|------|-----|---------|---------|-----|-----|-------|-------|-------|-------|
| A1     | A2     | A3     | A4     | A5   | A6    | A7    | A8    | A9   | A10 | A11     | A12     | A13 | A14 | A15   | A16   | A17   |       |
| IO9L   | NC     | VSS    | TDO    | NC   | BA3L  | A12L  | A8L   | NC   | VDD | CLKL    | CONTENL | A4L | A0L | OPTL  | NC    | VSS   |       |
| B1     | B2     | B3     | B4     | B5   | B6    | B7    | B8    | B9   | B10 | B11     | B12     | B13 | B14 | B15   | B16   | B17   |       |
| NC     | VSS    | NC     | TDI    | BA4L   | BA0L  | A9L   | NC    | CE0L | VSS | ADSL    | A5L     | A1L | VSS | VDDQR | I/O8L | NC    |       |
| C1     | C2     | C3     | C4     | C5   | C6    | C7    | C8    | C9   | C10 | C11     | C12     | C13 | C14 | C15   | C16   | C17   |       |
| VDDQL  | I/O9R  | VDDQR  | PL/FTL | BA5L   | BA1L  | A10L  | UBL   | CE1L | VSS | RWL     | A6L     | A2L | VDD | I/O8R | NC    | VSS   |       |
| D1     | D2     | D3     | D4     | D5   | D6    | D7    | D8    | D9   | D10 | D11     | D12     | D13 | D14 | D15   | D16   | D17   |       |
| NC     | VSS    | I/O10L | NC     | BA2L   | A11L  | A7L   | LBL   | VDD  | OEL | REPEATL | A3L     | VDD | NC  | VDDQL | I/O7L | I/O7R |       |
| E1     | E2     | E3     | E4     | 70V7339BF<br>BF-208 <sup>(5)</sup><br><br>208-Pin fpBGA<br>Top View <sup>(6)</sup> |       |       |       |      |     |         |         |     |     | E14   | E15   | E16   | E17   |
| I/O11L | NC     | VDDQR  | I/O10R |  |       |       |       |      |     |         |         |     |     | I/O6L | NC    | VSS   | NC    |
| F1     | F2     | F3     | F4     |  |       |       |       |      |     |         |         |     |     | F14   | F15   | F16   | F17   |
| VDDQL  | I/O11R | NC     | VSS    |  |       |       |       |      |     |         |         |     |     | VSS   | I/O6R | NC    | VDDQR |
| G1     | G2     | G3     | G4     |  |       |       |       |      |     |         |         |     |     | G14   | G15   | G16   | G17   |
| NC     | VSS    | I/O12L | NC     |  |       |       |       |      |     |         |         |     |     | NC    | VDDQL | I/O5L | NC    |
| H1     | H2     | H3     | H4     |  |       |       |       |      |     |         |         |     |     | H14   | H15   | H16   | H17   |
| VDD    | NC     | VDDQR  | I/O12R |  |       |       |       |      |     |         |         |     |     | VDD   | NC    | VSS   | I/O5R |
| J1     | J2     | J3     | J4     |  |       |       |       |      |     |         |         |     |     | J14   | J15   | J16   | J17   |
| VDDQL  | VDD    | VSS    | VSS    |  |       |       |       |      |     |         |         |     |     | VSS   | VDD   | VSS   | VDDQR |
| K1     | K2     | K3     | K4     | K14  | K15   | K16   | K17   |      |     |         |         |     |     |       |       |       |       |
| I/O14R | VSS    | I/O13R | VSS    | I/O3R  | VDDQL | I/O4R | VSS   |      |     |         |         |     |     |       |       |       |       |
| L1     | L2     | L3     | L4     | L14  | L15   | L16   | L17   |      |     |         |         |     |     |       |       |       |       |
| NC     | I/O14L | VDDQR  | I/O13L | NC   | I/O3L | VSS   | I/O4L |      |     |         |         |     |     |       |       |       |       |
| M1     | M2     | M3     | M4     | M14  | M15   | M16   | M17   |      |     |         |         |     |     |       |       |       |       |
| VDDQL  | NC     | I/O15R | VSS    | VSS  | NC    | I/O2R | VDDQR |      |     |         |         |     |     |       |       |       |       |
| N1     | N2     | N3     | N4     | N14  | N15   | N16   | N17   |      |     |         |         |     |     |       |       |       |       |
| NC     | VSS    | NC     | I/O15L | I/O1R  | VDDQL | NC    | I/O2L |      |     |         |         |     |     |       |       |       |       |
| P1     | P2     | P3     | P4     | P5   | P6    | P7    | P8    | P9   | P10 | P11     | P12     | P13 | P14 | P15   | P16   | P17   |       |
| I/O16R | I/O16L | VDDQR  | NC     | TRST   | BA3R  | A12R  | A8R   | NC   | VDD | CLKR    | CONTENR | A4R | NC  | I/O1L | VSS   | NC    |       |
| R1     | R2     | R3     | R4     | R5   | R6    | R7    | R8    | R9   | R10 | R11     | R12     | R13 | R14 | R15   | R16   | R17   |       |
| VSS    | NC     | I/O17R | TCK    | BA4R   | BA0R  | A9R   | NC    | CE0R | VSS | ADSR    | A5R     | A1R | VSS | VDDQL | I/O0R | VDDQR |       |
| T1     | T2     | T3     | T4     | T5   | T6    | T7    | T8    | T9   | T10 | T11     | T12     | T13 | T14 | T15   | T16   | T17   |       |
| NC     | I/O17L | VDDQL  | TMS    | BA5R   | BA1R  | A10R  | UBR   | CE1R | VSS | RWR     | A6R     | A2R | VSS | NC    | VSS   | NC    |       |
| U1     | U2     | U3     | U4     | U5   | U6    | U7    | U8    | U9   | U10 | U11     | U12     | U13 | U14 | U15   | U16   | U17   |       |
| VSS    | NC     | PL/FTR | NC     | BA2R   | A11R  | A7R   | LBRL  | VDD  | OER | REPEATR | A3R     | A0R | VDD | OPTR  | NC    | I/O0L |       |

5628 drw 02c

### NOTES:

1. All VDD pins must be connected to 3.3V power supply.
2. All VDDQ pins must be connected to appropriate power supply: 3.3V if OPT pin for that port is set to VIH (3.3V), and 2.5V if OPT pin for that port is set to VIL (0V).
3. All VSS pins must be connected to ground supply.
4. Package body is approximately 15mm x 15mm x 1.4mm with 0.8mm ball pitch.
5. This package code is used to reference the package diagram.
6. This text does not indicate orientation of the actual part-marking.

**Pin Configuration<sup>(1,2,3,4)</sup> (con't.)**

70V7339BC

BC-256<sup>(5)</sup>

256-Pin BGA

Top View<sup>(6)</sup>

11/20/01

|        |        |                          |                            |       |       |       |                         |                          |                          |                             |       |       |       |       |       |
|--------|--------|--------------------------|----------------------------|-------|-------|-------|-------------------------|--------------------------|--------------------------|-----------------------------|-------|-------|-------|-------|-------|
| A1     | A2     | A3                       | A4                         | A5    | A6    | A7    | A8                      | A9                       | A10                      | A11                         | A12   | A13   | A14   | A15   | A16   |
| NC     | TDI    | NC                       | BA4L                       | BA1L  | A11L  | A8L   | NC                      | CE1L                     | $\overline{\text{OEL}}$  | $\overline{\text{CNTENL}}$  | A5L   | A2L   | A0L   | NC    | NC    |
| B1     | B2     | B3                       | B4                         | B5    | B6    | B7    | B8                      | B9                       | B10                      | B11                         | B12   | B13   | B14   | B15   | B16   |
| NC     | NC     | TDO                      | BA5L                       | BA2L  | A12L  | A9L   | $\overline{\text{UBL}}$ | $\overline{\text{CE0L}}$ | $\overline{\text{R/WL}}$ | $\overline{\text{REPEATL}}$ | A4L   | A1L   | VDD   | NC    | NC    |
| C1     | C2     | C3                       | C4                         | C5    | C6    | C7    | C8                      | C9                       | C10                      | C11                         | C12   | C13   | C14   | C15   | C16   |
| NC     | I/O9L  | VSS                      | BA3L                       | BA0L  | A10L  | A7L   | NC                      | $\overline{\text{LBL}}$  | CLKL                     | $\overline{\text{ADSL}}$    | A6L   | A3L   | OPTL  | NC    | I/O8L |
| D1     | D2     | D3                       | D4                         | D5    | D6    | D7    | D8                      | D9                       | D10                      | D11                         | D12   | D13   | D14   | D15   | D16   |
| NC     | I/O9R  | NC                       | $\overline{\text{PL/FTL}}$ | VDDQL | VDDQL | VDDQR | VDDQR                   | VDDQL                    | VDDQL                    | VDDQR                       | VDDQR | VDD   | NC    | NC    | I/O8R |
| E1     | E2     | E3                       | E4                         | E5    | E6    | E7    | E8                      | E9                       | E10                      | E11                         | E12   | E13   | E14   | E15   | E16   |
| I/O10R | I/O10L | NC                       | VDDQL                      | VDD   | VDD   | VSS   | VSS                     | VSS                      | VSS                      | VDD                         | VDD   | VDDQR | NC    | I/O7L | I/O7R |
| F1     | F2     | F3                       | F4                         | F5    | F6    | F7    | F8                      | F9                       | F10                      | F11                         | F12   | F13   | F14   | F15   | F16   |
| I/O11L | NC     | I/O11R                   | VDDQL                      | VDD   | VSS   | VSS   | VSS                     | VSS                      | VSS                      | VSS                         | VDD   | VDDQR | I/O6R | NC    | I/O6L |
| G1     | G2     | G3                       | G4                         | G5    | G6    | G7    | G8                      | G9                       | G10                      | G11                         | G12   | G13   | G14   | G15   | G16   |
| NC     | NC     | I/O12L                   | VDDQR                      | VSS   | VSS   | VSS   | VSS                     | VSS                      | VSS                      | VSS                         | VSS   | VDDQL | I/O5L | NC    | NC    |
| H1     | H2     | H3                       | H4                         | H5    | H6    | H7    | H8                      | H9                       | H10                      | H11                         | H12   | H13   | H14   | H15   | H16   |
| NC     | I/O12R | NC                       | VDDQR                      | VSS   | VSS   | VSS   | VSS                     | VSS                      | VSS                      | VSS                         | VSS   | VDDQL | NC    | NC    | I/O5R |
| J1     | J2     | J3                       | J4                         | J5    | J6    | J7    | J8                      | J9                       | J10                      | J11                         | J12   | J13   | J14   | J15   | J16   |
| I/O13L | I/O14R | I/O13R                   | VDDQL                      | VSS   | VSS   | VSS   | VSS                     | VSS                      | VSS                      | VSS                         | VSS   | VDDQR | I/O4R | I/O3R | I/O4L |
| K1     | K2     | K3                       | K4                         | K5    | K6    | K7    | K8                      | K9                       | K10                      | K11                         | K12   | K13   | K14   | K15   | K16   |
| NC     | NC     | I/O14L                   | VDDQL                      | VSS   | VSS   | VSS   | VSS                     | VSS                      | VSS                      | VSS                         | VSS   | VDDQR | NC    | NC    | I/O3L |
| L1     | L2     | L3                       | L4                         | L5    | L6    | L7    | L8                      | L9                       | L10                      | L11                         | L12   | L13   | L14   | L15   | L16   |
| I/O15L | NC     | I/O15R                   | VDDQR                      | VDD   | VSS   | VSS   | VSS                     | VSS                      | VSS                      | VSS                         | VDD   | VDDQL | I/O2L | NC    | I/O2R |
| M1     | M2     | M3                       | M4                         | M5    | M6    | M7    | M8                      | M9                       | M10                      | M11                         | M12   | M13   | M14   | M15   | M16   |
| I/O16R | I/O16L | NC                       | VDDQR                      | VDD   | VDD   | VSS   | VSS                     | VSS                      | VSS                      | VDD                         | VDD   | VDDQL | I/O1R | I/O1L | NC    |
| N1     | N2     | N3                       | N4                         | N5    | N6    | N7    | N8                      | N9                       | N10                      | N11                         | N12   | N13   | N14   | N15   | N16   |
| NC     | I/O17R | NC                       | $\overline{\text{PL/FTR}}$ | VDDQR | VDDQR | VDDQL | VDDQL                   | VDDQR                    | VDDQR                    | VDDQL                       | VDDQL | VDD   | NC    | I/O0R | NC    |
| P1     | P2     | P3                       | P4                         | P5    | P6    | P7    | P8                      | P9                       | P10                      | P11                         | P12   | P13   | P14   | P15   | P16   |
| NC     | I/O17L | TMS                      | BA3R                       | BA0R  | A10R  | A7R   | NC                      | $\overline{\text{LBR}}$  | CLKR                     | $\overline{\text{ADSR}}$    | A6R   | A3R   | NC    | NC    | I/O0L |
| R1     | R2     | R3                       | R4                         | R5    | R6    | R7    | R8                      | R9                       | R10                      | R11                         | R12   | R13   | R14   | R15   | R16   |
| NC     | NC     | $\overline{\text{TRST}}$ | BA5R                       | BA2R  | A12R  | A9R   | $\overline{\text{UBR}}$ | $\overline{\text{CE0R}}$ | $\overline{\text{R/WR}}$ | $\overline{\text{REPEATR}}$ | A4R   | A1R   | OPTR  | NC    | NC    |
| T1     | T2     | T3                       | T4                         | T5    | T6    | T7    | T8                      | T9                       | T10                      | T11                         | T12   | T13   | T14   | T15   | T16   |
| NC     | TCK    | NC                       | BA4R                       | BA1R  | A11R  | A8R   | NC                      | CE1R                     | $\overline{\text{OER}}$  | $\overline{\text{CNTENR}}$  | A5R   | A2R   | A0R   | NC    | NC    |

5628 drw 02d

**NOTES:**

1. All VDD pins must be connected to 3.3V power supply.
2. All VDDQ pins must be connected to appropriate power supply: 3.3V if OPT pin for that port is set to VIH (3.3V), and 2.5V if OPT pin for that port is set to VIL (0V).
3. All VSS pins must be connected to ground supply.
4. Package body is approximately 17mm x 17mm x 1.4mm, with 1.0mm ball-pitch.
5. This package code is used to reference the package diagram.
6. This text does not indicate orientation of the actual part-marking.

**Pin Configuration<sup>(1,2,3,4,7)</sup> (con't.)**

11/20/01

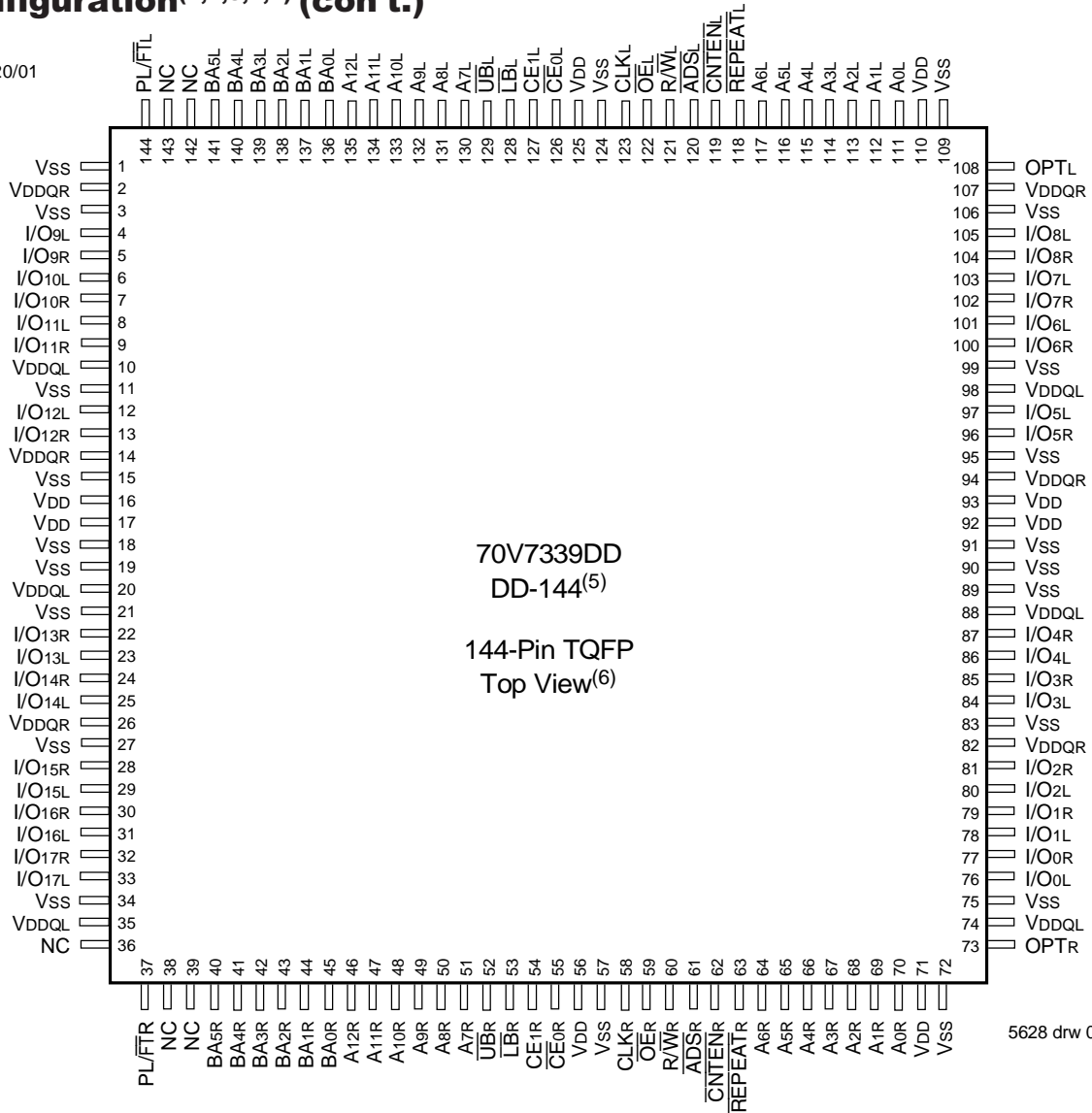

**NOTES:**

1. All V<sub>DD</sub> pins must be connected to 3.3V power supply.
2. All V<sub>DDQ</sub> pins must be connected to appropriate power supply: 3.3V if OPT pin for that port is set to V<sub>IH</sub> (3.3V), and 2.5V if OPT pin for that port is set to V<sub>IL</sub> (0V).
3. All V<sub>SS</sub> pins must be connected to ground supply.
4. Package body is approximately 20mm x 20mm x 1.4mm.
5. This package code is used to reference the package diagram.
6. This text does not indicate orientation of the actual part-marking.
7. Due to the limited pin count, JTAG is not supported in the DD-144 package.

## Pin Names

| Left Port                             | Right Port                            | Names  |
|---------------------------------------|---------------------------------------|--|
| $\overline{CE}_{0L}$ , $CE_{1L}$      | $\overline{CE}_{0R}$ , $CE_{1R}$      | Chip Enables                                     |
| $R/\overline{W}_L$                    | $R/\overline{W}_R$                    | Read/Write Enable                                |
| $\overline{OE}_L$                     | $\overline{OE}_R$                     | Output Enable                                    |
| $BA_{0L}$ - $BA_{5L}$                 | $BA_{0R}$ - $BA_{5R}$                 | Bank Address <sup>(4)</sup>                      |
| $A_{0L}$ - $A_{12L}$                  | $A_{0R}$ - $A_{12R}$                  | Address  |
| $I/O_{0L}$ - $I/O_{17L}$              | $I/O_{0R}$ - $I/O_{17R}$              | Data Input/Output                                |
| $CLK_L$                               | $CLK_R$                               | Clock  |
| $PL/\overline{FT}_L$                  | $PL/\overline{FT}_R$                  | Pipeline/Flow-Through                            |
| $\overline{ADS}_L$                    | $\overline{ADS}_R$                    | Address Strobe Enable                            |
| $\overline{CNTEN}_L$                  | $\overline{CNTEN}_R$                  | Counter Enable                                   |
| $\overline{REPEAT}_L$                 | $\overline{REPEAT}_R$                 | Counter Repeat <sup>(6)</sup>                    |
| $\overline{LB}_L$ , $\overline{UB}_L$ | $\overline{LB}_R$ , $\overline{UB}_R$ | Byte Enables (9-bit bytes)                       |
| $V_{DDQL}$                            | $V_{DDQR}$                            | Power (I/O Bus) (3.3V or 2.5V) <sup>(1)</sup>    |
| $OPT_L$                               | $OPT_R$                               | Option for selecting $V_{DDQX}$ <sup>(1,2)</sup> |
| $V_{DD}$                              |                                       | Power (3.3V) <sup>(1)</sup>                      |
| $V_{SS}$                              |                                       | Ground (0V)                                      |
| $TDI$                                 |                                       | Test Data Input                                  |
| $TDO$                                 |                                       | Test Data Output                                 |
| $TCK$                                 |                                       | Test Logic Clock (10MHz)                         |
| $TMS$                                 |                                       | Test Mode Select                                 |
| $\overline{TRST}$                     |                                       | Reset (Initialize TAP Controller)                |

5628 tbl 01

### NOTES:

- $V_{DD}$ ,  $OPT_x$ , and  $V_{DDQX}$  must be set to appropriate operating levels prior to applying inputs on the I/Os and controls for that port.
- $OPT_x$  selects the operating voltage levels for the I/Os and controls on that port. If  $OPT_x$  is set to VIH (3.3V), then that port's I/Os and controls will operate at 3.3V levels and  $V_{DDQX}$  must be supplied at 3.3V. If  $OPT_x$  is set to VIL (0V), then that port's I/Os and address controls will operate at 2.5V levels and  $V_{DDQX}$  must be supplied at 2.5V. The  $OPT$  pins are independent of one another—both ports can operate at 3.3V levels, both can operate at 2.5V levels, or either can operate at 3.3V with the other at 2.5V.
- When  $\overline{REPEAT}_x$  is asserted, the counter will reset to the last valid address loaded via  $\overline{ADS}_x$ .
- Accesses by the ports into specific banks are controlled by the bank address pins under the user's direct control: each port can access any bank of memory with the shared array that is not currently being accessed by the opposite port (i.e.,  $BA_{0L}$  -  $BA_{5L} \neq BA_{0R}$  -  $BA_{5R}$ ). In the event that both ports try to access the same bank at the same time, neither access will be valid, and data at the two specific addresses targeted by the ports within that bank may be corrupted (in the case that either or both ports are writing) or may result in invalid output (in the case that both ports are trying to read).

**Truth Table I—Read/Write and Enable Control<sup>(1,2,3,4)</sup>**

| $\overline{OE}^3$ | CLK | $\overline{CE}_0$ | CE <sub>1</sub> | $\overline{UB}$ | $\overline{LB}$ | R/ $\overline{W}$ | Upper Byte I/O <sub>9-17</sub> | Lower Byte I/O <sub>0-8</sub> | MODE                     |
|-------------------|-----|-------------------|-----------------|-----------------|-----------------|-------------------|--------------------------------|-------------------------------|--------------------------|
| X                 | ↑   | H                 | X               | X               | X               | X                 | High-Z                         | High-Z                        | Deselected—Power Down    |
| X                 | ↑   | X                 | L               | X               | X               | X                 | High-Z                         | High-Z                        | Deselected—Power Down    |
| X                 | ↑   | L                 | H               | H               | H               | X                 | High-Z                         | High-Z                        | All Bytes Deselected     |
| X                 | ↑   | L                 | H               | H               | L               | L                 | High-Z                         | D <sub>IN</sub>               | Write to Lower Byte Only |
| X                 | ↑   | L                 | H               | L               | H               | L                 | D <sub>IN</sub>                | High-Z                        | Write to Upper Byte Only |
| X                 | ↑   | L                 | H               | L               | L               | L                 | D <sub>IN</sub>                | D <sub>IN</sub>               | Write to both Bytes      |
| L                 | ↑   | L                 | H               | H               | L               | H                 | High-Z                         | D <sub>OUT</sub>              | Read Lower Byte Only     |
| L                 | ↑   | L                 | H               | L               | H               | H                 | D <sub>OUT</sub>               | High-Z                        | Read Upper Byte Only     |
| L                 | ↑   | L                 | H               | L               | L               | H                 | D <sub>OUT</sub>               | D <sub>OUT</sub>              | Read both Bytes          |
| H                 | X   | X                 | X               | X               | X               | X                 | High-Z                         | High-Z                        | Outputs Disabled         |

5628 tbl 02

**NOTES:**

- "H" = V<sub>IH</sub>, "L" = V<sub>IL</sub>, "X" = Don't Care.
- $\overline{ADS}$ ,  $\overline{CNTEN}$ ,  $\overline{REPEAT}$  are set as appropriate for address access. Refer to Truth Table II for details.
- $\overline{OE}$  is an asynchronous input signal.
- It is possible to read or write any combination of bytes during a given access. A few representative samples have been illustrated here.

**Truth Table II—Address and Address Counter Control<sup>(1,2,7)</sup>**

| Address | Previous Address | Addr Used | CLK | $\overline{ADS}$ | $\overline{CNTEN}$ | $\overline{REPEAT}^{(6)}$ | I/O <sup>(3)</sup>    | MODE  |
|---------|------------------|-----------|-----|------------------|--------------------|---------------------------|-----------------------|---|
| An      | X                | An        | ↑   | L <sup>(4)</sup> | X                  | H                         | D <sub>IO</sub> (n)   | External Address Used                                     |
| X       | An               | An + 1    | ↑   | H                | L <sup>(5)</sup>   | H                         | D <sub>IO</sub> (n+1) | Counter Enabled—Internal Address generation               |
| X       | An + 1           | An + 1    | ↑   | H                | H                  | H                         | D <sub>IO</sub> (n+1) | External Address Blocked—Counter disabled (An + 1 reused) |
| X       | X                | An        | ↑   | X                | X                  | L <sup>(4)</sup>          | D <sub>IO</sub> (0)   | Counter Set to last valid $\overline{ADS}$ load           |

5628 tbl 03

**NOTES:**

- "H" = V<sub>IH</sub>, "L" = V<sub>IL</sub>, "X" = Don't Care.
- Read and write operations are controlled by the appropriate setting of R/ $\overline{W}$ ,  $\overline{CE}_0$ , CE<sub>1</sub>,  $\overline{UB}/\overline{LB}$  and  $\overline{OE}$ .
- Outputs configured in flow-through output mode: if outputs are in pipelined mode the data out will be delayed by one cycle.
- $\overline{ADS}$  and  $\overline{REPEAT}$  are independent of all other memory control signals including  $\overline{CE}_0$ , CE<sub>1</sub> and  $\overline{UB}/\overline{LB}$ .
- The address counter advances if  $\overline{CNTEN}$  = V<sub>IL</sub> on the rising edge of CLK, regardless of all other memory control signals including  $\overline{CE}_0$ , CE<sub>1</sub>,  $\overline{UB}/\overline{LB}$ .
- When  $\overline{REPEAT}$  is asserted, the counter will reset to the last valid address loaded via  $\overline{ADS}$ . This value is not set at power-up: a known location should be loaded via  $\overline{ADS}$  during initialization if desired. Any subsequent  $\overline{ADS}$  access during operations will update the  $\overline{REPEAT}$  address location.
- The counter includes bank address and internal address. The counter will advance across bank boundaries. For example, if the counter is in Bank 0, at address FFFh, and is advanced one location, it will move to address 0h in Bank 1. By the same token, the counter at FFFh in Bank 63 will advance to 0h in Bank 0. Refer to Timing Waveform of Counter Repeat, page 18. Care should be taken during operation to avoid having both counters point to the same bank (i.e., ensure BA<sub>0L</sub> - BA<sub>5L</sub> ≠ BA<sub>0R</sub> - BA<sub>5R</sub>), as this condition will invalidate the access for both ports. Please refer to the functional description on page 19 for details.

## Recommended Operating Temperature and Supply Voltage<sup>(1)</sup>

| Grade      | Ambient Temperature | GND | V <sub>DD</sub> |
|------------|---------------------|-----|-----------------|
| Commercial | 0°C to +70°C        | 0V  | 3.3V ± 150mV    |
| Industrial | -40°C to +85°C      | 0V  | 3.3V ± 150mV    |

5628 tbl 04

### NOTE:

- This is the parameter T<sub>A</sub>. This is the "instant on" case temperature.

## Absolute Maximum Ratings<sup>(1)</sup>

| Symbol                           | Rating                               | Commercial & Industrial | Unit |
|----------------------------------|--------------------------------------|-------------------------|------|
| V <sub>TERM</sub> <sup>(2)</sup> | Terminal Voltage with Respect to GND | -0.5 to +4.6            | V    |
| T <sub>BIAS</sub>                | Temperature Under Bias               | -55 to +125             | °C   |
| T <sub>STG</sub>                 | Storage Temperature                  | -65 to +150             | °C   |
| I <sub>OUT</sub>                 | DC Output Current                    | 50                      | mA   |

5628 tbl 06

### NOTES:

- Stresses greater than those listed under ABSOLUTE MAXIMUM RATINGS may cause permanent damage to the device. This is a stress rating only and functional operation of the device at these or any other conditions above those indicated in the operational sections of this specification is not implied. Exposure to absolute maximum rating conditions for extended periods may affect reliability.
- V<sub>TERM</sub> must not exceed V<sub>DD</sub> + 150mV for more than 25% of the cycle time or 4ns maximum, and is limited to ≤ 20mA for the period of V<sub>TERM</sub> ≥ V<sub>DD</sub> + 150mV.

## Recommended DC Operating Conditions with V<sub>DDQ</sub> at 2.5V

| Symbol           | Parameter                                     | Min.                | Typ. | Max.                                    | Unit |
|------------------|---|---------------------|------|---|------|
| V <sub>DD</sub>  | Core Supply Voltage                           | 3.15                | 3.3  | 3.45                                    | V    |
| V <sub>DDQ</sub> | I/O Supply Voltage <sup>(3)</sup>             | 2.4                 | 2.5  | 2.6                                     | V    |
| V <sub>SS</sub>  | Ground  | 0                   | 0    | 0                                       | V    |
| V <sub>IH</sub>  | Input High Voltage (Address & Control Inputs) | 1.7                 | —    | V <sub>DDQ</sub> + 100mV <sup>(2)</sup> | V    |
| V <sub>IH</sub>  | Input High Voltage - I/O <sup>(3)</sup>       | 1.7                 | —    | V <sub>DDQ</sub> + 100mV <sup>(2)</sup> | V    |
| V <sub>IL</sub>  | Input Low Voltage                             | -0.3 <sup>(1)</sup> | —    | 0.7                                     | V    |

5628 tbl 05a

### NOTES:

- Undershoot of V<sub>IL</sub> ≥ -1.5V for pulse width less than 10ns is allowed.
- V<sub>TERM</sub> must not exceed V<sub>DDQ</sub> + 100mV.
- To select operation at 2.5V levels on the I/Os and controls of a given port, the OPT pin for that port must be set to V<sub>IL</sub> (0V), and V<sub>DDQX</sub> for that port must be supplied as indicated above.

## Recommended DC Operating Conditions with V<sub>DDQ</sub> at 3.3V

| Symbol           | Parameter  | Min.                | Typ. | Max.                                    | Unit |
|------------------|--|---------------------|------|---|------|
| V <sub>DD</sub>  | Core Supply Voltage  | 3.15                | 3.3  | 3.45                                    | V    |
| V <sub>DDQ</sub> | I/O Supply Voltage <sup>(3)</sup>                            | 3.15                | 3.3  | 3.45                                    | V    |
| V <sub>SS</sub>  | Ground   | 0                   | 0    | 0                                       | V    |
| V <sub>IH</sub>  | Input High Voltage (Address & Control Inputs) <sup>(3)</sup> | 2.0                 | —    | V <sub>DDQ</sub> + 150mV <sup>(2)</sup> | V    |
| V <sub>IH</sub>  | Input High Voltage - I/O <sup>(3)</sup>                      | 2.0                 | —    | V <sub>DDQ</sub> + 150mV <sup>(2)</sup> | V    |
| V <sub>IL</sub>  | Input Low Voltage  | -0.3 <sup>(1)</sup> | —    | 0.8                                     | V    |

5628 tbl 05b

### NOTES:

- Undershoot of V<sub>IL</sub> ≥ -1.5V for pulse width less than 10ns is allowed.
- V<sub>TERM</sub> must not exceed V<sub>DDQ</sub> + 150mV.
- To select operation at 3.3V levels on the I/Os and controls of a given port, the OPT pin for that port must be set to V<sub>IH</sub> (3.3V), and V<sub>DDQX</sub> for that port must be supplied as indicated above.

**Capacitance<sup>(1)</sup>****(TA = +25°C, F = 1.0MHz) PQFP ONLY**

| Symbol                          | Parameter          | Conditions <sup>(2)</sup> | Max. | Unit |
|---------------------------------|--------------------|---------------------------|------|------|
| C <sub>IN</sub>                 | Input Capacitance  | V <sub>IN</sub> = 3dV     | 8    | pF   |
| C <sub>OUT</sub> <sup>(3)</sup> | Output Capacitance | V <sub>OUT</sub> = 3dV    | 10.5 | pF   |

5628 tbl 07

**NOTES:**

- These parameters are determined by device characterization, but are not production tested.
- 3dV references the interpolated capacitance when the input and output switch from 0V to 3V or from 3V to 0V.
- C<sub>OUT</sub> also references C<sub>IO</sub>.

**DC Electrical Characteristics Over the Operating Temperature and Supply Voltage Range (V<sub>DD</sub> = 3.3V ± 150mV)**

| Symbol                 | Parameter                             | Test Conditions   | 70V7339S |      | Unit |
|------------------------|---------------------------------------|---|----------|------|------|
|                        |                                       |   | Min.     | Max. |      |
| I <sub>L</sub>         | Input Leakage Current <sup>(1)</sup>  | V <sub>DDQ</sub> = Max., V <sub>IN</sub> = 0V to V <sub>DDQ</sub>                   | —        | 10   | μA   |
| I <sub>O</sub>         | Output Leakage Current <sup>(1)</sup> | $\overline{CE}_0 = V_H$ or $CE_1 = V_L$ , V <sub>OUT</sub> = 0V to V <sub>DDQ</sub> | —        | 10   | μA   |
| V <sub>OL</sub> (3.3V) | Output Low Voltage <sup>(2)</sup>     | I <sub>OL</sub> = +4mA, V <sub>DDQ</sub> = Min.                                     | —        | 0.4  | V    |
| V <sub>OH</sub> (3.3V) | Output High Voltage <sup>(2)</sup>    | I <sub>OH</sub> = -4mA, V <sub>DDQ</sub> = Min.                                     | 2.4      | —    | V    |
| V <sub>OL</sub> (2.5V) | Output Low Voltage <sup>(2)</sup>     | I <sub>OL</sub> = +2mA, V <sub>DDQ</sub> = Min.                                     | —        | 0.4  | V    |
| V <sub>OH</sub> (2.5V) | Output High Voltage <sup>(2)</sup>    | I <sub>OH</sub> = -2mA, V <sub>DDQ</sub> = Min.                                     | 2.0      | —    | V    |

5628 tbl 08

**NOTES:**

- At V<sub>DD</sub> ≤ 2.0V leakages are undefined.
- V<sub>DDQ</sub> is selectable (3.3V/2.5V) via OPT pins. Refer to p.5 for details.

## DC Electrical Characteristics Over the Operating Temperature and Supply Voltage Range<sup>(5)</sup> ( $V_{DD} = 3.3V \pm 150mV$ )

| Symbol | Parameter   | Test Condition  | Version | 70V7339S200 <sup>(7)</sup><br>Com'l Only |      | 70V7339S166 <sup>(6)</sup><br>Com'l & Ind |      | 70V7339S133<br>Com'l & Ind |      | Unit |
|--------|---|---|---------|--|------|---|------|----------------------------|------|------|
|        |   |   |         | Typ. <sup>(4)</sup>                      | Max. | Typ. <sup>(4)</sup>                       | Max. | Typ. <sup>(4)</sup>        | Max. |      |
| IDD    | Dynamic Operating Current (Both Ports Active)         | $\overline{CE}_L$ and $\overline{CE}_R = V_{IL}$ ,<br>Outputs Disabled,<br>$f = f_{MAX}^{(1)}$  | COM'L S | 815                                      | 950  | 675                                       | 790  | 550                        | 645  | mA   |
|        |   |   | IND S   | —  | —    | 675                                       | 830  | 550                        | 675  |      |
| ISB1   | Standby Current (Both Ports - TTL Level Inputs)       | $\overline{CE}_L = \overline{CE}_R = V_{IH}$<br>$f = f_{MAX}^{(1)}$   | COM'L S | 340                                      | 410  | 275                                       | 340  | 250                        | 295  | mA   |
|        |   |   | IND S   | —  | —    | 275                                       | 355  | 250                        | 310  |      |
| ISB2   | Standby Current (One Port - TTL Level Inputs)         | $\overline{CE}_{A^*} = V_{IL}$ and $\overline{CE}_{B^*} = V_{IH}^{(3)}$<br>Active Port Outputs Disabled,<br>$f = f_{MAX}^{(1)}$   | COM'L S | 690                                      | 770  | 515                                       | 640  | 460                        | 520  | mA   |
|        |   |   | IND S   | —  | —    | 515                                       | 660  | 460                        | 545  |      |
| ISB3   | Full Standby Current (Both Ports - CMOS Level Inputs) | Both Ports $\overline{CE}_L$ and $\overline{CE}_R \geq V_{DD} - 0.2V$ , $V_{IN} \geq V_{DD} - 0.2V$<br>or $V_{IN} \leq 0.2V$ , $f = 0^{(2)}$  | COM'L S | 10                                       | 30   | 10  | 30   | 10                         | 30   | mA   |
|        |   |   | IND S   | —  | —    | 10  | 40   | 10                         | 40   |      |
| ISB4   | Full Standby Current (One Port - CMOS Level Inputs)   | $\overline{CE}_{A^*} \leq 0.2V$ and $\overline{CE}_{B^*} \geq V_{DD} - 0.2V^{(3)}$<br>$V_{IN} \geq V_{DD} - 0.2V$ or $V_{IN} \leq 0.2V$<br>Active Port, Outputs Disabled, $f = f_{MAX}^{(1)}$ | COM'L S | 690                                      | 770  | 515                                       | 640  | 460                        | 520  | mA   |
|        |   |   | IND S   | —  | —    | 515                                       | 660  | 460                        | 545  |      |

5628 tbl 09

### NOTES:

- At  $f = f_{MAX}$ , address and control lines (except Output Enable) are cycling at the maximum frequency clock cycle of  $1/t_{cyc}$ , using "AC TEST CONDITIONS" at input levels of GND to 3V.
- $f = 0$  means no address, clock, or control lines change. Applies only to input at CMOS level standby.
- Port "A" may be either left or right port. Port "B" is the opposite from port "A".
- $V_{DD} = 3.3V$ ,  $T_A = 25^\circ C$  for Typ, and are not production tested.  $I_{DD} dc(f=0) = 120mA$  (Typ).
- $\overline{CE}_X = V_{IL}$  means  $\overline{CE}_{0X} = V_{IL}$  and  $CE_{1X} = V_{IH}$   
 $\overline{CE}_X = V_{IH}$  means  $\overline{CE}_{0X} = V_{IH}$  or  $CE_{1X} = V_{IL}$   
 $\overline{CE}_X \leq 0.2V$  means  $\overline{CE}_{0X} \leq 0.2V$  and  $CE_{1X} \geq V_{CC} - 0.2V$   
 $\overline{CE}_X \geq V_{CC} - 0.2V$  means  $\overline{CE}_{0X} \geq V_{CC} - 0.2V$  or  $CE_{1X} \leq 0.2V$   
"X" represents "L" for left port or "R" for right port.
- 166MHz Industrial Temperature not available in BF-208 package.
- This speed grade available when  $V_{DD0} = 3.3V$  for a specific port (i.e.,  $OPTx = V_{IH}$ ). This speed grade is available in BC-256 only.

**AC Test Conditions (V<sub>DDQ</sub> - 3.3V/2.5V)**

|   |                         |
|---|-------------------------|
| Input Pulse Levels (Address & Controls) | GND to 3.0V/GND to 2.4V |
| Input Pulse Levels (I/Os)               | GND to 3.0V/GND to 2.4V |
| Input Rise/Fall Times                   | 2ns                     |
| Input Timing Reference Levels           | 1.5V/1.25V              |
| Output Reference Levels                 | 1.5V/1.25V              |
| Output Load                             | Figures 1 and 2         |

5628 tbl 10

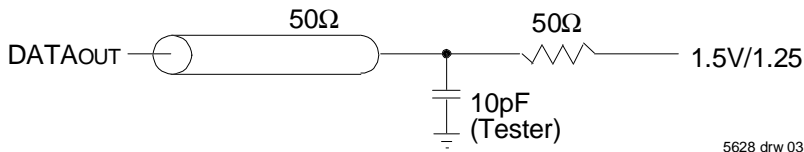

Figure 1. AC Output Test load.

5628 drw 03

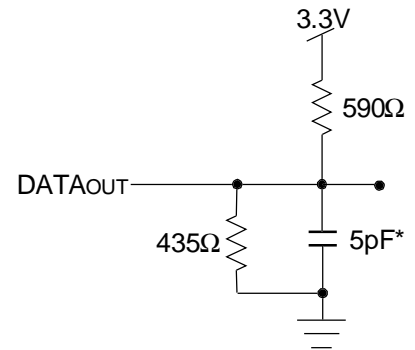
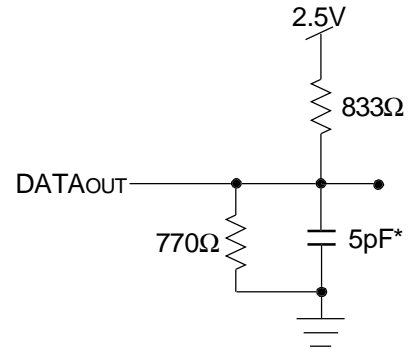
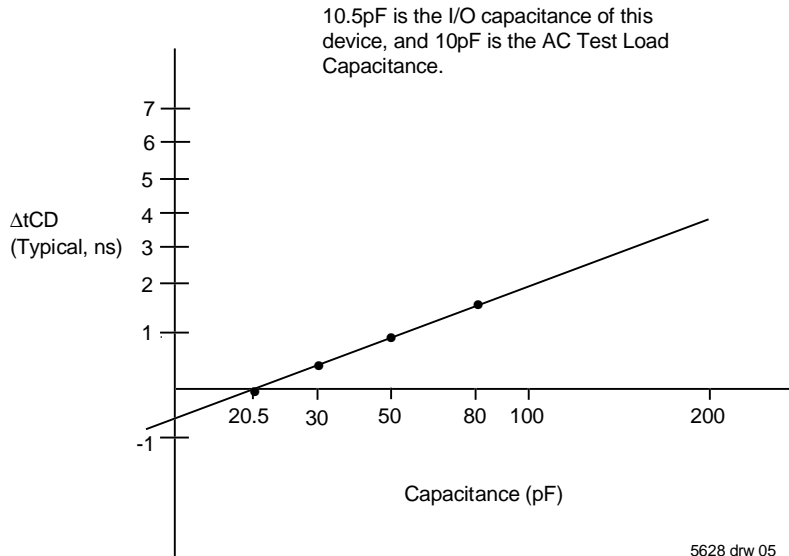

Figure 2. Output Test Load  
(For t<sub>CKLZ</sub>, t<sub>CKHZ</sub>, t<sub>OLZ</sub>, and t<sub>OHZ</sub>).  
\*Including scope and jig.

5628 drw 04



5628 drw 05

Figure 3. Typical Output Derating (Lumped Capacitive Load).

## AC Electrical Characteristics Over the Operating Temperature Range (Read and Write Cycle Timing)<sup>(2,3)</sup> ( $V_{DD} = 3.3V \pm 150mV$ , $T_A = 0^\circ C$ to $+70^\circ C$ )

| Symbol                    | Parameter   | 70V7339S200 <sup>(6)</sup><br>Com'l Only |      | 70V7339S166 <sup>(3,4)</sup><br>Com'l & Ind |      | 70V7339S133 <sup>(3)</sup><br>Com'l & Ind |      | Unit |
|---------------------------|---|--|------|---|------|---|------|------|
|                           |   | Min.                                     | Max. | Min.  | Max. | Min.                                      | Max. |      |
| t <sub>CYC1</sub>         | Clock Cycle Time (Flow-Through) <sup>(1)</sup>    | 15                                       | ---  | 20  | ---  | 25  | ---  | ns   |
| t <sub>CYC2</sub>         | Clock Cycle Time (Pipelined) <sup>(1)</sup>       | 5  | ---  | 6   | ---  | 7.5                                       | ---  | ns   |
| t <sub>CH1</sub>          | Clock High Time (Flow-Through) <sup>(1)</sup>     | 5  | ---  | 6   | ---  | 7   | ---  | ns   |
| t <sub>CL1</sub>          | Clock Low Time (Flow-Through) <sup>(1)</sup>      | 5  | ---  | 6   | ---  | 7   | ---  | ns   |
| t <sub>CH2</sub>          | Clock High Time (Pipelined) <sup>(2)</sup>        | 2.0                                      | ---  | 2.1   | ---  | 2.6                                       | ---  | ns   |
| t <sub>CL2</sub>          | Clock Low Time (Pipelined) <sup>(1)</sup>         | 2.0                                      | ---  | 2.1   | ---  | 2.6                                       | ---  | ns   |
| t <sub>r</sub>            | Clock Rise Time                                   | ---                                      | 1.5  | ---   | 1.5  | ---                                       | 1.5  | ns   |
| t <sub>f</sub>            | Clock Fall Time                                   | ---                                      | 1.5  | ---   | 1.5  | ---                                       | 1.5  | ns   |
| t <sub>SA</sub>           | Address Setup Time                                | 1.5                                      | ---  | 1.7   | ---  | 1.8                                       | ---  | ns   |
| t <sub>HA</sub>           | Address Hold Time                                 | 0.5                                      | ---  | 0.5   | ---  | 0.5                                       | ---  | ns   |
| t <sub>SC</sub>           | Chip Enable Setup Time                            | 1.5                                      | ---  | 1.7   | ---  | 1.8                                       | ---  | ns   |
| t <sub>HC</sub>           | Chip Enable Hold Time                             | 0.5                                      | ---  | 0.5   | ---  | 0.5                                       | ---  | ns   |
| t <sub>SW</sub>           | R/W Setup Time                                    | 1.5                                      | ---  | 1.7   | ---  | 1.8                                       | ---  | ns   |
| t <sub>HW</sub>           | R/W Hold Time                                     | 0.5                                      | ---  | 0.5   | ---  | 0.5                                       | ---  | ns   |
| t <sub>SD</sub>           | Input Data Setup Time                             | 1.5                                      | ---  | 1.7   | ---  | 1.8                                       | ---  | ns   |
| t <sub>HD</sub>           | Input Data Hold Time                              | 0.5                                      | ---  | 0.5   | ---  | 0.5                                       | ---  | ns   |
| t <sub>SAD</sub>          | $\overline{ADS}$ Setup Time                       | 1.5                                      | ---  | 1.7   | ---  | 1.8                                       | ---  | ns   |
| t <sub>HAD</sub>          | $\overline{ADS}$ Hold Time                        | 0.5                                      | ---  | 0.5   | ---  | 0.5                                       | ---  | ns   |
| t <sub>SCN</sub>          | $\overline{CNTEN}$ Setup Time                     | 1.5                                      | ---  | 1.7   | ---  | 1.8                                       | ---  | ns   |
| t <sub>HCN</sub>          | $\overline{CNTEN}$ Hold Time                      | 0.5                                      | ---  | 0.5   | ---  | 0.5                                       | ---  | ns   |
| t <sub>SRPT</sub>         | $\overline{REPEAT}$ Setup Time                    | 1.5                                      | ---  | 1.7   | ---  | 1.8                                       | ---  | ns   |
| t <sub>HRT</sub>          | $\overline{REPEAT}$ Hold Time                     | 0.5                                      | ---  | 0.5   | ---  | 0.5                                       | ---  | ns   |
| t <sub>OE</sub>           | Output Enable to Data Valid                       | ---                                      | 4.0  | ---   | 4.0  | ---                                       | 4.2  | ns   |
| t <sub>OLZ</sub>          | Output Enable to Output Low-Z                     | 0.5                                      | ---  | 0.5   | ---  | 0.5                                       | ---  | ns   |
| t <sub>OHZ</sub>          | Output Enable to Output High-Z                    | 1  | 3.4  | 1   | 3.6  | 1   | 4.2  | ns   |
| t <sub>CD1</sub>          | Clock to Data Valid (Flow-Through) <sup>(1)</sup> | ---                                      | 10   | ---   | 12   | ---                                       | 15   | ns   |
| t <sub>CD2</sub>          | Clock to Data Valid (Pipelined) <sup>(1)</sup>    | ---                                      | 3.4  | ---   | 3.6  | ---                                       | 4.2  | ns   |
| t <sub>DC</sub>           | Data Output Hold After Clock High                 | 1  | ---  | 1   | ---  | 1   | ---  | ns   |
| t <sub>CKHZ</sub>         | Clock High to Output High-Z                       | 1  | 3.4  | 1   | 3.6  | 1   | 4.2  | ns   |
| t <sub>CKLZ</sub>         | Clock High to Output Low-Z                        | 0.5                                      | ---  | 0.5   | ---  | 0.5                                       | ---  | ns   |
| <b>Port-to-Port Delay</b> |   |  |      |   |      |   |      |      |
| t <sub>CO</sub>           | Clock-to-Clock Offset                             | 5.0                                      | ---  | 6.0   | ---  | 7.5                                       | ---  | ns   |

**NOTES:**

5628 tbl 11

- The Pipelined output parameters (t<sub>CYC2</sub>, t<sub>CD2</sub>) apply to either or both left and right ports when  $\overline{FT}/PIPEX = V_{IH}$ . Flow-through parameters (t<sub>CYC1</sub>, t<sub>CD1</sub>) apply when  $\overline{FT}/PIPEX = V_{IL}$  for that port.
- All input signals are synchronous with respect to the clock except for the asynchronous Output Enable ( $\overline{OE}$ ) and  $\overline{FT}/PIPEX$ .  $\overline{FT}/PIPEX$  should be treated as a DC signal, i.e. steady state during operation.
- These values are valid for either level of  $V_{DD0}$  (3.3V/2.5V). See page 5 for details on selecting the desired operating voltage levels for each port.
- 166MHz Industrial Temperature not available in BF-208 package.
- This speed grade available when  $V_{DD0} = 3.3V$  for a specific port (i.e.,  $OPTx = V_{IH}$ ). This speed grade available in BC-256 package only.

## Timing Waveform of Read Cycle for Pipelined Operation (ADS Operation) (FT/PIPE"x" = VIH)<sup>(2)</sup>

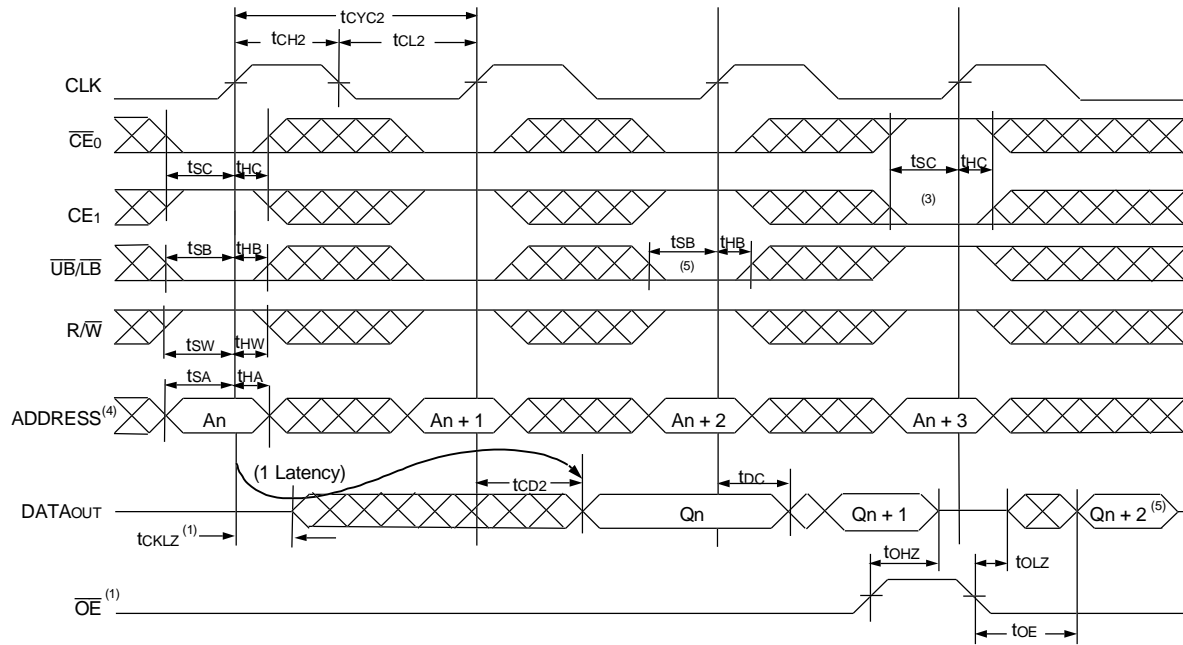

5628 drw 06

## Timing Waveform of Read Cycle for Flow-through Output (FT/PIPE"x" = VIL)<sup>(2,6)</sup>

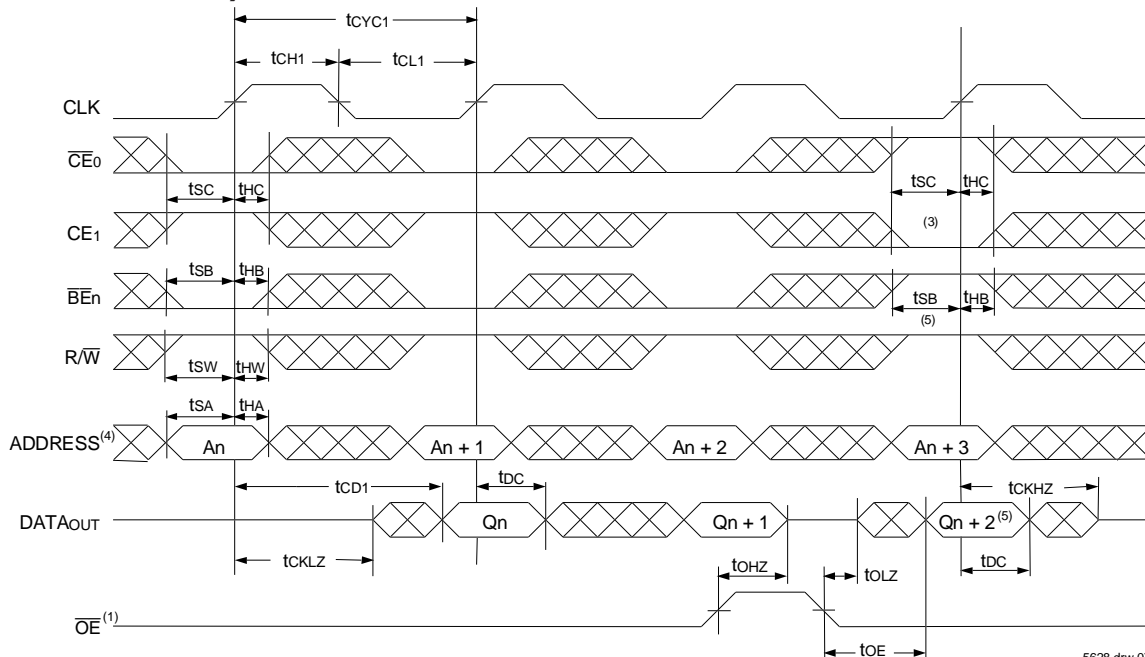

5628 drw 07

### NOTES:

1.  $\overline{OE}$  is asynchronously controlled; all other inputs are synchronous to the rising clock edge.
2. ADS = VIL, CNTEN and REPEAT = VIH.
3. The output is disabled (High-Impedance state) by  $\overline{CE0} = \text{VIH}$ ,  $\text{CE1} = \text{VIL}$ ,  $\overline{UB/LB} = \text{VIH}$  following the next rising edge of the clock. Refer to Truth Table 1.
4. Addresses do not have to be accessed sequentially since  $\overline{ADS} = \text{VIL}$  constantly loads the address on the rising edge of the CLK; numbers are for reference use only.
5. If  $\overline{UB/LB}$  was HIGH, then the appropriate Byte of DATAout for  $Qn + 2$  would be disabled (High-Impedance state).
6. "x" denotes Left or Right port. The diagram is with respect to that port.

### Timing Waveform of a Multi-Device Pipelined Read<sup>(1,2)</sup>

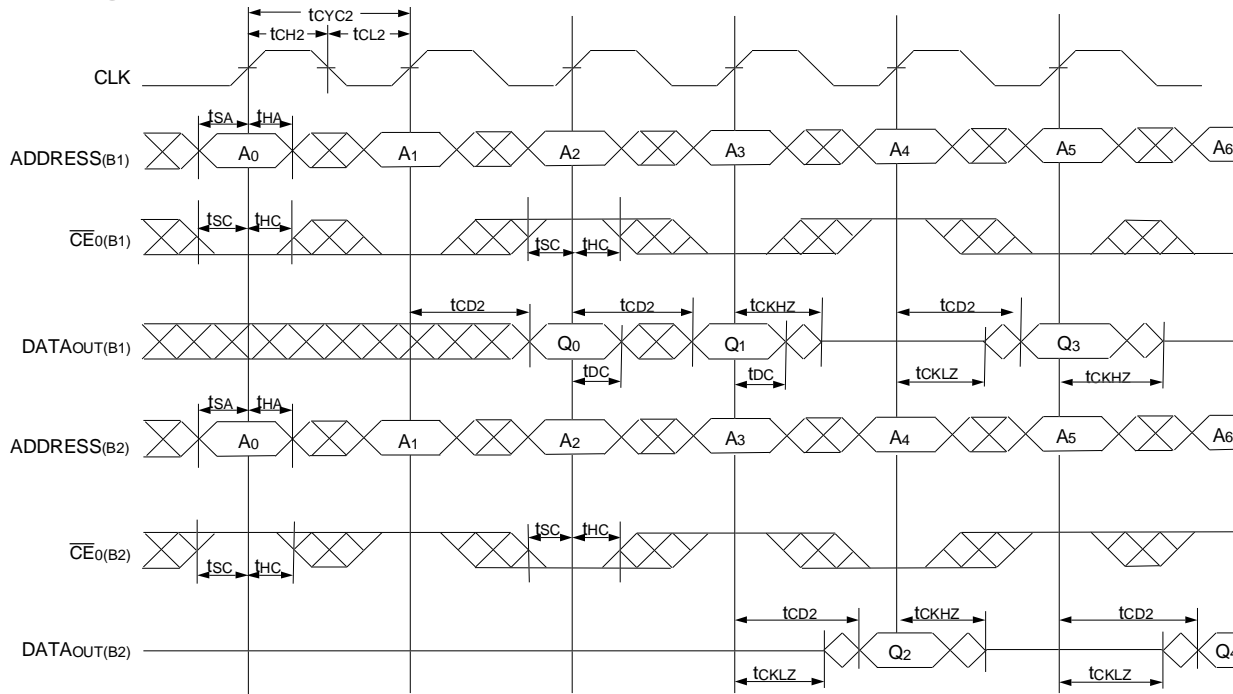

5628 drw 08

### Timing Waveform of a Multi-Device Flow-Through Read<sup>(1,2)</sup>

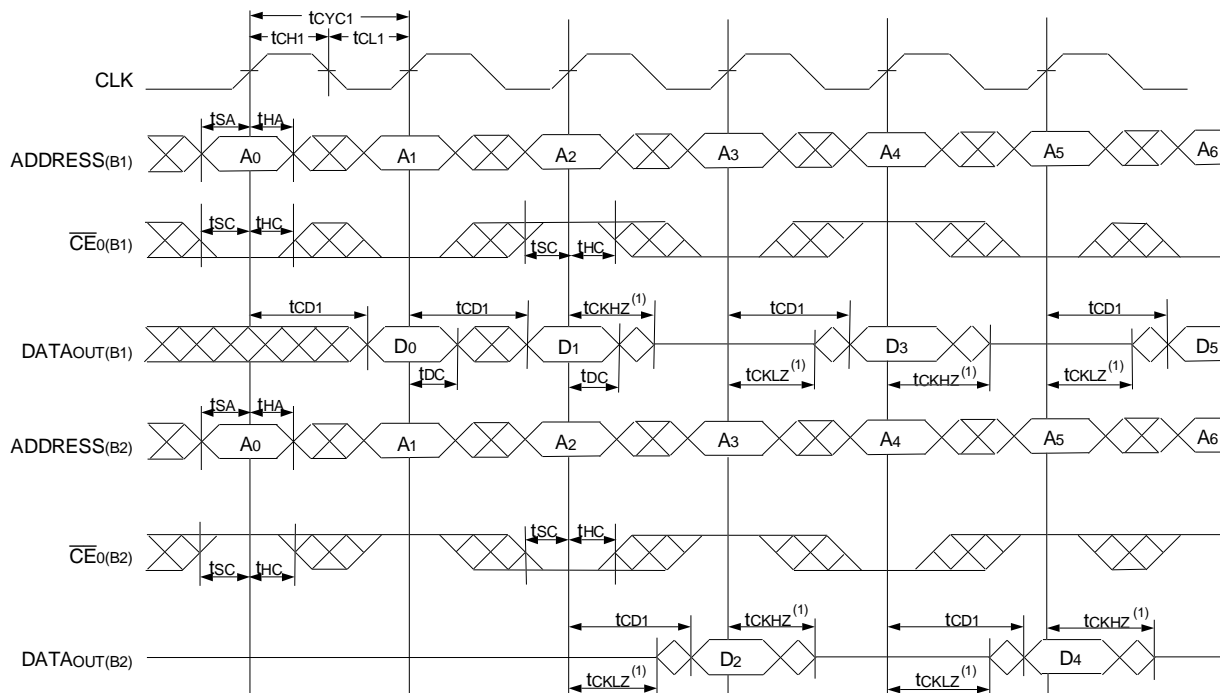

5628 drw 09

**NOTES:**

1. B1 Represents Device #1; B2 Represents Device #2. Each Device consists of one IDT70V7339 for this waveform, and are setup for depth expansion in this example. ADDRESS(B1) = ADDRESS(B2) in this situation.
2.  $\overline{UB/LB}$ ,  $\overline{OE}$ , and  $\overline{ADS} = V_{IL}$ ;  $\overline{CE1(B1)}$ ,  $\overline{CE1(B2)}$ ,  $R/W$ ,  $\overline{CNTEN}$ , and  $\overline{REPEAT} = V_{IH}$ .

### Timing Waveform of Port A Write to Pipelined Port B Read<sup>(1,2,4)</sup>

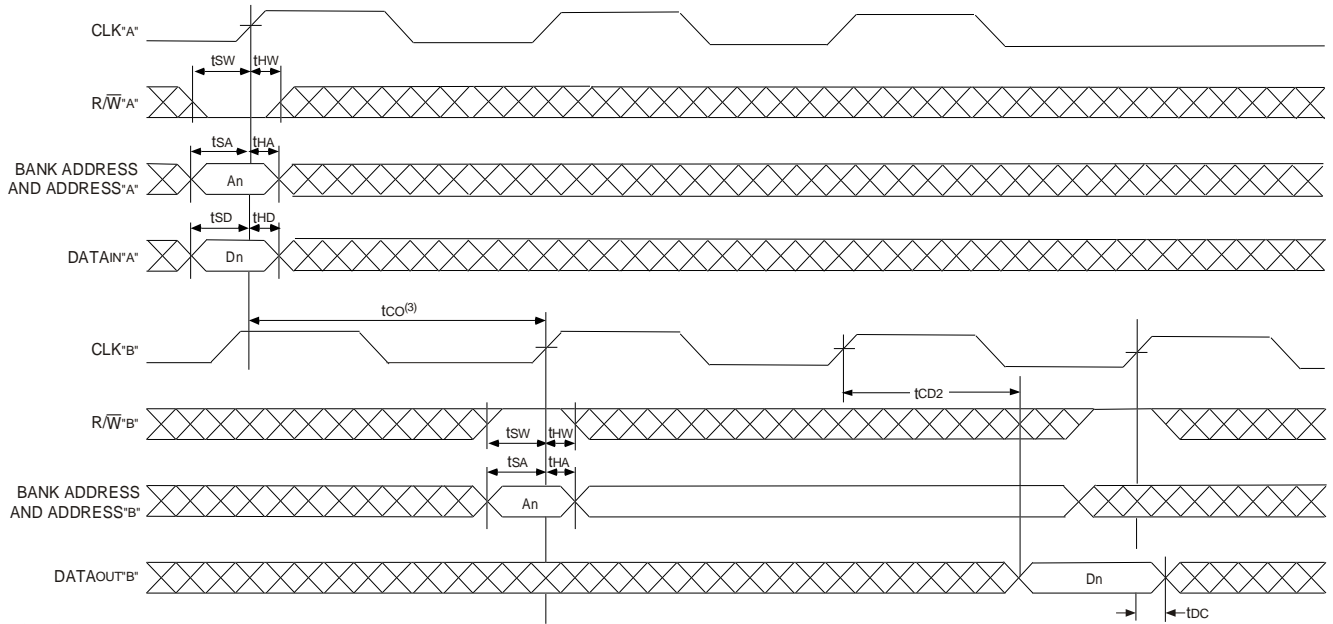

**NOTES:**

1.  $\overline{CE}_0$ ,  $\overline{BEn}$ , and  $\overline{ADS} = V_{IL}$ ;  $\overline{CE}_1$ ,  $\overline{CNTEN}$ , and  $\overline{REPEAT} = V_{IH}$ .
2.  $\overline{OE} = V_{IL}$  for the Right Port, which is being read from.  $\overline{OE} = V_{IH}$  for the Left Port, which is being written to.
3. If  $t_{co} <$  minimum specified, then operations from both ports are INVALID. If  $t_{co} \geq$  minimum, then data from Port "B" read is available on first Port "B" clock cycle (ie, time from write to valid read on opposite port will be  $t_{co} + t_{cyc2} + t_{cd2}$ ).
4. All timing is the same for both left and right ports. Port "A" may be either left or right port. Port "B" is the opposite of Port "A".

5628 drw 10

### Timing Waveform with Port-to-Port Flow-Through Read<sup>(1,2,4)</sup>

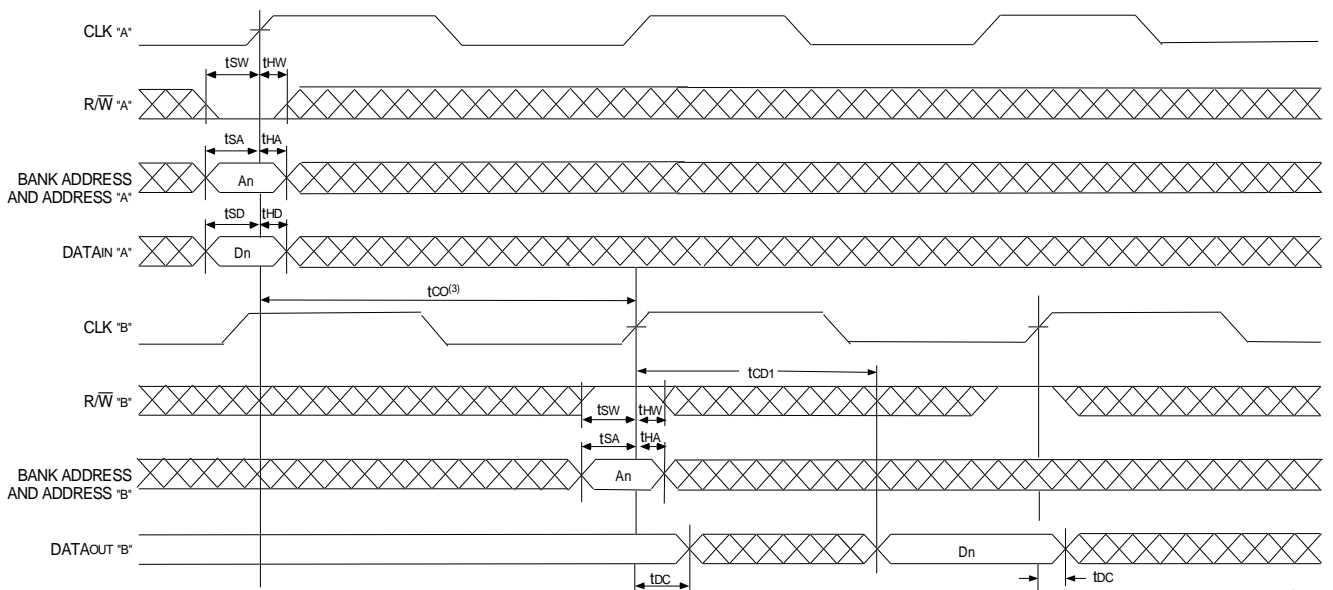

**NOTES:**

1.  $\overline{CE}_0$ ,  $\overline{BEn}$ , and  $\overline{ADS} = V_{IL}$ ;  $\overline{CE}_1$ ,  $\overline{CNTEN}$ , and  $\overline{REPEAT} = V_{IH}$ .
2.  $\overline{OE} = V_{IL}$  for the Right Port, which is being read from.  $\overline{OE} = V_{IH}$  for the Left Port, which is being written to.
3. If  $t_{co} <$  minimum specified, then operations from both ports are INVALID. If  $t_{co} \geq$  minimum, then data from Port "B" read is available on first Port "B" clock cycle (i.e., time from write to valid read on opposite port will be  $t_{co} + t_{cd1}$ ).
4. All timing is the same for both left and right ports. Port "A" may be either left or right port. Port "B" is the opposite of Port "A".

5628 drw 11

### Timing Waveform of Pipelined Read-to-Write-to-Read ( $\overline{OE} = V_{IL}$ )<sup>(2)</sup>

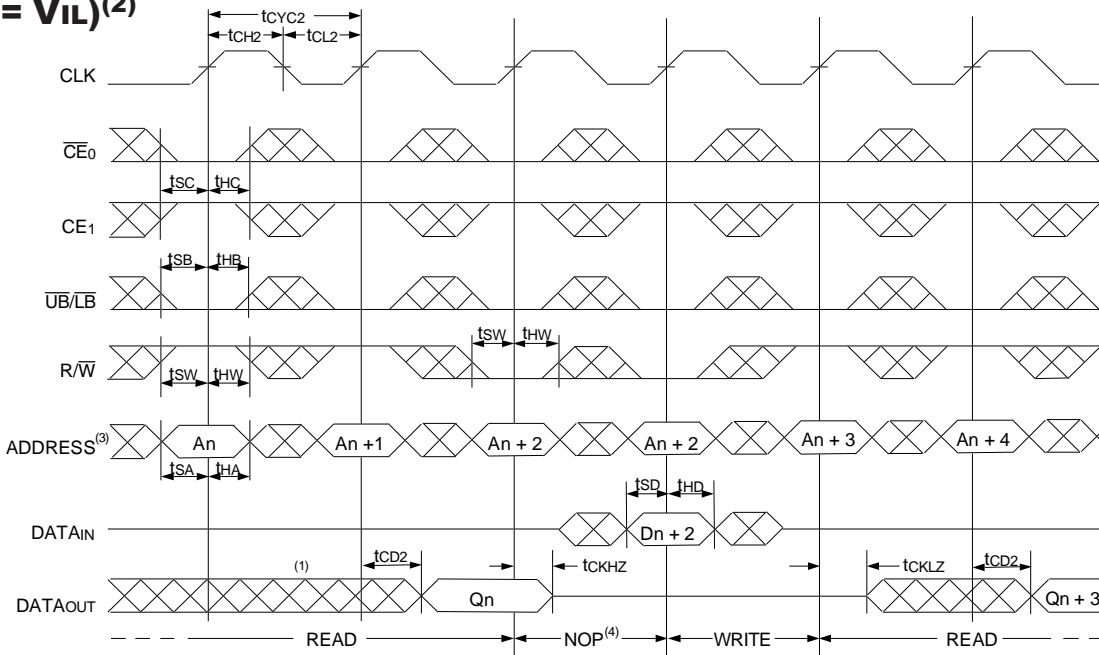

5628 drw 12

**NOTES:**

1. Output state (High, Low, or High-impedance) is determined by the previous cycle control signals.
2.  $\overline{CE}_0$ ,  $\overline{BE}_n$ , and  $\overline{ADS} = V_{IL}$ ;  $CE_1$ ,  $CNTEN$ , and  $REPEAT = V_{IH}$ . "NOP" is "No Operation".
3. Addresses do not have to be accessed sequentially since  $\overline{ADS} = V_{IL}$  constantly loads the address on the rising edge of the CLK; numbers are for reference use only.
4. "NOP" is "No Operation." Data in memory at the selected address may be corrupted and should be re-written to guarantee data integrity.

### Timing Waveform of Pipelined Read-to-Write-to-Read ( $\overline{OE}$ Controlled)<sup>(2)</sup>

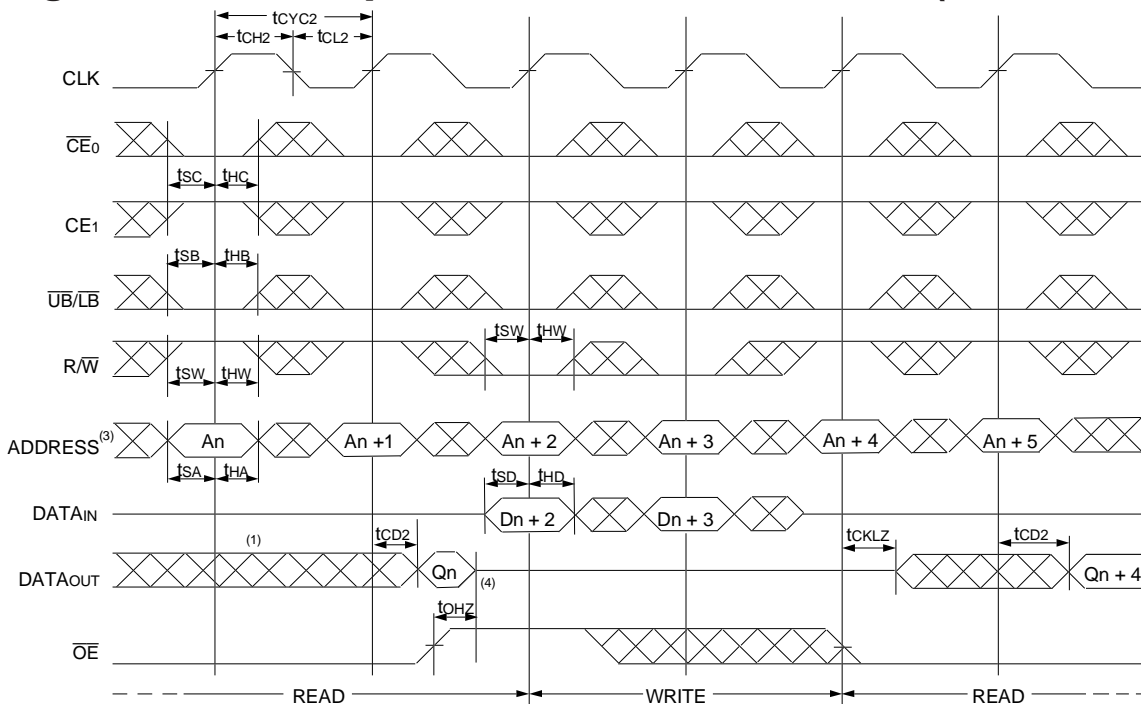

5628 drw 13

**NOTES:**

1. Output state (High, Low, or High-impedance) is determined by the previous cycle control signals.
2.  $\overline{CE}_0$ ,  $\overline{UB/LB}$ , and  $\overline{ADS} = V_{IL}$ ;  $CE_1$ ,  $CNTEN$ , and  $REPEAT = V_{IH}$ .
3. Addresses do not have to be accessed sequentially since  $\overline{ADS} = V_{IL}$  constantly loads the address on the rising edge of the CLK; numbers are for reference use only.
4. This timing does not meet requirements for fastest speed grade. This waveform indicates how logically it could be done if timing so allows.

### Timing Waveform of Flow-Through Read-to-Write-to-Read ( $\overline{OE} = V_{IL}$ )<sup>(2)</sup>

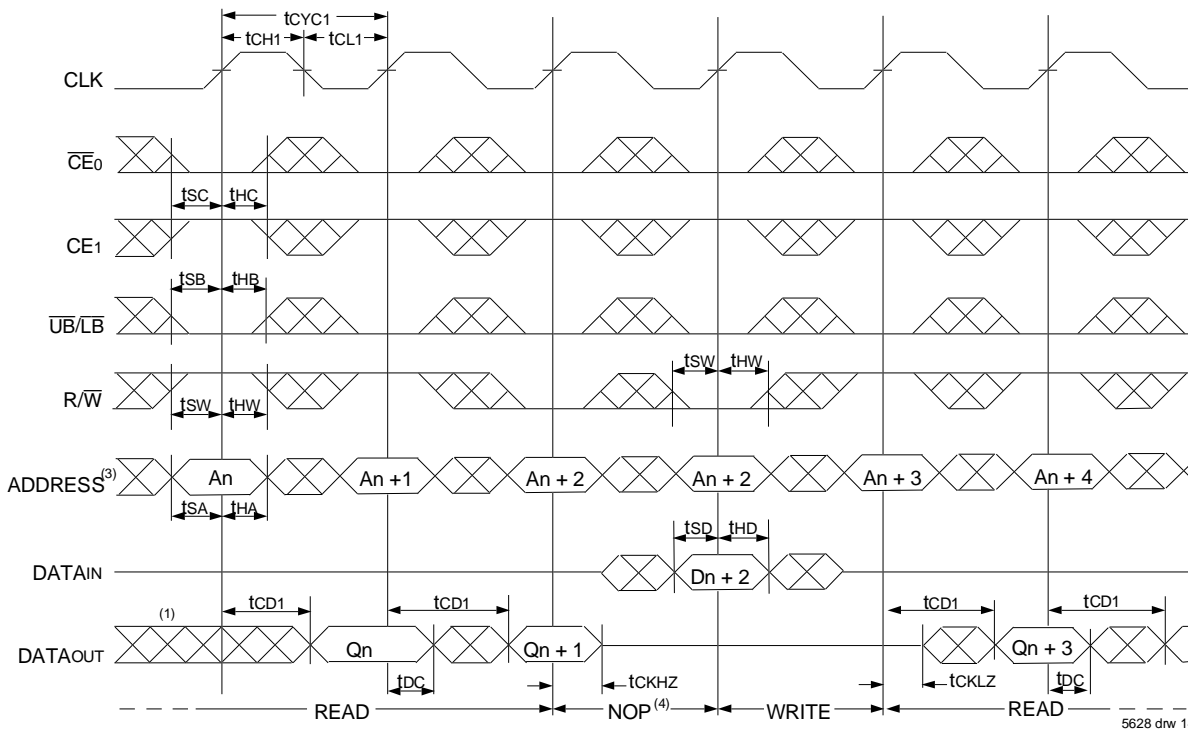

### Timing Waveform of Flow-Through Read-to-Write-to-Read ( $\overline{OE}$ Controlled)<sup>(2)</sup>

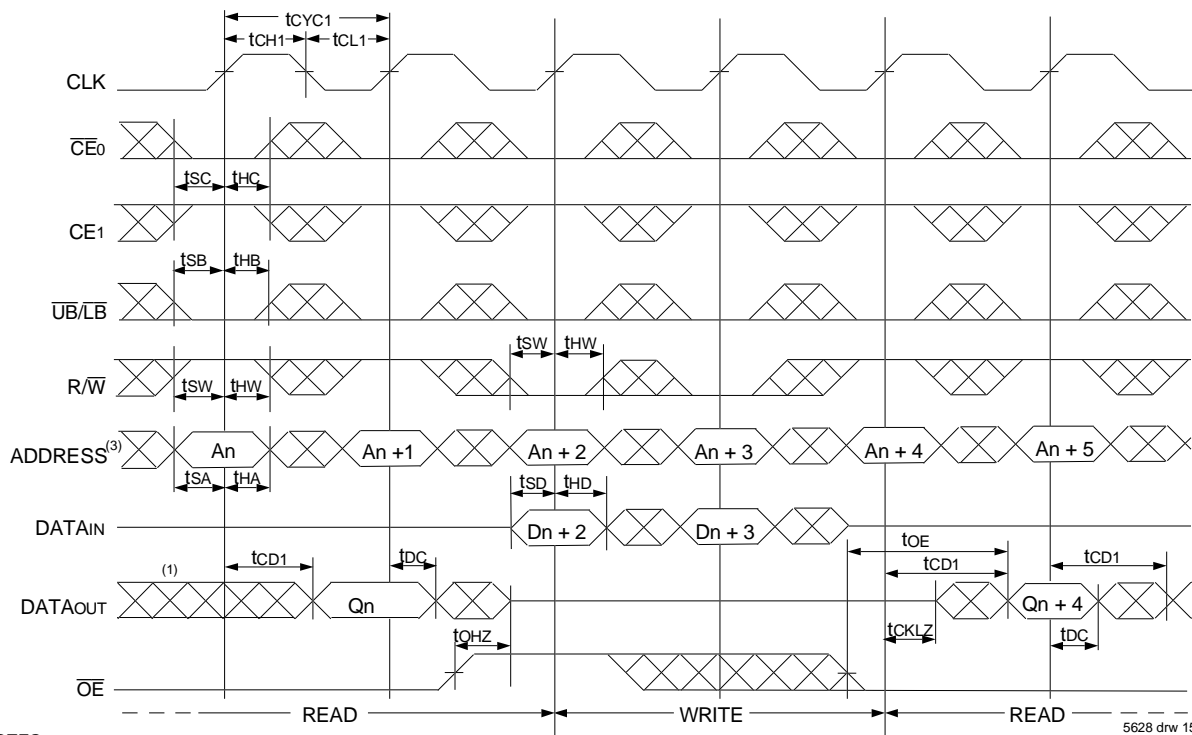

**NOTES:**

1. Output state (High, Low, or High-impedance) is determined by the previous cycle control signals.
2.  $\overline{CE}_0$ ,  $\overline{UB/LB}$ , and  $\overline{ADS} = V_{IL}$ ;  $\overline{CE}_1$ ,  $\overline{CNTEN}$ , and  $\overline{REPEAT} = V_{IH}$ .
3. Addresses do not have to be accessed sequentially since  $\overline{ADS} = V_{IL}$  constantly loads the address on the rising edge of the CLK; numbers are for reference use only.
4. "NOP" is "No Operation." Data in memory at the selected address may be corrupted and should be re-written to guarantee data integrity.

### Timing Waveform of Pipelined Read with Address Counter Advance<sup>(1)</sup>

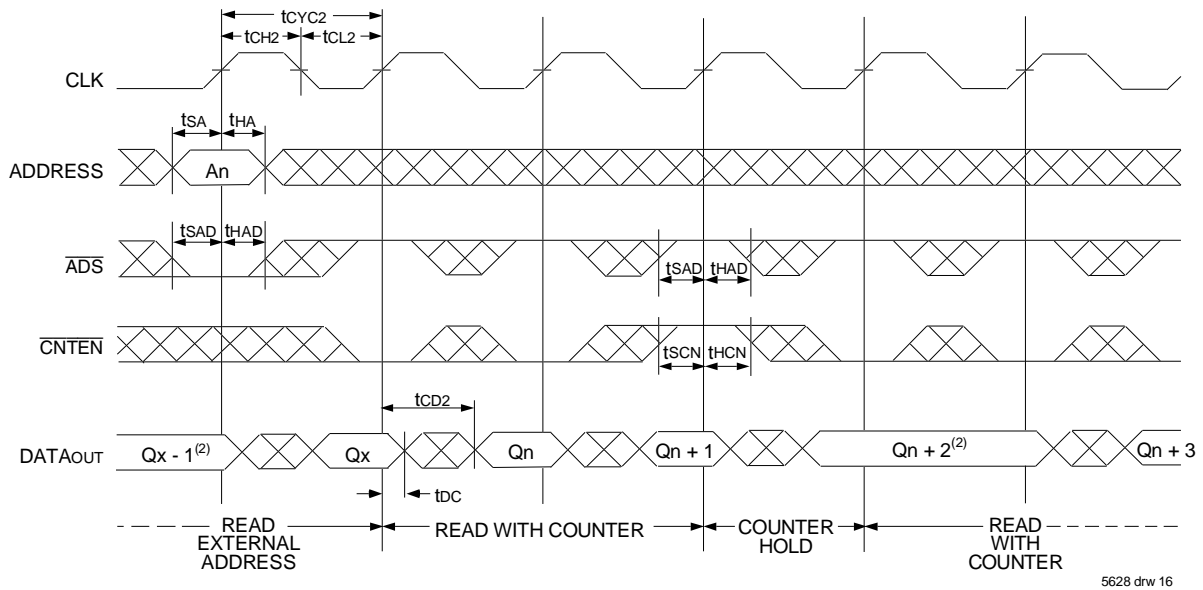

### Timing Waveform of Flow-Through Read with Address Counter Advance<sup>(1)</sup>

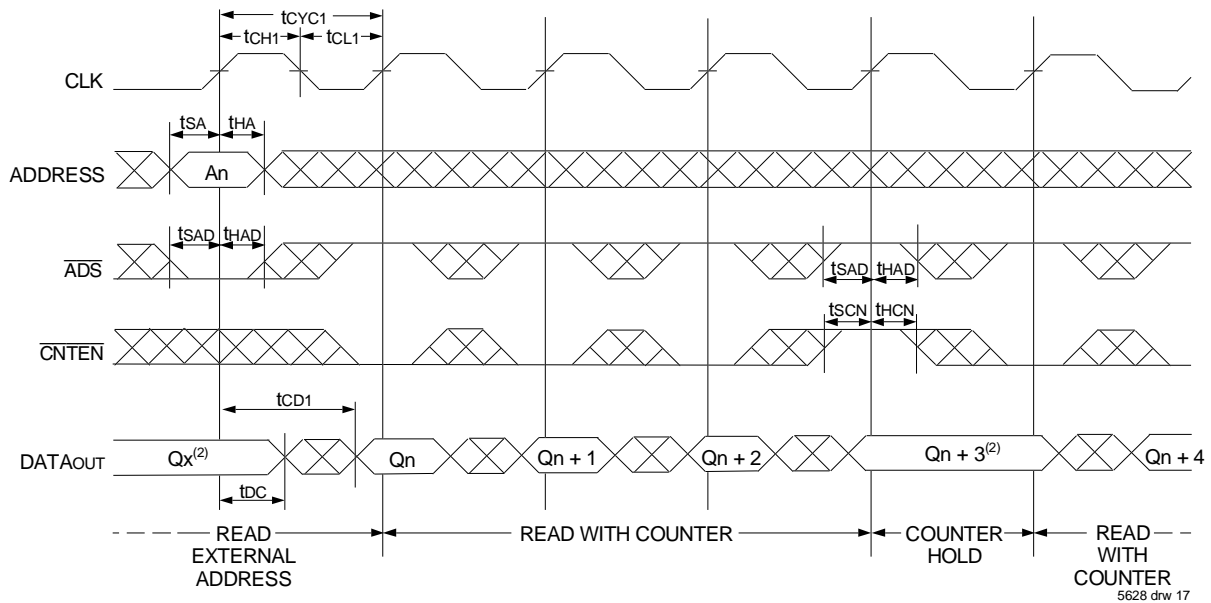

**NOTES:**

1.  $\overline{CE}_0$ ,  $\overline{OE}$ ,  $\overline{UB/LB}$  =  $V_{IL}$ ;  $CE_1$ ,  $R/\overline{W}$ , and  $\overline{REPEAT}$  =  $V_{IH}$ .
2. If there is no address change via  $\overline{ADS} = V_{IL}$  (loading a new address) or  $\overline{CNTEN} = V_{IL}$  (advancing the address), i.e.  $\overline{ADS} = V_{IH}$  and  $\overline{CNTEN} = V_{IH}$ , then the data output remains constant for subsequent clocks.

## Timing Waveform of Write with Address Counter Advance (Flow-through or Pipelined Inputs)<sup>(1,6)</sup>

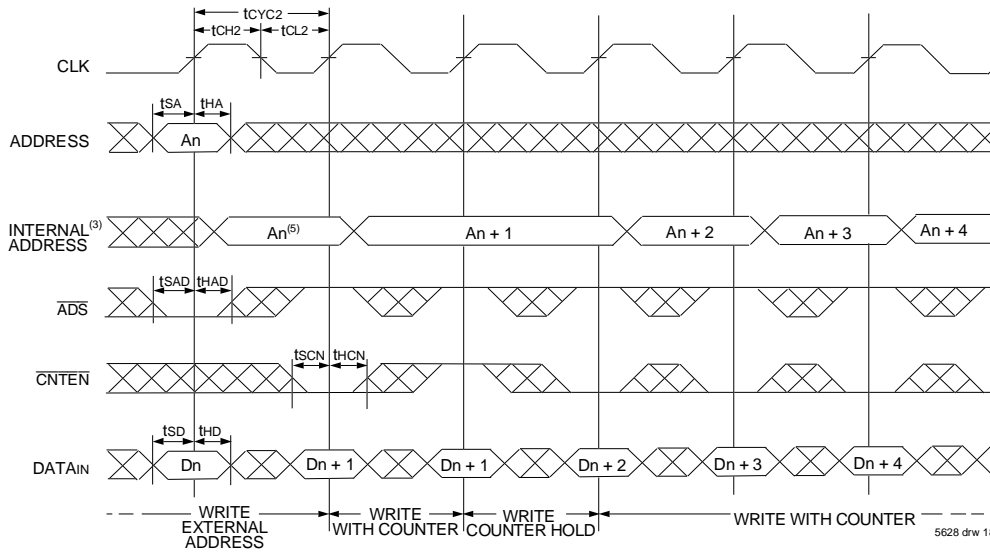

## Timing Waveform of Counter Repeat for Flow Through Mode<sup>(2,6,7)</sup>

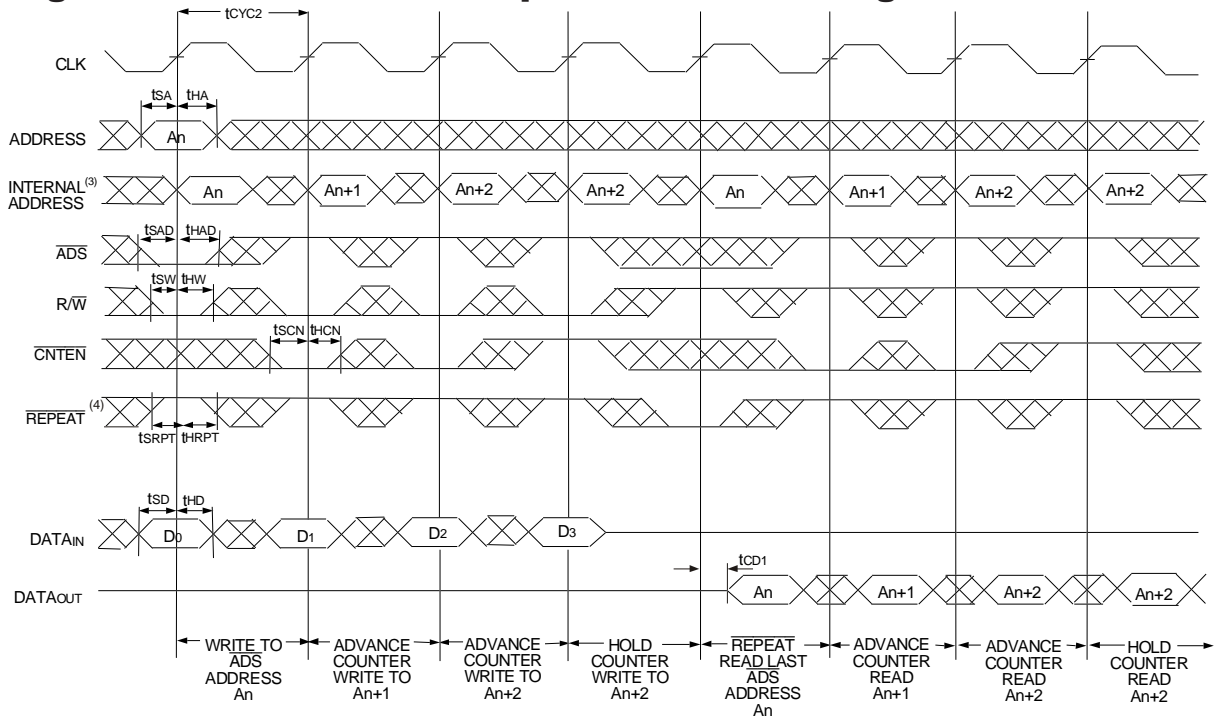

**NOTES:**

1.  $\overline{CE_0}$ ,  $\overline{UB/LB}$ , and  $R/\overline{W} = V_{IL}$ ;  $CE_1$  and  $\overline{REPEAT} = V_{IH}$ .
2.  $\overline{CE_0}$ ,  $\overline{UB/LB} = V_{IL}$ ;  $CE_1 = V_{IH}$ .
3. The "Internal Address" is equal to the "External Address" when  $\overline{ADS} = V_{IL}$  and equals the counter output when  $\overline{ADS} = V_{IH}$ .
4. No dead cycle exists during  $\overline{REPEAT}$  operation. A READ or WRITE cycle may be coincidental with the counter  $\overline{REPEAT}$  cycle: Address loaded by last valid  $\overline{ADS}$  load will be accessed. For more information on  $\overline{REPEAT}$  function refer to Truth Table II.
5.  $\overline{CNTEN} = V_{IL}$  advances Internal Address from 'An' to 'An + 1'. The transition shown indicates the time required for the counter to advance. The 'An + 1' Address is written to during this cycle.
6. The counter includes bank address and internal address. The counter will advance across bank boundaries. For example, if the counter is in Bank 0, at address FFFh, and is advanced one location, it will move to address 0h in Bank 1. By the same token, the counter at FFFh in Bank 63 will advance to 0h in Bank 0.
7. For Pipelined Mode user should add 1 cycle latency for outputs as per timing waveform of read cycle for pipelined operations.

## Functional Description

The IDT70V7339 is a high-speed 512Kx18 (9 Mbit) synchronous Bank-Switchable Dual-Ported SRAM organized into 64 independent 8Kx18 banks. Based on a standard SRAM core instead of a traditional true dual-port memory core, this bank-switchable device offers the benefits of increased density and lower cost-per-bit while retaining many of the features of true dual-ports. These features include simultaneous, random access to the shared array, separate clocks per port, 166 MHz operating speed, full-boundary counters, and pinouts compatible with the IDT70V3319 (256Kx18) dual-port family.

The two ports are permitted independent, simultaneous access into separate banks within the shared array. Access by the ports into specific banks are controlled by the bank address pins under the user's direct control: each port can access any bank of memory with the shared array that is not currently being accessed by the opposite port (i.e., BA0L - BA5L ≠ BA0R - BA5R). In the event that both ports try to access the same bank at the same time, neither access will be valid, and data at the two specific addresses targeted by the ports within that bank may be corrupted (in the case that either or both ports are writing) or may result in invalid output (in the case that both ports are trying to read).

The IDT70V7339 provides a true synchronous Dual-Port Static RAM

interface. Registered inputs provide minimal setup and hold times on address, data and all critical control inputs.

An asynchronous output enable is provided to ease asynchronous bus interfacing. Counter enable inputs are also provided to stall the operation of the address counters for fast interleaved memory applications.

A HIGH on  $\overline{CE}_0$  or a LOW on CE1 for one clock cycle will power down the internal circuitry on each port (individually controlled) to reduce static power consumption. Dual chip enables allow easier banking of multiple IDT70V7339s for depth expansion configurations. Two cycles are required with  $\overline{CE}_0$  LOW and CE1 HIGH to read valid data on the outputs.

## Depth and Width Expansion

The IDT70V7339 features dual chip enables (refer to Truth Table I) in order to facilitate rapid and simple depth expansion with no requirements for external logic. Figure 4 illustrates how to control the various chip enables in order to expand two devices in depth.

The IDT70V7339 can also be used in applications requiring expanded width, as indicated in Figure 4. Through combining the control signals, the devices can be grouped as necessary to accommodate applications needing 36-bits or wider.

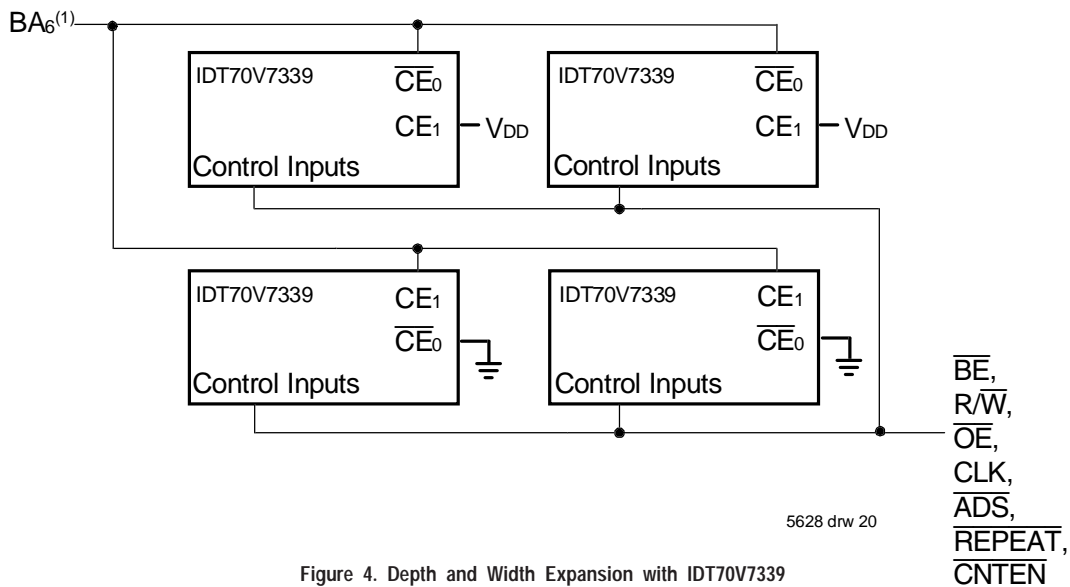
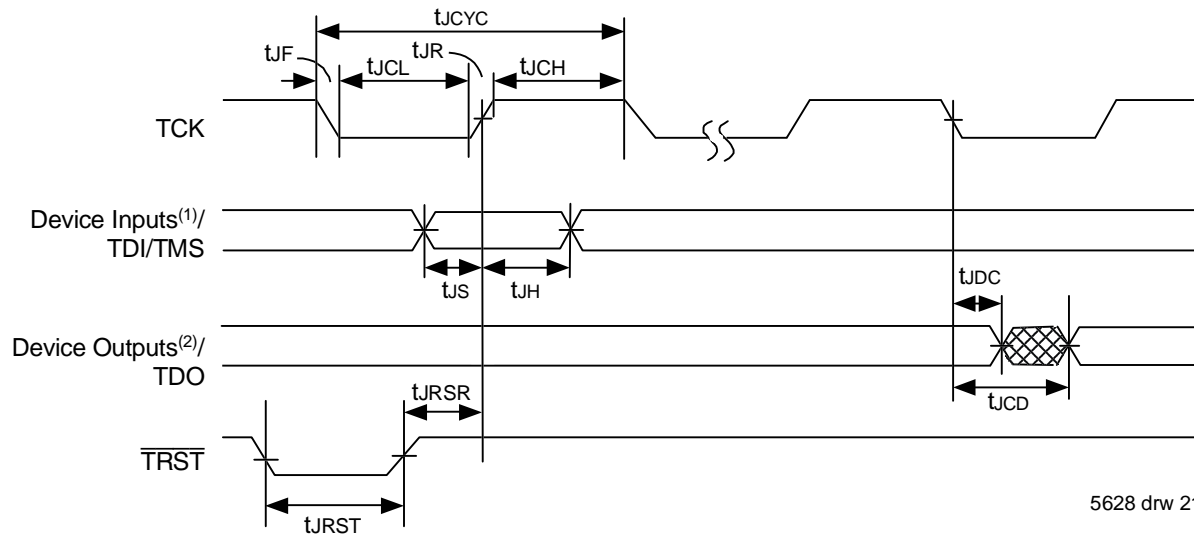

Figure 4. Depth and Width Expansion with IDT70V7339

**NOTE:**

1. In the case of depth expansion, the additional address pin logically serves as an extension of the bank address. Accesses by the ports into specific banks are controlled by the bank address pins under the user's direct control: each port can access any bank of memory within the shared array that is not currently being accessed by the opposite port (i.e., BA0L - BA6L ≠ BA0R - BA6R). In the event that both ports try to access the same bank at the same time, neither access will be valid, and data at the two specific addresses targeted by the parts within that bank may be corrupted (in the case that either or both parts are writing) or may result in invalid output (in the case that both ports are trying to read).

## JTAG Timing Specifications



5628 drw 21

Figure 5. Standard JTAG Timing

### NOTES:

1. Device inputs = All device inputs except TDI, TMS, TRST, and TCK.
2. Device outputs = All device outputs except TDO.

## JTAG AC Electrical Characteristics<sup>(1,2,3,4)</sup>

| Symbol     | Parameter               | 70V7339 |                  |       |
|------------|-------------------------|---------|------------------|-------|
|            |                         | Min.    | Max.             | Units |
| $t_{JCYC}$ | JTAG Clock Input Period | 100     | —                | ns    |
| $t_{JCH}$  | JTAG Clock HIGH         | 40      | —                | ns    |
| $t_{JCL}$  | JTAG Clock Low          | 40      | —                | ns    |
| $t_{JR}$   | JTAG Clock Rise Time    | —       | 3 <sup>(1)</sup> | ns    |
| $t_{JF}$   | JTAG Clock Fall Time    | —       | 3 <sup>(1)</sup> | ns    |
| $t_{JRST}$ | JTAG Reset              | 50      | —                | ns    |
| $t_{JRSR}$ | JTAG Reset Recovery     | 50      | —                | ns    |
| $t_{JCD}$  | JTAG Data Output        | —       | 25               | ns    |
| $t_{JDC}$  | JTAG Data Output Hold   | 0       | —                | ns    |
| $t_{JS}$   | JTAG Setup              | 15      | —                | ns    |
| $t_{JH}$   | JTAG Hold               | 15      | —                | ns    |

5628 tbl 12

### NOTES:

1. Guaranteed by design.
2. 30pF loading on external output signals.
3. Refer to AC Electrical Test Conditions stated earlier in this document.
4. JTAG operations occur at one speed (10MHz). The base device may run at any speed specified in this datasheet.

## Identification Register Definitions

| Instruction Field                 | Value | Description  |
|-----------------------------------|-------|--|
| Revision Number (31:28)           | 0x0   | Reserved for version number                          |
| IDT Device ID (27:12)             | 0x301 | Defines IDT part number                              |
| IDT JEDEC ID (11:1)               | 0x33  | Allows unique identification of device vendor as IDT |
| ID Register Indicator Bit (Bit 0) | 1     | Indicates the presence of an ID register             |

5628 tbl 13

## Scan Register Sizes

| Register Name        | Bit Size |
|----------------------|----------|
| Instruction (IR)     | 4        |
| Bypass (BYR)         | 1        |
| Identification (IDR) | 32       |
| Boundary Scan (BSR)  | Note (3) |

5628 tbl 14

## System Interface Parameters

| Instruction    | Code            | Description   |
|----------------|-----------------|---|
| EXTEST         | 0000            | Forces contents of the boundary scan cells onto the device outputs <sup>(1)</sup> . Places the boundary scan register (BSR) between TDI and TDO.  |
| BYPASS         | 1111            | Places the bypass register (BYR) between TDI and TDO.   |
| IDCODE         | 0010            | Loads the ID register (IDR) with the vendor ID code and places the register between TDI and TDO.  |
| HIGHZ          | 0100            | Places the bypass register (BYR) between TDI and TDO. Forces all device output drivers to a High-Z state.   |
| CLAMP          | 0011            | Uses BYR. Forces contents of the boundary scan cells onto the device outputs. Places the bypass register (BYR) between TDI and TDO.   |
| SAMPLE/PRELOAD | 0001            | Places the boundary scan register (BSR) between TDI and TDO. SAMPLE allows data from device inputs <sup>(2)</sup> and outputs <sup>(1)</sup> to be captured in the boundary scan cells and shifted serially through TDO. PRELOAD allows data to be input serially into the boundary scan cells via the TDI. |
| RESERVED       | All other codes | Several combinations are reserved. Do not use codes other than those identified above.  |

5628 tbl 15

### NOTES:

1. Device outputs = All device outputs except TDO.
2. Device inputs = All device inputs except TDI, TMS, TRST, and TCK.
3. The Boundary Scan Descriptive Language (BSDL) file for this device is available on the IDT website ([www.idt.com](http://www.idt.com)), or by contacting your local IDT sales representative.

## Ordering Information

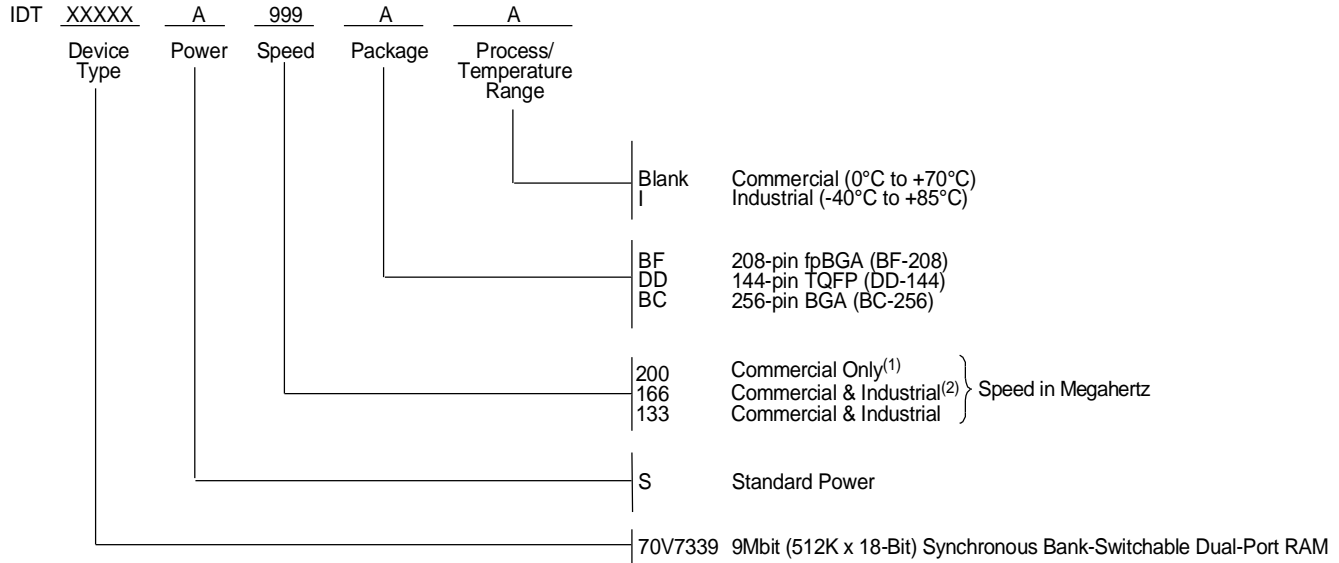

5628 drw 22

### NOTES:

1. Available in BC-256 package only.
2. Industrial Temperature at 166Mhz not available in BF-208 package.

## Datasheet Document History:

|           |  |
|-----------|--|
| 1/5/00:   | Initial Public Offering  |
| 6/20/01:  | Page 1 Added JTAG information for TQFP package<br>Page 4 & 22 Changed TQFP package from DA to DD<br>Corrected Pin number on TQFP package from 100 to 110<br>Page 20 Increased $t_{\text{UCD}}$ from 20ns to 25ns   |
| 8/6/01:   | Page 4 Changed body size for DD package from 22mm x 22mm x 1.6mm to 20mm x 20mm x 1.4mm<br>Page 9 Changed $I_{\text{SB3}}$ values for commercial and industrial DC Electrical Characteristics  |
| 11/20/01: | Page 2, 3 & 4 Added date revision for pin configurations<br>Page 11 Changed to $t_{\text{OE}}$ value in AC Electrical Characteristics, please refer to Errata #SMEN-01-05<br>Page 1 & 22 Replaced $\text{TM}$ logo with $\text{®}$ logo                    |
| 03/18/02: | Page 1, 9, 11 & 22 Added 200MHZ specification<br>Page 9 Tightened power numbers in DC Electrical Characteristics<br>Page 14 Changed waveforms to show INVALID operation if $t_{\text{CO}} <$ minimum specified<br>Page 1 - 22 Removed "Preliminary" status |
| 12/4/02:  | Page 9, 11 & 22 Designated 200Mhz speed grade in BC-256 package only.  |



**CORPORATE HEADQUARTERS**  
2975 Stender Way  
Santa Clara, CA 95054

**for SALES:**  
800-345-7015 or 408-727-5166  
fax: 408-492-8674  
www.idt.com

**for Tech Support:**  
831-754-4613  
DualPortHelp@idt.com

The IDT logo is a registered trademark of Integrated Device Technology, Inc.

Copyright © Each Manufacturing Company.

All Datasheets cannot be modified without permission.

This datasheet has been download from :

[www.AllDataSheet.com](http://www.AllDataSheet.com)

100% Free DataSheet Search Site.

Free Download.

No Register.

Fast Search System.

[www.AllDataSheet.com](http://www.AllDataSheet.com)