

DATA SHEET

74LVC4066 Quad bilateral switches

Product specification

2003 Aug 12

Quad bilateral switches

74LVC4066

FEATURES

- Very low ON resistance:
 - 7.5 Ω (typical) at $V_{CC} = 2.7$ V
 - 6.5 Ω (typical) at $V_{CC} = 3.3$ V
 - 6 Ω (typical) at $V_{CC} = 5$ V.
- ESD protection:
 - HBM EIA/JESD22-A114-A Exceeds 2000 V
 - MM EIA/JESD22-A115-A Exceeds 200 V.
- High noise immunity
- CMOS low power consumption
- Latch up performance exceeds 250 mA
- Complies with JEDEC standard no. 8-1A
- Direct interface TTL-levels.

DESCRIPTION

The 74LVC4066 is a high-speed Si-gate CMOS device.

The 74LVC4066 has four independent analog switches. Each switch has two input/output terminals (nY and nZ) and an active HIGH enable input (nE). When nE is LOW, the analog switch is turned off.

QUICK REFERENCE DATA

GND = 0 V; $T_{amb} = 25$ °C; $t_r = t_f \leq 2.5$ ns.

SYMBOL	PARAMETER	CONDITIONS	TYPICAL	UNIT
t_{PZH}/t_{PZL}	turn-on time E to V_{os}	$C_L = 50$ pF; $R_L = 500$ Ω ; $V_{CC} = 3$ V	2.5	ns
		$C_L = 50$ pF; $R_L = 500$ Ω ; $V_{CC} = 5$ V	1.9	ns
t_{PHZ}/t_{PLZ}	turn-off time E to V_{os}	$C_L = 50$ pF; $R_L = 500$ Ω ; $V_{CC} = 3$ V	3.4	ns
		$C_L = 50$ pF; $R_L = 500$ Ω ; $V_{CC} = 5$ V	2.5	ns
C_I	input capacitance	$V_{CC} = 3$ V	3.5	pF
C_{PD}	power dissipation capacitance	$V_{CC} = 3.3$ V; notes 1 and 2	12.5	pF
C_S	switch capacitance	OFF-state	8.0	pF
		ON-state	14.0	pF

Notes

1. C_{PD} is used to determine the dynamic power dissipation (P_D in μ W).

$$P_D = C_{PD} \times V_{CC}^2 \times f_i \times N + ((C_L + C_S) \times V_{CC}^2 \times f_o) \text{ where:}$$

f_i = input frequency in MHz;

f_o = output frequency in MHz;

C_L = output load capacitance in pF;

V_{CC} = supply voltage in Volts;

N = total load switching outputs;

C_S = switch capacitance.

2. The condition is $V_I = \text{GND to } V_{CC}$.

Quad bilateral switches

74LVC4066

FUNCTION TABLE

See note 1.

INPUT nE	SWITCH
L	OFF
H	ON

Note

- 1. H = HIGH voltage level;
L = LOW voltage level.

ORDERING INFORMATION

TYPE NUMBER	PACKAGE				
	TEMPERATURE RANGE	PINS	PACKAGE	MATERIAL	CODE
74LVC4066D	-40 to +125 °C	14	SO14	plastic	SOT108-2
74LVC4066PW	-40 to +125 °C	14	TSSOP14	plastic	SOT402-1
74LVC4066BQ	-40 to +125 °C	14	DHVQFN14	plastic	SOT762-1

PINNING

PIN	SYMBOL	DESCRIPTION
1	1Y	independent input/output
2	1Z	independent output/input
3	2Z	independent output/input
4	2Y	independent input/output
5	2E	enable input (active HIGH)
6	3E	enable input (active HIGH)
7	GND	ground (0 V)
8	3Y	independent input/output
9	3Z	independent output/input
10	4Z	independent output/input
11	4Y	independent input/output
12	4E	enable input (active HIGH)
13	1E	enable input (active HIGH)
14	V _{CC}	supply voltage

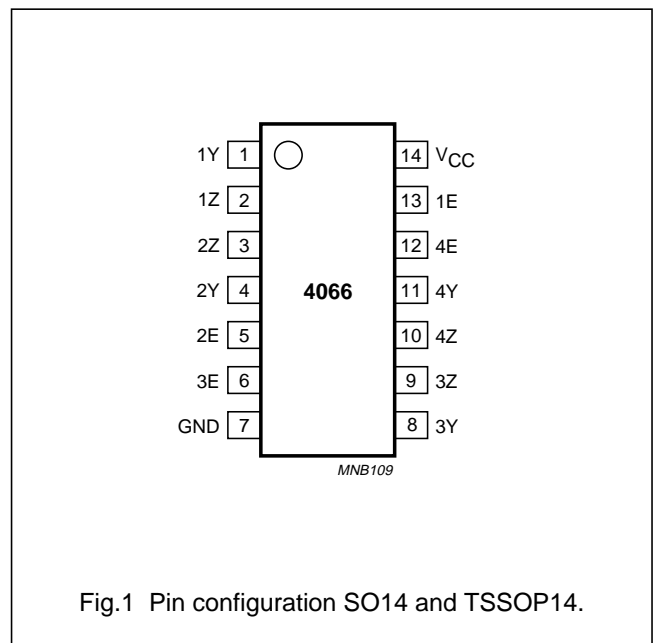
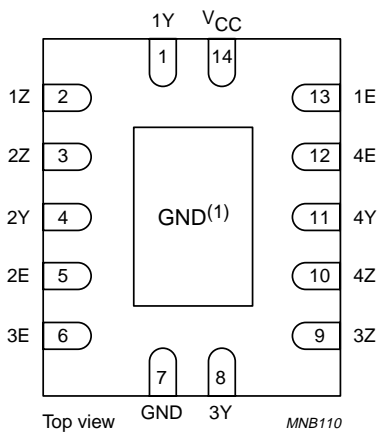

Fig.1 Pin configuration SO14 and TSSOP14.

Quad bilateral switches

74LVC4066



(1) The die substrate is attached to this pad using conductive die attach material. It can not be used as a supply pin or input.

Fig.2 Pin configuration DHVQFN14.

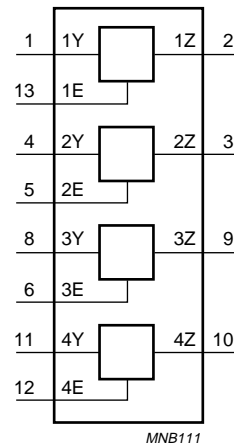

Fig.3 Logic symbol.

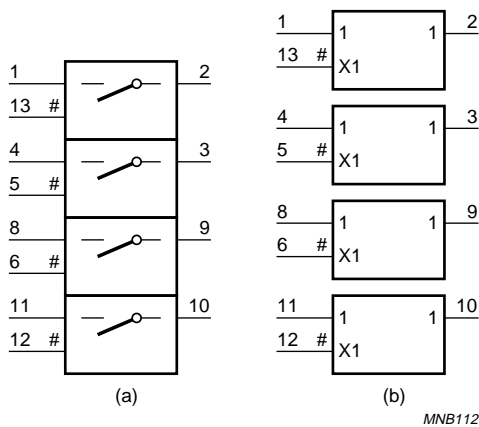

Fig.4 logic symbol (IEEE/IEC).

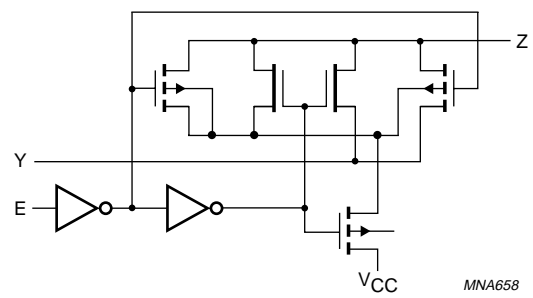

Fig.5 Logic diagram (one switch).

Quad bilateral switches

74LVC4066

RECOMMENDED OPERATING CONDITIONS

SYMBOL	PARAMETER	CONDITIONS	MIN.	MAX.	UNIT
V_{CC}	supply voltage		1.65	5.5	V
V_I	input voltage		0	5.5	V
V_S	switch voltage		0	V_{CC}	V
T_{amb}	operating ambient temperature		-40	+125	°C
t_r, t_f	input rise and fall times	$V_{CC} = 1.65$ to 2.7 V	0	20	ns/V
		$V_{CC} = 2.7$ to 5.5 V	0	10	ns/V

LIMITING VALUES

In accordance with the Absolute Maximum Rating System (IEC 60134); voltages are referenced to GND (ground = 0 V); see note 1.

SYMBOL	PARAMETER	CONDITIONS	MIN.	MAX.	UNIT
V_{CC}	supply voltage		-0.5	+6.5	V
V_I	input voltage	note 2	-0.5	+6.5	V
I_{IK}	input diode current	$V_I < -0.5$ V or $V_I > V_{CC} + 0.5$ V	-	-50	mA
I_{SK}	switch diode current	$V_I < -0.5$ V or $V_I > V_{CC} + 0.5$ V	-	±50	mA
V_S	switch voltage	enable and disable mode	-0.5	+6.5	V
I_S	switch source or sink current	$-0.5 < V_S < V_{CC} + 0.5$ V	-	±50	mA
I_{CC}, I_{GND}	V_{CC} or GND current		-	±100	mA
T_{stg}	storage temperature		-65	+150	°C
P_{tot}	power dissipation	$T_{amb} = -40$ to $+125$ °C; note 3	-	500	mW

Notes

- To avoid drawing V_{CC} current out of terminal Z, when switch current flows in terminal Y, the voltage drop across the bidirectional switch must not exceed 0.4 V. If the switch current flows into terminal Z, no V_{CC} current will flow out of terminal Y. In this case there is no limit for the voltage drop across the switch, but the voltage at Y and Z may not exceed V_{CC} or GND.
- The input and output voltage ratings may be exceeded if the input and output current ratings are observed.
- For SO14 packages: above 70 °C derate linearly with 8 mW/K.
For TSSOP14 packages: above 60 °C derate linearly with 5.5 mW/K.
For DHVQFN14 packages: above 60 °C derate linearly with 4.5 mW/K.

Quad bilateral switches

74LVC4066

DC CHARACTERISTICS

At recommended operating conditions; voltage are referenced to GND (ground = 0 V).

SYMBOL	PARAMETER	TEST CONDITIONS		MIN.	TYP.	MAX.	UNIT
		OTHER	V _{CC} (V)				
T_{amb} = -40 to +85 °C; note 1							
V _{IH}	HIGH-level input voltage		1.65 to 1.95	0.65V _{CC}	–	–	V
			2.3 to 2.7	1.7	–	–	V
			2.7 to 3.6	2.0	–	–	V
			4.5 to 5.5	0.7V _{CC}	–	–	V
V _{IL}	LOW-level input voltage		1.65 to 1.95	–	–	0.35V _{CC}	V
			2.3 to 2.7	–	–	0.7	V
			2.7 to 3.6	–	–	0.8	V
			4.5 to 5.5	–	–	0.30V _{CC}	V
I _{LI}	input leakage current (control pin)	V _I = 5.5 V or GND	5.5	–	±0.1	±5	μA
I _{S(OFF)}	analog switch OFF-state current	V _I = V _{IH} or V _{IL} ; V _S = V _{CC} – GND; see Fig.7	5.5	–	±0.1	±5	μA
I _{S(ON)}	analog switch ON-state current	V _I = V _{IH} or V _{IL} ; V _S = V _{CC} – GND; see Fig.8	5.5	–	±0.1	±5	μA
I _{CC}	quiescent supply current	V _I = V _{CC} or GND; V _S = GND or V _{CC} ; I _O = 0 A	5.5	–	0.1	10	μA
ΔI _{CC}	additional quiescent supply current per control pin	V _I = V _{CC} – 0.6 V; V _S = GND or V _{CC} ; I _O = 0 A	5.5	–	5	500	μA

Quad bilateral switches

74LVC4066

SYMBOL	PARAMETER	TEST CONDITIONS		MIN.	TYP.	MAX.	UNIT
		OTHER	V _{CC} (V)				
T_{amb} = -40 to +125 °C							
V _{IH}	HIGH-level input voltage		1.65 to 1.95	0.65V _{CC}	–	–	V
			2.3 to 2.7	1.7	–	–	V
			2.7 to 3.6	2.0	–	–	V
			4.5 to 5.5	0.7V _{CC}	–	–	V
V _{IL}	LOW-level input voltage		1.65 to 1.95	–	–	0.35V _{CC}	V
			2.3 to 2.7	–	–	0.7	V
			2.7 to 3.6	–	–	0.8	V
			4.5 to 5.5	–	–	0.30V _{CC}	V
I _{LI}	input leakage current (control pin)	V _I = 5.5 V or GND	5.5	–	–	±20	μA
I _{S(OFF)}	analog switch OFF-state current	V _I = V _{IH} or V _{IL} ; V _S = V _{CC} – GND; see Fig.7	5.5	–	–	±20	μA
I _{S(ON)}	analog switch ON-state current	V _I = V _{IH} or V _{IL} ; V _S = V _{CC} – GND; see Fig.8	5.5	–	–	±20	μA
I _{CC}	quiescent supply current	V _I = V _{CC} or GND; V _S = GND or V _{CC} ; I _O = 0 A	5.5	–	–	40	μA
ΔI _{CC}	additional quiescent supply current per control pin	V _I = V _{CC} – 0.6 V; V _S = GND or V _{CC} ; I _O = 0 A	5.5	–	–	5000	μA

Note

1. All typical values are measured at T_{amb} = 25 °C.

Quad bilateral switches

74LVC4066

Resistance R_{ON}

SYMBOL	PARAMETER	TEST CONDITIONS			MIN.	TYP.	MAX.	UNIT
		OTHER	I_S (mA)	V_{CC} (V)				
$T_{amb} = -40$ to $+85$ °C; note 1; see Fig.6								
$R_{ON(peak)}$	ON-resistance (peak)	$V_S = GND$ to V_{CC} ; $V_I = V_{IH}$	4	1.65 to 1.95	–	35	100	Ω
			8	2.3 to 2.7	–	14	30	Ω
			12	2.7	–	11.5	25	Ω
			24	3.0 to 3.6	–	8.5	20	Ω
			32	4.5 to 5.5	–	6.5	15	Ω
$R_{ON(rail)}$	ON-resistance (rail)	$V_S = GND$; $V_I = V_{IH}$	4	1.65 to 1.95	–	10	30	Ω
			8	2.3 to 2.7	–	8.5	20	Ω
			12	2.7	–	7.5	18	Ω
			24	3.0 to 3.6	–	6.5	15	Ω
			32	4.5 to 5.5	–	6	10	Ω
		$V_S = V_{CC}$; $V_I = V_{IH}$	4	1.65 to 1.95	–	12	30	Ω
			8	2.3 to 2.7	–	8.5	20	Ω
			12	2.7	–	7.5	18	Ω
			24	3.0 to 3.6	–	6.5	15	Ω
			32	4.5 to 5.5	–	6	10	Ω
$R_{ON(flatness)}$	ON-resistance (flatness)	$V_S = GND$ to V_{CC} ; $V_I = V_{IH}$; see Figs.10 to 13	4	1.8	–	100	–	Ω
			8	2.5	–	17	–	Ω
			12	2.7	–	10	–	Ω
			24	3.3	–	5	–	Ω
			32	5.0	–	3	–	Ω

Quad bilateral switches

74LVC4066

SYMBOL	PARAMETER	TEST CONDITIONS			MIN.	TYP.	MAX.	UNIT
		OTHER	I _S (mA)	V _{CC} (V)				
T_{amb} = -40 to +125 °C; see Fig.6								
R _{ON(peak)}	ON-resistance (peak)	V _S = GND to V _{CC} ; V _I = V _{IH}	4	1.65 to 1.95	–	–	150	Ω
			8	2.3 to 2.7	–	–	45	Ω
			12	2.7	–	–	38	Ω
			24	3.0 to 3.6	–	–	30	Ω
			32	4.5 to 5.5	–	–	23	Ω
R _{ON(rail)}	ON-resistance (rail)	V _S = GND; V _I = V _{IH}	4	1.65 to 1.95	–	–	45	Ω
			8	2.3 to 2.7	–	–	30	Ω
			12	2.7	–	–	27	Ω
			24	3.0 to 3.6	–	–	23	Ω
			32	4.5 to 5.5	–	–	15	Ω
		V _S = V _{CC} ; V _I = V _{IH}	4	1.65 to 1.95	–	–	45	Ω
			8	2.3 to 2.7	–	–	30	Ω
			12	2.7	–	–	27	Ω
			24	3.0 to 3.6	–	–	23	Ω
			32	4.5 to 5.5	–	–	15	Ω

Note

1. Typical value R_{on(flatness)} is measured at T_{amb} = -40 to +85 °C, all other typical values are measured at T_{amb} = 25 °C.

Quad bilateral switches

74LVC4066

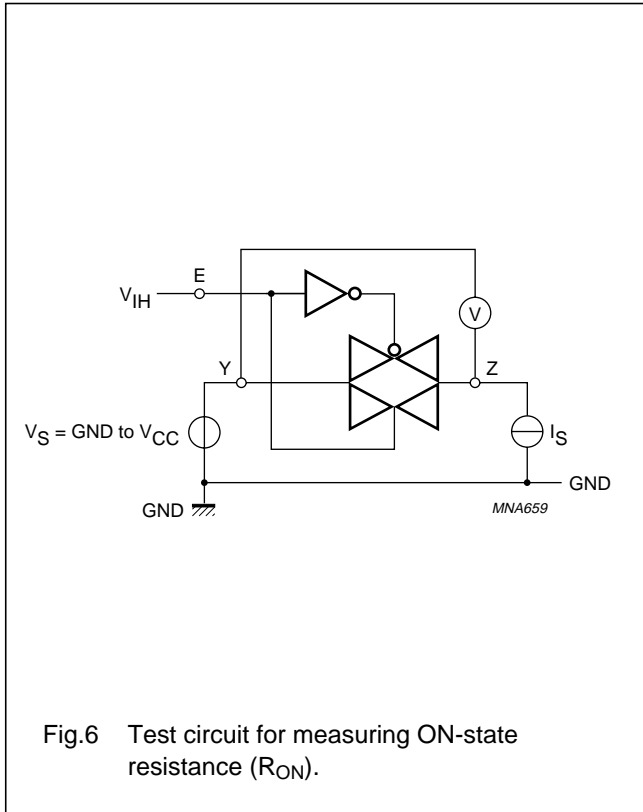

Fig.6 Test circuit for measuring ON-state resistance (R_{ON}).

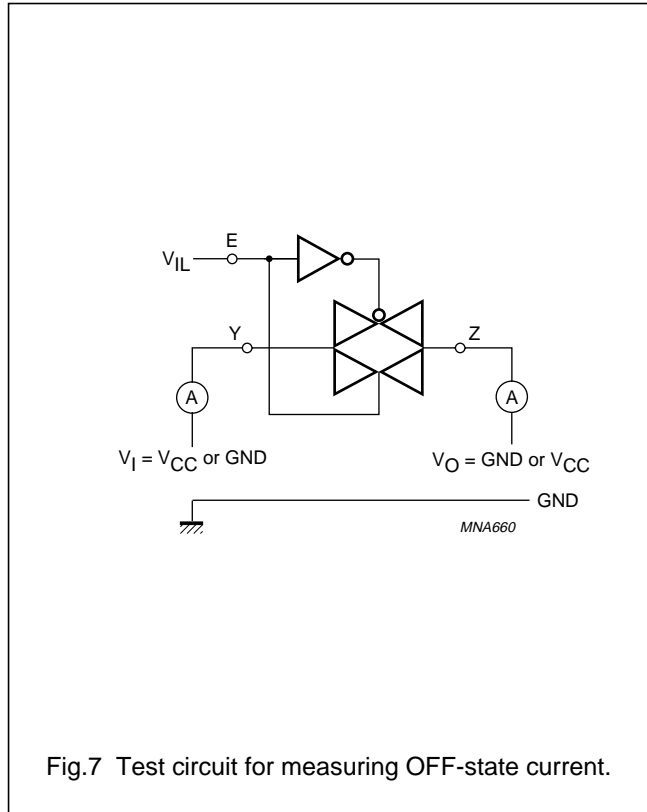

Fig.7 Test circuit for measuring OFF-state current.

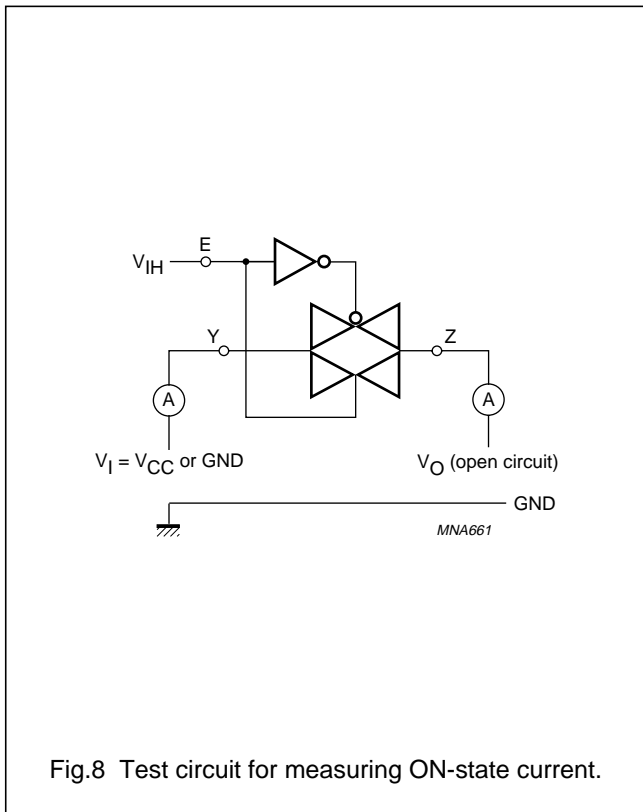

Fig.8 Test circuit for measuring ON-state current.

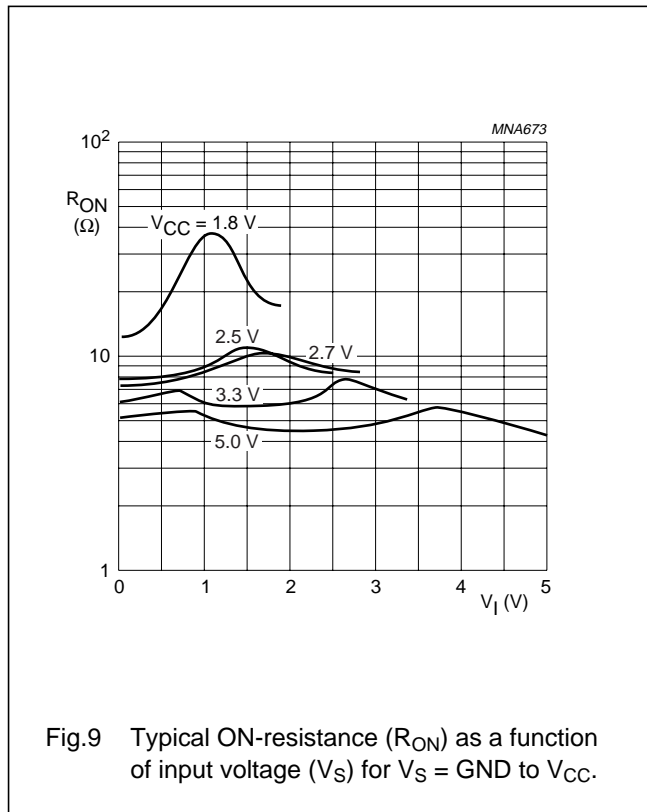
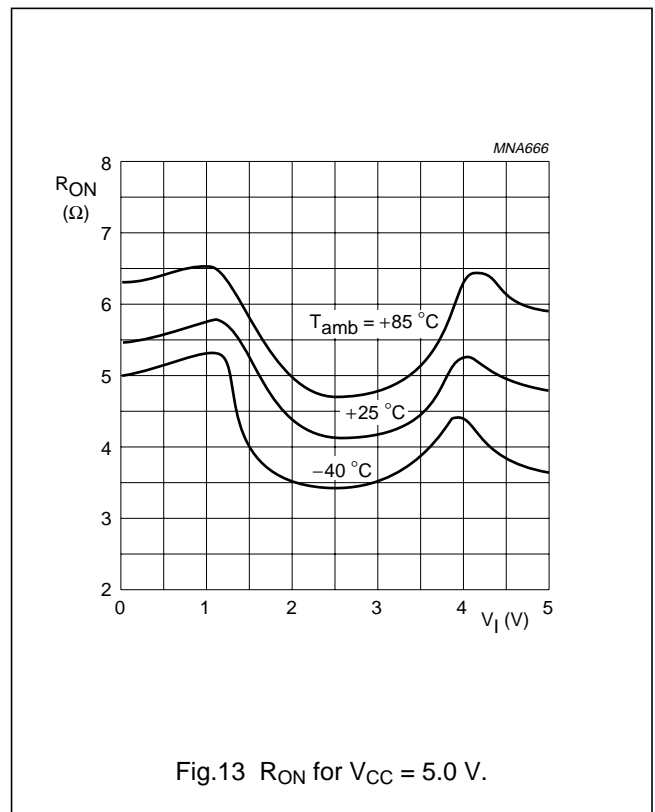
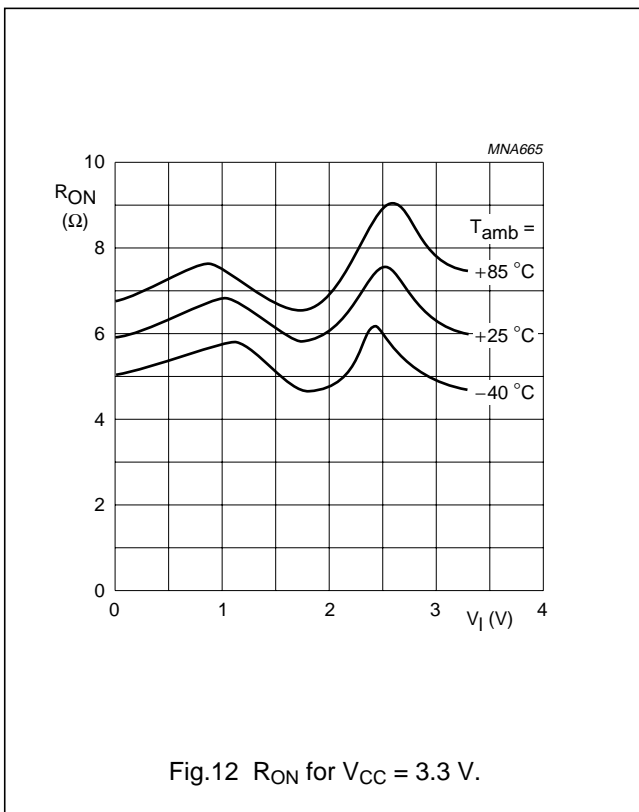
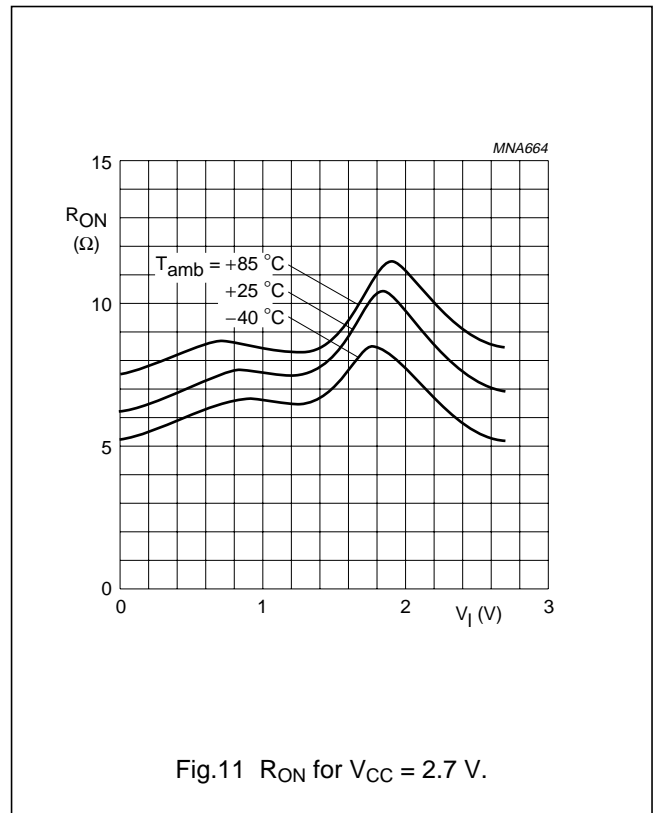
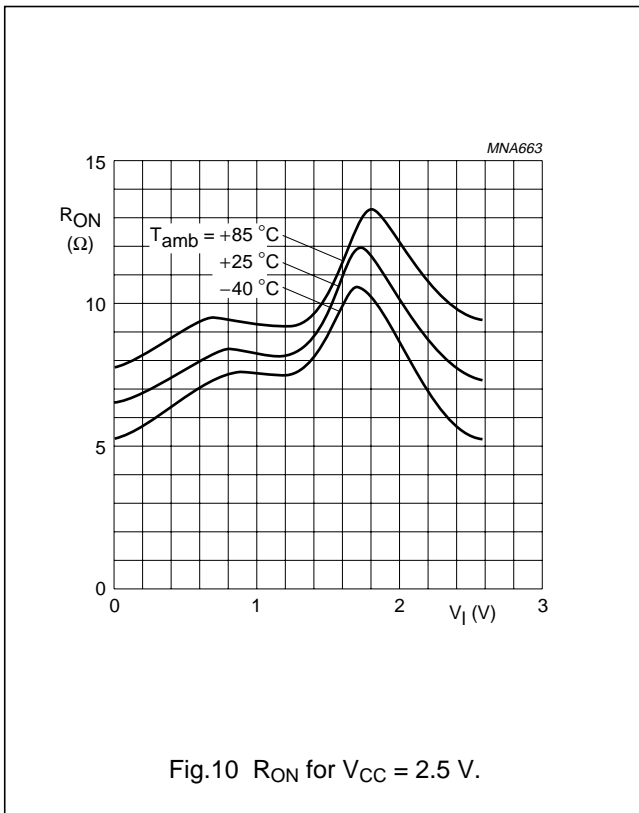

Fig.9 Typical ON-resistance (R_{ON}) as a function of input voltage (V_S) for $V_S = \text{GND to } V_{CC}$.

Quad bilateral switches

74LVC4066



Quad bilateral switches

74LVC4066

AC CHARACTERISTICS

GND = 0 V.

SYMBOL	PARAMETER	TEST CONDITIONS		MIN.	TYP.	MAX.	UNIT
		WAVEFORMS	V _{CC} (V)				
T_{amb} = -40 to +85 °C; note 1							
t _{PHL} /t _{PLH}	propagation delay nY to nZ or nZ to nY	see Figs 14 and 16; note 2	1.65 to 1.95	–	0.8	2.0	ns
			2.3 to 2.7	–	0.4	1.2	ns
			2.7	–	0.4	1.0	ns
			3.0 to 3.6	–	0.3	0.8	ns
			4.5 to 5.5	–	0.2	0.6	ns
t _{PZH} /t _{PZL}	turn-ON time E to V _{OS}	see Figs 15 and 16	1.65 to 1.95	1.0	5.3	10	ns
			2.3 to 2.7	1.0	3.0	5.6	ns
			2.7	1.0	2.6	5.0	ns
			3.0 to 3.6	1.0	2.5	4.4	ns
			4.5 to 5.5	1.0	1.9	3.9	ns
t _{PHZ} /t _{PLZ}	turn-OFF time E to V _{OS}	see Figs 15 and 16	1.65 to 1.95	1.0	4.2	9.0	ns
			2.3 to 2.7	1.0	2.4	5.5	ns
			2.7	1.0	3.6	6.5	ns
			3.0 to 3.6	1.0	3.4	6.0	ns
			4.5 to 5.5	1.0	2.5	5.0	ns
T_{amb} = -40 to +125 °C							
t _{PHL} /t _{PLH}	propagation delay nY to nZ or nZ to nY	see Figs 14 and 16; note 2	1.65 to 1.95	–	–	3.0	ns
			2.3 to 2.7	–	–	2.0	ns
			2.7	–	–	1.5	ns
			3.0 to 3.6	–	–	1.5	ns
			4.5 to 5.5	–	–	1.0	ns
t _{PZH} /t _{PZL}	turn-ON time E to V _{OS}	see Figs 15 and 16	1.65 to 1.95	1.0	–	12.5	ns
			2.3 to 2.7	1.0	–	7.0	ns
			2.7	1.0	–	6.5	ns
			3.0 to 3.6	1.0	–	5.5	ns
			4.5 to 5.5	1.0	–	5.0	ns
t _{PHZ} /t _{PLZ}	turn-OFF time E to V _{OS}	see Figs 15 and 16	1.65 to 1.95	1.0	–	11.5	ns
			2.3 to 2.7	1.0	–	7.0	ns
			2.7	1.0	–	8.5	ns
			3.0 to 3.6	1.0	–	7.5	ns
			4.5 to 5.5	1.0	–	6.5	ns

Notes

1. All typical values are measured at T_{amb} = 25 °C.
2. t_{PHL}/t_{PLH} propagation delay is the calculated RC time constant of the typical ON-state resistance of the switch and the specified capacitance when driven by an ideal voltage source (zero output impedance).

Quad bilateral switches

74LVC4066

AC WAVEFORMS

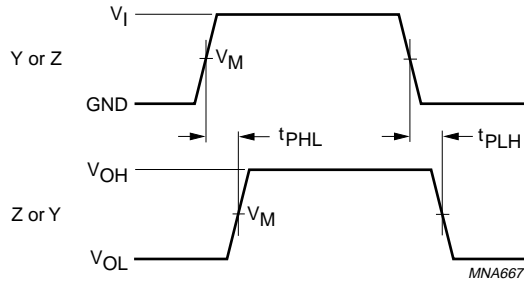

V _{CC}	V _M	INPUT	
		V _I	t _r = t _f
1.65 to 1.95 V	0.5V _{CC}	V _{CC}	≤ 2.0 ns
2.3 to 2.7 V	0.5V _{CC}	V _{CC}	≤ 2.0 ns
2.7 and 3.0 to 3.6 V	1.5 V	2.7 V	≤ 2.5 ns
4.5 to 5.5 V	0.5V _{CC}	V _{CC}	≤ 2.5 ns

V_{OL} and V_{OH} are typical output voltage drop that occur with the output load.

Fig.14 The input (V_S) to output (V_O) propagation delays.

Quad bilateral switches

74LVC4066

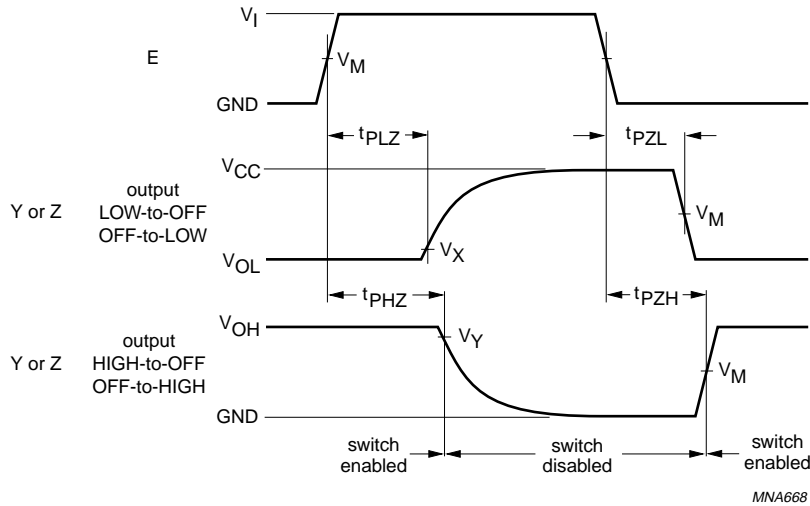

MNA668

V _{CC}	V _M	INPUT	
		V _I	t _r = t _f
1.65 to 1.95 V	0.5V _{CC}	V _{CC}	≤ 2.0 ns
2.3 to 2.7 V	0.5V _{CC}	V _{CC}	≤ 2.0 ns
2.7 and 3.0 to 3.6 V	1.5 V	2.7 V	≤ 2.5 ns
4.5 to 5.5 V	0.5V _{CC}	V _{CC}	≤ 2.5 ns

$V_X = V_{OL} + 0.3 \text{ V}$ at $V_{CC} \geq 2.7 \text{ V}$;
 $V_X = V_{OL} + 0.1 \times V_{CC}$ at $V_{CC} < 2.7 \text{ V}$;
 $V_Y = V_{OH} - 0.3 \text{ V}$ at $V_{CC} \geq 2.7 \text{ V}$;
 $V_Y = V_{OH} - 0.1 \times V_{CC}$ at $V_{CC} < 2.7 \text{ V}$.

V_{OL} and V_{OH} are typical output voltage drop that occur with the output load.

Fig.15 Turn-on and turn-off times.

Quad bilateral switches

74LVC4066

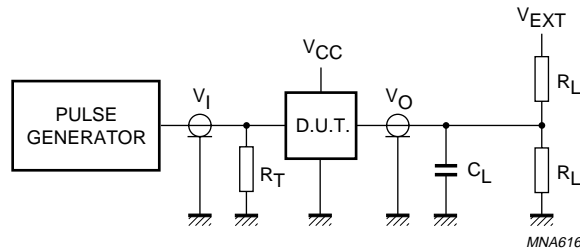

V _{CC}	V _I	C _L	R _L	V _{EXT}		
				t _{PLH} /t _{PHL}	t _{PZH} /t _{PHZ}	t _{PZL} /t _{PLZ}
1.65 to 1.95 V	V _{CC}	30 pF	1 kΩ	open	GND	2V _{CC}
2.3 to 2.7 V	V _{CC}	30 pF	500 Ω	open	GND	2V _{CC}
2.7 and 3.0 to 3.6 V	2.7 V	50 pF	500 Ω	open	GND	6 V
4.5 to 5.5 V	V _{CC}	50 pF	500 Ω	open	GND	2V _{CC}

Definitions for test circuits:

R_L = Load resistor.

C_L = Load capacitance including jig and probe capacitance.

R_T = Termination resistance should be equal to the output impedance Z_o of the pulse generator.

Fig.16 Load circuitry for switching times.

ADDITIONAL AC CHARACTERISTICS

Recommended conditions and typical values at T_{amb} = 25 °C.

SYMBOL	PARAMETER	TEST CONDITIONS	V _{CC} (V)	TYPICAL	UNIT
d _{sin}	sine-wave distortion	R _L = 10 kΩ; C _L = 50 pF; f _{in} = 1 kHz; see Fig.18	1.65	0.032	%
			2.3	0.008	%
			3	0.006	%
			4.5	0.005	%
		R _L = 10 kΩ; C _L = 50 pF; f _{in} = 10 kHz; see Fig.18	1.65	0.068	%
			2.3	0.009	%
			3	0.008	%
			4.5	0.006	%
f _{ON}	switch ON signal frequency response	R _L = 600 Ω; C _L = 50 pF; see Fig.17; note 1	1.65	170	MHz
			2.3	210	MHz
			3	212	MHz
			4.5	215	MHz
		R _L = 50 Ω; C _L = 5 pF; see Fig.17; note 1	1.65	> 500	MHz
			2.3	> 500	MHz
			3	> 500	MHz
			4.5	> 500	MHz

Quad bilateral switches

74LVC4066

SYMBOL	PARAMETER	TEST CONDITIONS	V _{CC} (V)	TYPICAL	UNIT
$\alpha_{OFF(Feedthru)}$	switch OFF signal feed-through attenuation	$R_L = 600 \Omega; C_L = 50 \text{ pF}; f_{in} = 1 \text{ MHz};$ see Fig.19; note 2	1.65	-46	dB
			2.3	-46	dB
			3	-46	dB
			4.5	-46	dB
		$R_L = 50 \Omega; C_L = 5 \text{ pF}; f_{in} = 1 \text{ MHz};$ see Fig.19; note 2	1.65	-42	dB
			2.3	-42	dB
			3	-42	dB
			4.5	-42	dB
$\alpha_{ct(E-Y/Z)}$	crosstalk between control input to signal output	$R_L = 600 \Omega; C_L = 50 \text{ pF}; f_{in} = 1 \text{ MHz}; t_r = t_f = 2 \text{ ns};$ see Fig.20	1.65	69	mV
			2.3	87	mV
			3	156	mV
			4.5	302	mV
$\alpha_{ct(S)}$	crosstalk between switches)	$R_L = 600 \Omega; C_L = 50 \text{ pF}; f_{in} = 1 \text{ MHz};$ see Fig.21	1.65	-58	dB
			2.3	-58	dB
			3	-58	dB
			4.5	-58	dB
		$R_L = 50 \Omega; C_L = 5 \text{ pF}; f_{in} = 1 \text{ MHz};$ see Fig.21	1.65	-58	dB
			2.3	-58	dB
			3	-58	dB
			4.5	-58	dB
C_{PD}	power dissipation capacitance	$f_{in} = 10 \text{ MHz}$	2.5	11.0	pF
			3.3	12.5	pF
			5.0	15.6	pF
Q	charge injection	$C_L = 0.1 \text{ nF}; V_{gen} = 0 \text{ V}; R_{gen} = 0 \Omega;$ $f = 1 \text{ MHz}; R_L = 1 \text{ M}\Omega;$ see Fig.22; note 3	3.3	0.8	pC
			5.5	1.2	pC

Notes

1. Adjust f_{in} voltage to obtain 0 dBm level at output. Increase f_{in} frequency until dB meter reads -3 dB.
2. Adjust f_{in} voltage to obtain 0 dBm level at input.
3. Guaranteed by design.

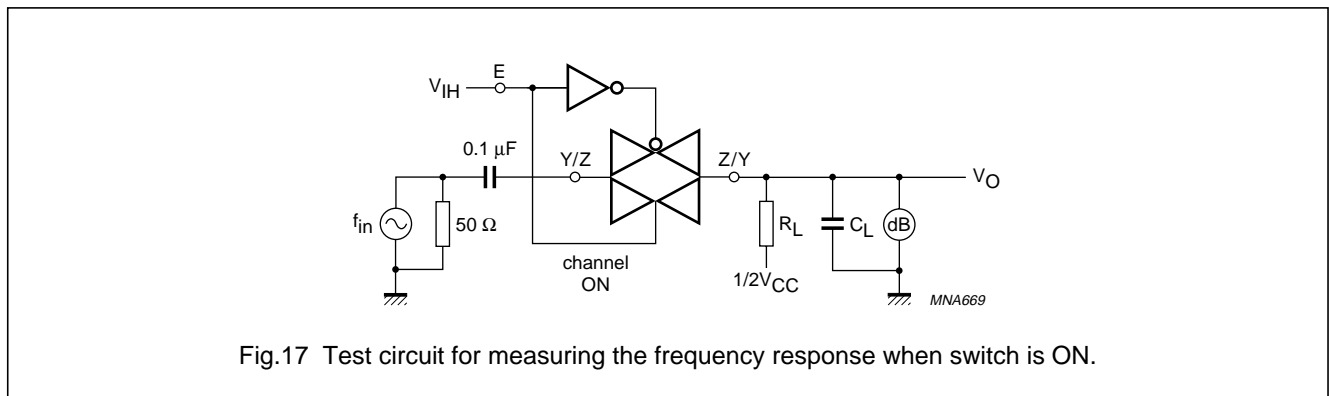

Quad bilateral switches

74LVC4066

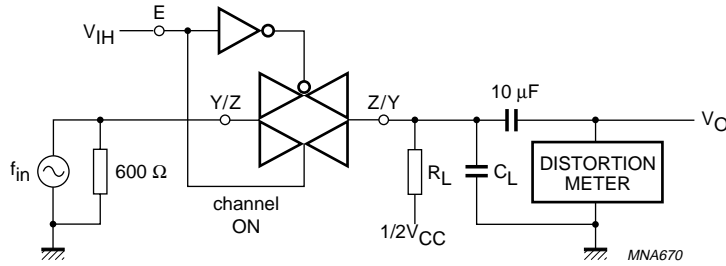

V _{CC}	V _{IH}
1.65 V	1.4 V (p-p)
2.3 V	2 V (p-p)
3 V	2.5 V (p-p)
4. V	4 V (p-p)

Fig.18 Test circuit for measuring sine-wave distortion.

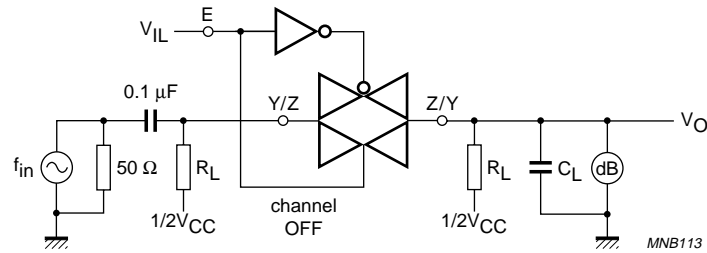

Fig.19 Test circuit for measuring feed-through when switch is OFF.

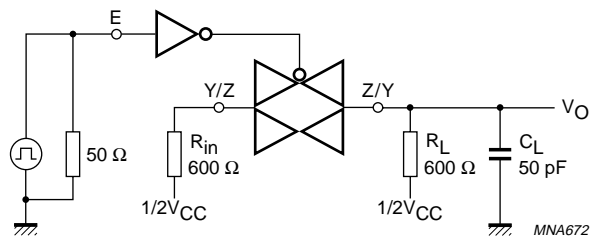

Fig.20 Crosstalk between control input to signal output.

Quad bilateral switches

74LVC4066

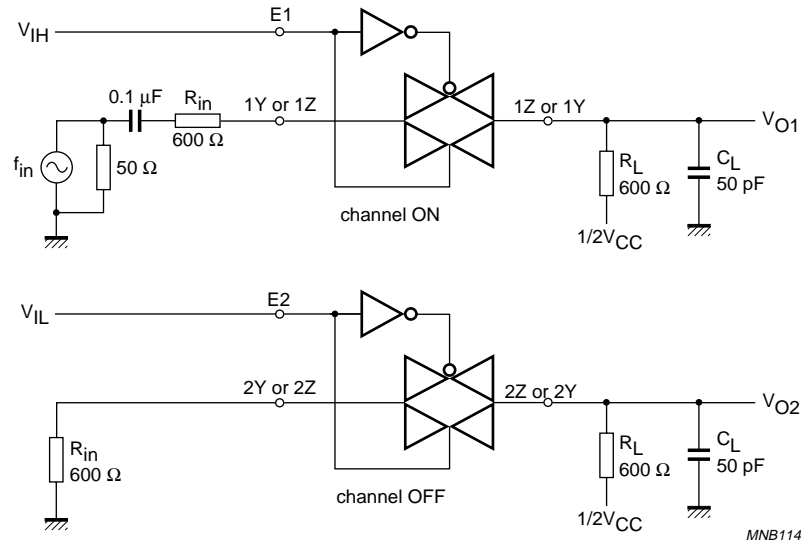
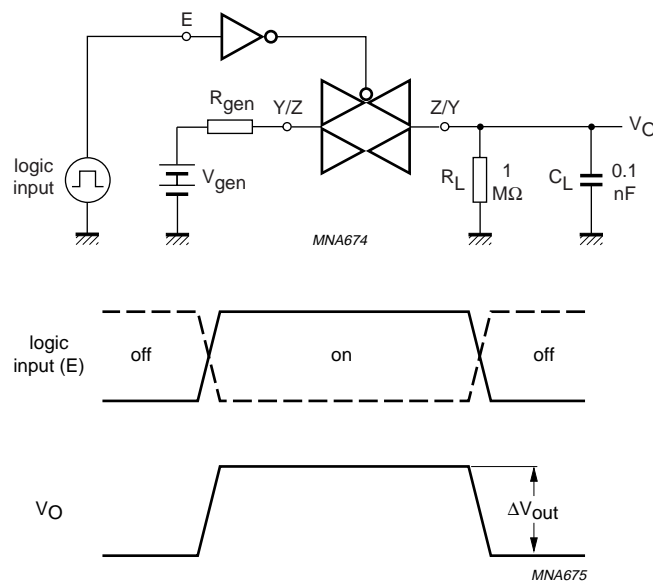

Fig.21 Crosstalk between switches.



$$Q = \Delta V_{out} \times C_L$$

Fig.22 Charge injection test.

Quad bilateral switches

74LVC4066

PACKAGE OUTLINES

SO14: plastic small outline package; 14 leads; body width 3.9 mm; body thickness 1.47 mm

SOT108-2

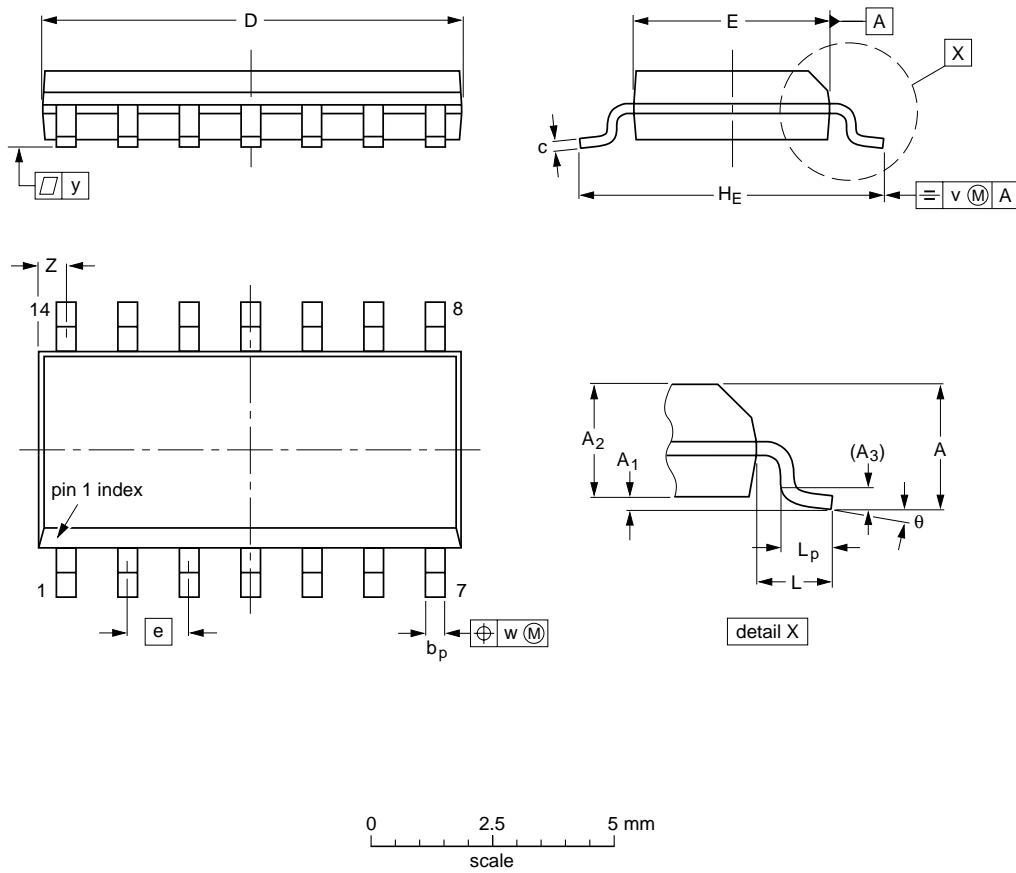

DIMENSIONS (inch dimensions are derived from the original mm dimensions)

UNIT	A max.	A ₁	A ₂	A ₃	b _p	c	D ⁽¹⁾	E ⁽¹⁾	e	H _E	L	L _p	v	w	y	Z ⁽¹⁾	θ
mm	1.75	0.25 0.10	1.55 1.40	0.25	0.49 0.36	0.25 0.19	8.75 8.55	4.0 3.8	1.27	6.2 5.8	1.05	1.0 0.4	0.25	0.25	0.1	0.7 0.3	8° 0°
inches	0.069	0.010 0.004	0.061 0.055	0.01	0.019 0.014	0.0100 0.0075	0.35 0.34	0.16 0.15	0.05	0.244 0.228	0.041	0.039 0.016	0.01	0.01	0.004	0.028 0.012	

Note

1. Plastic or metal protrusions of 0.15 mm (0.006 inch) maximum per side are not included.

OUTLINE VERSION	REFERENCES				EUROPEAN PROJECTION	ISSUE DATE
	IEC	JEDEC	JEITA			
SOT108-2		MS-012				01-05-29 03-02-19

Quad bilateral switches

74LVC4066

TSSOP14: plastic thin shrink small outline package; 14 leads; body width 4.4 mm

SOT402-1

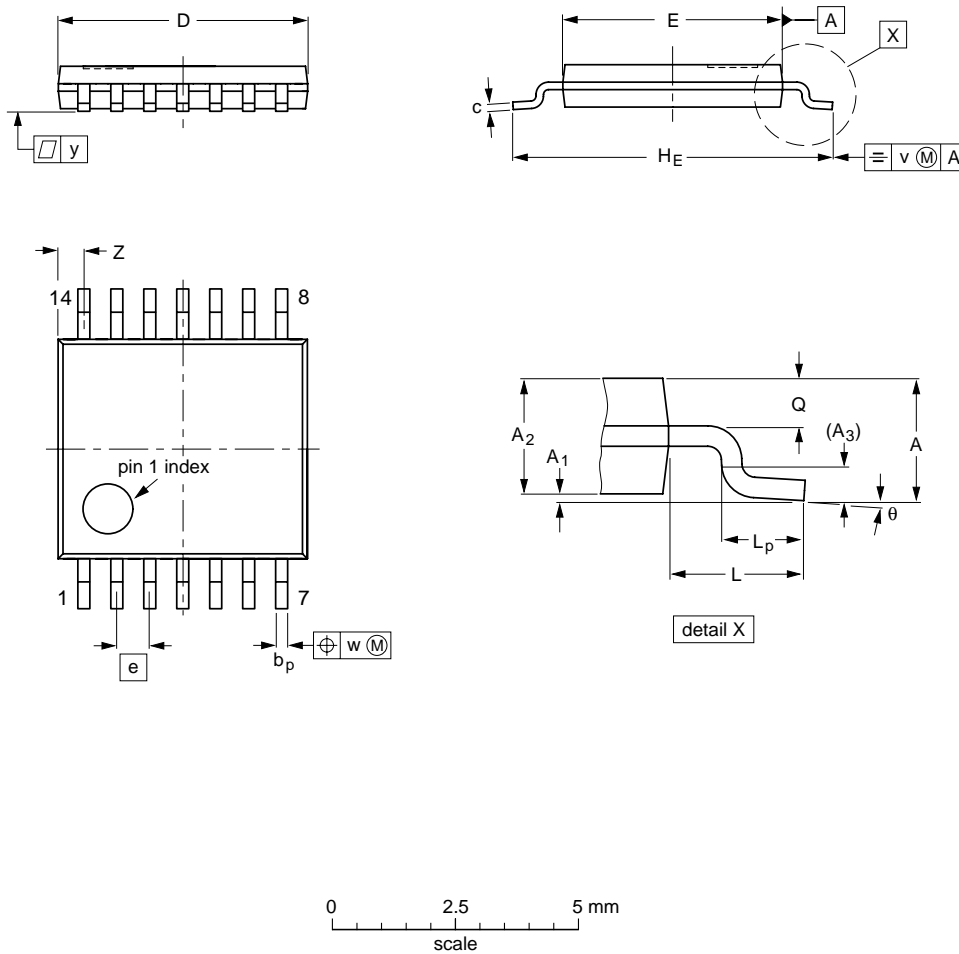

DIMENSIONS (mm are the original dimensions)

UNIT	A max.	A ₁	A ₂	A ₃	b _p	c	D ⁽¹⁾	E ⁽²⁾	e	H _E	L	L _p	Q	v	w	y	z ⁽¹⁾	θ
mm	1.1	0.15 0.05	0.95 0.80	0.25	0.30 0.19	0.2 0.1	5.1 4.9	4.5 4.3	0.65	6.6 6.2	1	0.75 0.50	0.4 0.3	0.2	0.13	0.1	0.72 0.38	8° 0°

Notes

1. Plastic or metal protrusions of 0.15 mm maximum per side are not included.
2. Plastic interlead protrusions of 0.25 mm maximum per side are not included.

OUTLINE VERSION	REFERENCES				EUROPEAN PROJECTION	ISSUE DATE
	IEC	JEDEC	JEITA			
SOT402-1		MO-153				99-12-27 03-02-18

Quad bilateral switches

74LVC4066

DHVQFN14: plastic dual in-line compatible thermal enhanced very thin quad flat package; no leads; 14 terminals; body 2.5 x 3 x 0.85 mm

SOT762-1

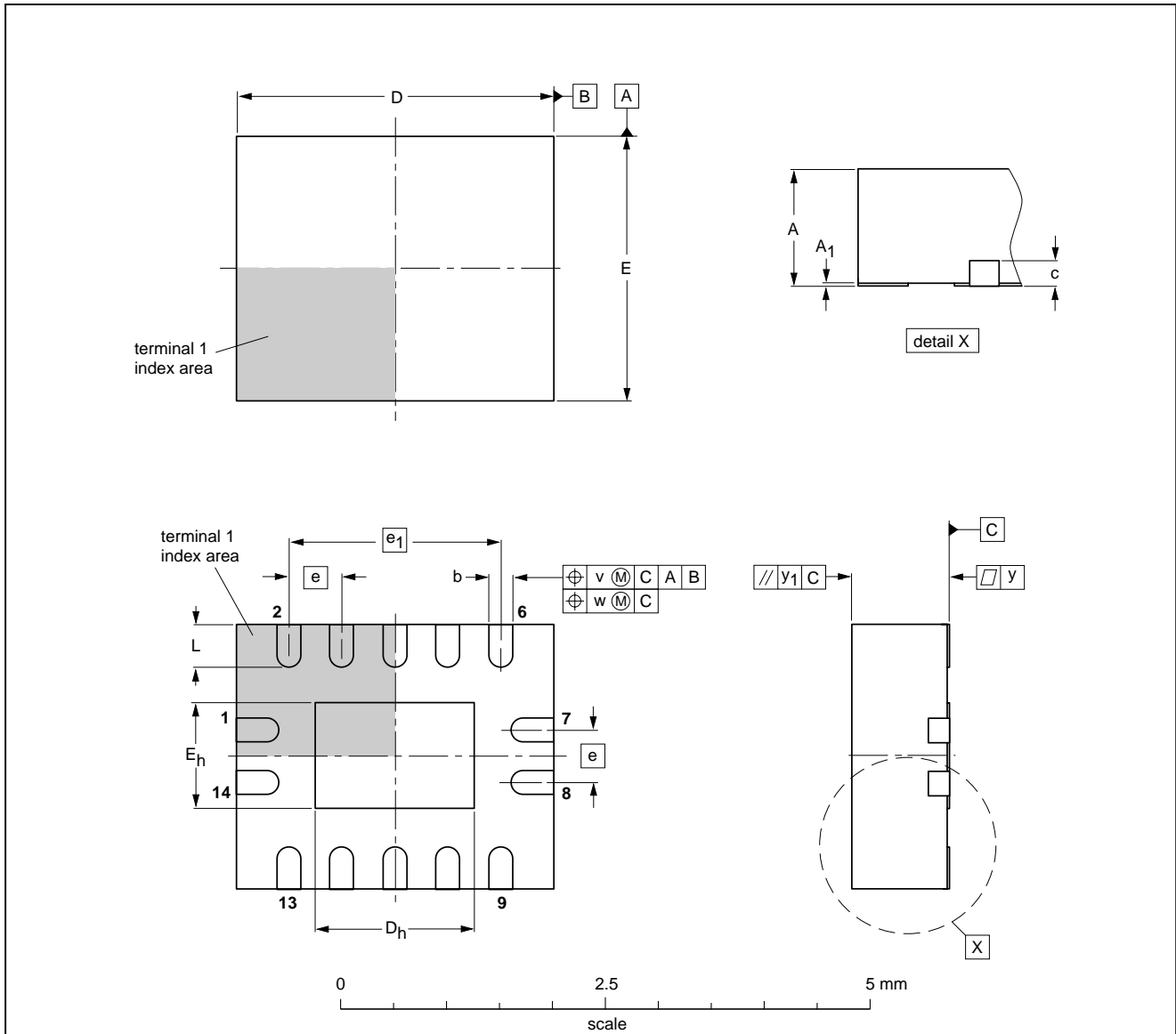

DIMENSIONS (mm are the original dimensions)

UNIT	A ⁽¹⁾ max.	A ₁	b	c	D ⁽¹⁾	D _h	E ⁽¹⁾	E _h	e	e ₁	L	v	w	y	y ₁
mm	1	0.05 0.00	0.30 0.18	0.2	3.1 2.9	1.65 1.35	2.6 2.4	1.15 0.85	0.5	2	0.5 0.3	0.1	0.05	0.05	0.1

Note

1. Plastic or metal protrusions of 0.075 mm maximum per side are not included.

OUTLINE VERSION	REFERENCES			EUROPEAN PROJECTION	ISSUE DATE
	IEC	JEDEC	JEITA		
SOT762-1	---	MO-241	---		02-10-17 03-01-27

Quad bilateral switches

74LVC4066

DATA SHEET STATUS

LEVEL	DATA SHEET STATUS ⁽¹⁾	PRODUCT STATUS ⁽²⁾⁽³⁾	DEFINITION
I	Objective data	Development	This data sheet contains data from the objective specification for product development. Philips Semiconductors reserves the right to change the specification in any manner without notice.
II	Preliminary data	Qualification	This data sheet contains data from the preliminary specification. Supplementary data will be published at a later date. Philips Semiconductors reserves the right to change the specification without notice, in order to improve the design and supply the best possible product.
III	Product data	Production	This data sheet contains data from the product specification. Philips Semiconductors reserves the right to make changes at any time in order to improve the design, manufacturing and supply. Relevant changes will be communicated via a Customer Product/Process Change Notification (CPCN).

Notes

1. Please consult the most recently issued data sheet before initiating or completing a design.
2. The product status of the device(s) described in this data sheet may have changed since this data sheet was published. The latest information is available on the Internet at URL <http://www.semiconductors.philips.com>.
3. For data sheets describing multiple type numbers, the highest-level product status determines the data sheet status.

DEFINITIONS

Short-form specification — The data in a short-form specification is extracted from a full data sheet with the same type number and title. For detailed information see the relevant data sheet or data handbook.

Limiting values definition — Limiting values given are in accordance with the Absolute Maximum Rating System (IEC 60134). Stress above one or more of the limiting values may cause permanent damage to the device. These are stress ratings only and operation of the device at these or at any other conditions above those given in the Characteristics sections of the specification is not implied. Exposure to limiting values for extended periods may affect device reliability.

Application information — Applications that are described herein for any of these products are for illustrative purposes only. Philips Semiconductors make no representation or warranty that such applications will be suitable for the specified use without further testing or modification.

DISCLAIMERS

Life support applications — These products are not designed for use in life support appliances, devices, or systems where malfunction of these products can reasonably be expected to result in personal injury. Philips Semiconductors customers using or selling these products for use in such applications do so at their own risk and agree to fully indemnify Philips Semiconductors for any damages resulting from such application.

Right to make changes — Philips Semiconductors reserves the right to make changes in the products - including circuits, standard cells, and/or software - described or contained herein in order to improve design and/or performance. When the product is in full production (status 'Production'), relevant changes will be communicated via a Customer Product/Process Change Notification (CPCN). Philips Semiconductors assumes no responsibility or liability for the use of any of these products, conveys no licence or title under any patent, copyright, or mask work right to these products, and makes no representations or warranties that these products are free from patent, copyright, or mask work right infringement, unless otherwise specified.

Philips Semiconductors – a worldwide company

Contact information

For additional information please visit <http://www.semiconductors.philips.com>. Fax: +31 40 27 24825

For sales offices addresses send e-mail to: sales.addresses@www.semiconductors.philips.com.

© Koninklijke Philips Electronics N.V. 2003

SCA75

All rights are reserved. Reproduction in whole or in part is prohibited without the prior written consent of the copyright owner.

The information presented in this document does not form part of any quotation or contract, is believed to be accurate and reliable and may be changed without notice. No liability will be accepted by the publisher for any consequence of its use. Publication thereof does not convey nor imply any license under patent- or other industrial or intellectual property rights.

Printed in The Netherlands

613508/01/pp23

Date of release: 2003 Aug 12

Document order number: 9397 750 11652

Let's make things better.

**Philips
Semiconductors**



PHILIPS

Copyright © Each Manufacturing Company.

All Datasheets cannot be modified without permission.

This datasheet has been download from :

www.AllDataSheet.com

100% Free DataSheet Search Site.

Free Download.

No Register.

Fast Search System.

www.AllDataSheet.com