



Burr-Brown Products
from Texas Instruments

捷多邦, 专业PCB打样工厂, 24小时加急出货

VCA2619



SBOS276A – AUGUST 2003 – REVISED AUGUST 2003

Dual, Variable Gain Amplifier with Input Buffer

FEATURES

- GAIN RANGE: 50dB
- LOW CROSSTALK: -60dB at Max Gain, $f_{\text{IN}} = 5\text{MHz}$
- HIGH-SPEED VARIABLE GAIN ADJUST
- POWER SHUTDOWN MODE
- HIGH IMPEDANCE INPUT BUFFER

APPLICATIONS

- ULTRASOUND SYSTEMS
- WIRELESS RECEIVERS
- TEST EQUIPMENT
- RADAR

DESCRIPTION

The VCA2619 is a highly integrated, dual receive channel, Variable Gain Amplifier (VGA) with analog gain control.

The VCA2619's VGA section consists of two parts: the Voltage Controlled Attenuator (VCA) and the Programmable Gain Amplifier (PGA). The gain and gain range of the PGA can be digitally programmed. The combination of these two programmable elements results in a variable gain ranging from 0dB up to a maximum gain as defined by the user through external connections. The single-ended unity gain input buffer provides predictable high input impedance. The output of the VGA can be used in either a single-ended or differential mode to drive high-performance Analog-to-Digital (A/D) converters. A separate power-down pin reduces power consumption.

The VCA2619 also features low crosstalk and outstanding distortion performance. The combination of low noise and gain range programmability make the VCA2619 a versatile building block in a number of applications where noise performance is critical. The VCA2619 is available in a TQFP-32 package.

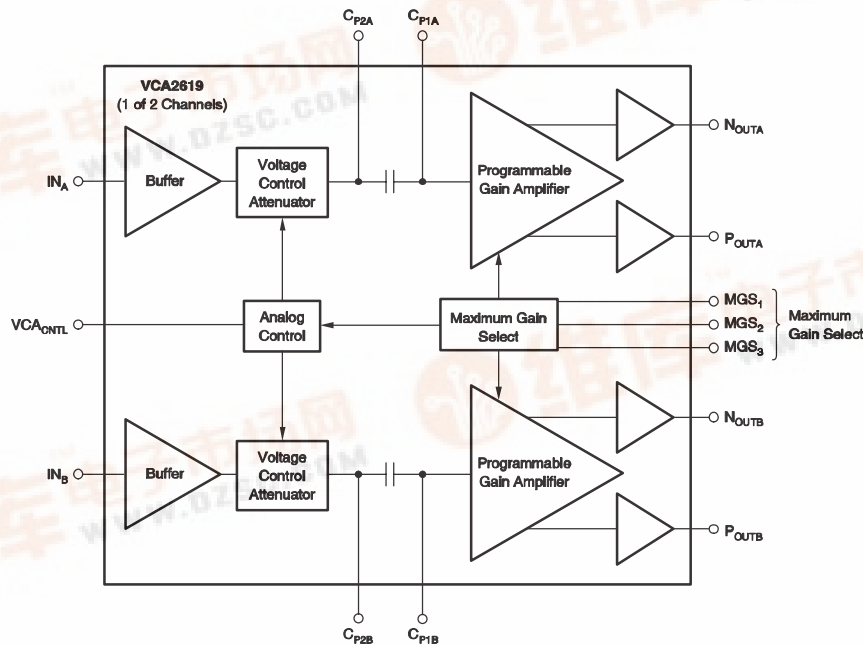

Please be aware that an important notice concerning availability, standard warranty, and use in critical applications of Texas Instruments semiconductor products and disclaimers thereto appears at the end of this data sheet.

All trademarks are the property of their respective owners.

PRODUCTION DATA information is current as of publication date. Products

Copyright © 2003, Texas Instruments Incorporated

ABSOLUTE MAXIMUM RATINGS(1)

Power Supply (+V _S)	+6V
Analog Input	-0.3V to (+V _S + 0.3V)
Logic Input	-0.3V to (+V _S + 0.3V)
Case Temperature	+100°C
Junction Temperature	+150°C
Storage Temperature	-40°C to +150°C

(1) Stresses above those listed under “Absolute Maximum Ratings” may cause permanent damage to the device. Exposure to absolute maximum conditions for extended periods may affect device reliability.



This integrated circuit can be damaged by ESD. Texas Instruments recommends that all integrated circuits be handled with appropriate precautions. Failure to observe proper handling and installation procedures can cause damage.

ESD damage can range from subtle performance degradation to complete device failure. Precision integrated circuits may be more susceptible to damage because very small parametric changes could cause the device not to meet its published specifications.

PACKAGE/ORDERING INFORMATION

PRODUCT	PACKAGE-LEAD	PACKAGE DESIGNATOR(1)	SPECIFIED TEMPERATURE RANGE	PACKAGE MARKING	ORDERING NUMBER	TRANSPORT MEDIA, QUANTITY
VCA2619Y	TQFP-32	PBS	-40°C to +85°C	VCA2619Y	VCA2619YT	Tape and Reel, 250
					VCA2619YR	Tape and Reel, 2000

(1) For the most current specification and package information, refer to our web site at www.ti.com.

ELECTRICAL CHARACTERISTICS

 At $T_A = +25^\circ\text{C}$, $V_{DD} = 5\text{V}$, load resistance = 500Ω on each output to ground single-ended output (1Vpp), $MGS = 111$, $V_{CA_{CNTL}} = 2.9\text{V}$ and $f_{IN} = 5\text{MHz}$, unless otherwise noted.

PARAMETER	CONDITIONS	VCA2619			UNIT
		MIN	TYP	MAX	
BUFFER					
Input Resistance			600		$k\Omega$
Input Capacitance			5		pF
Input Bias Current			1		nA
Maximum Input Voltage			1		Vpp
Input Voltage Noise	PGA Gain = 45dB, $R_S = 50\Omega$		5.9		$nV/\sqrt{\text{Hz}}$
Input Current Noise	Independent of Gain		350		$fA/\sqrt{\text{Hz}}$
Noise Figure	$R_F = 550\Omega$, PGA Gain = 45dB, $R_S = 75\Omega$		13		dB
Bandwidth			100		MHz
PROGRAMMABLE VARIABLE GAIN AMPLIFIER					
Peak Input Voltage			1		Vpp
-3dB Bandwidth			20		MHz
Slew Rate			300		V/ μs
Output Signal Range	$R_L \geq 500\Omega$ Each Side to Ground		2.5 \pm 1		V
Output Impedance			1		Ω
Output Short-Circuit Current			± 40		mA
3rd-Harmonic Distortion	$V_{OUT} = 1\text{Vpp}$, $V_{CA_{CNTL}} = 2.9\text{V}$	-45	-60		dBc
2nd-Harmonic Distortion	$V_{OUT} = 1\text{Vpp}$, $V_{CA_{CNTL}} = 2.9\text{V}$	-42	-50		dBc
2nd-Harmonic Distortion	Differential, $V_{OUT} = 2\text{Vpp}$, $V_{CA_{CNTL}} = 3.0\text{V}$, $MGS = 011$		-50		dBc
Overload Performance (2nd-Harmonic Distortion)	Input Signal = 0.5Vpp, $V_{CA_{CNTL}} = 2\text{V}$		-40 to -45		dB
Time Delay			5		ns
IMD, 2-Tone	$V_{OUT} = 2\text{Vpp}$, $f = 9.95\text{MHz}$		-59		dBc
Crosstalk	2Vpp Differential		-60		dB
ACCURACY					
Gain Slope	$V_{CA_{CNTL}} = 0.4\text{V}$ to 2.9V		20		dB/V
Gain Error ⁽¹⁾	$V_{CA_{CNTL}} = 0.2\text{V}$ to 3.0V		± 2.75		dB
	$V_{CA_{CNTL}} = 0.4\text{V}$ to 2.9V		± 1.50	± 2.0	dB
Output Offset Voltage			± 50		mV
Gain Range	$V_{CA_{CNTL}} = 0.2\text{V}$ to 3.0V		52		dB
	$V_{CA_{CNTL}} = 0.4\text{V}$ to 2.9V	48	50		dB
GAIN CONTROL INTERFACE					
Input Voltage ($V_{CA_{CNTL}}$) Range			0 to 3.0		V
Input Resistance			1		$M\Omega$
Response Time	45dB Gain Change		0.2		μs
POWER SUPPLY					
Specified Operating Range		4.75	5.0	5.25	V
Power Dissipation			240	300	mW
Power-Down			9.2		mW

(1) Referenced to best fit dB-linear curve.

PIN CONFIGURATION

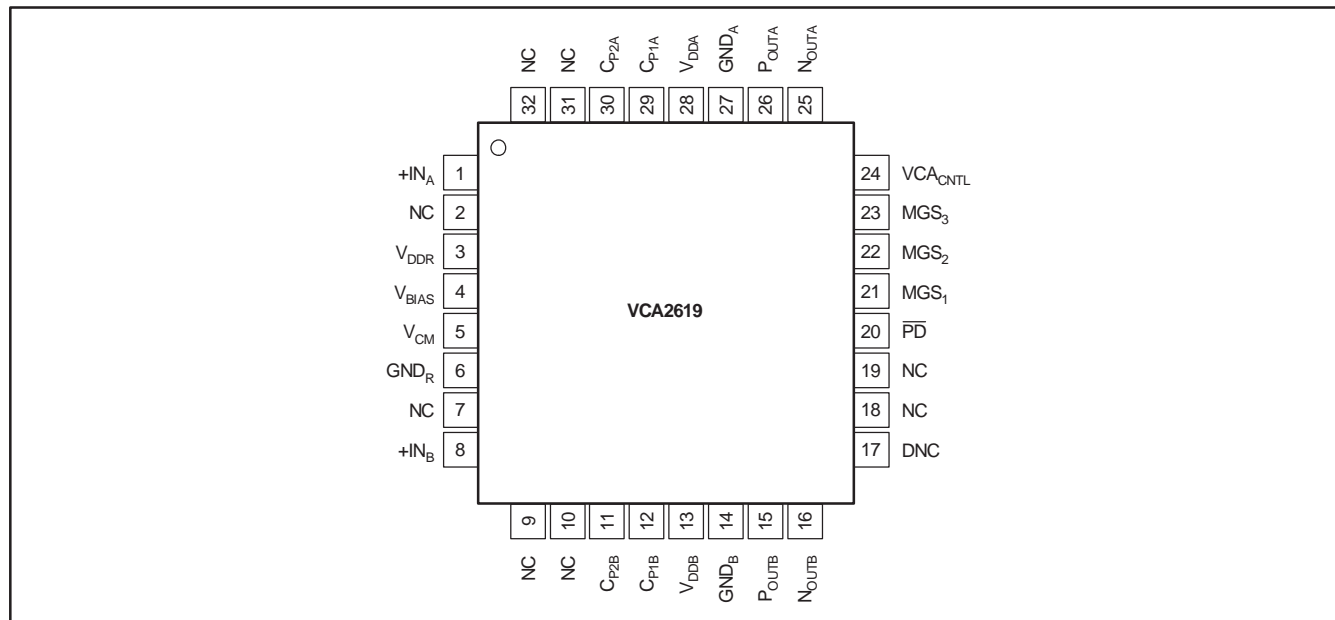

PIN CONFIGURATION

PIN	DESIGNATOR	DESCRIPTION	PIN	DESIGNATOR	DESCRIPTION
1	+IN _A	Noninverting Input Channel A	17	DNC	Do Not Connect
2	NC	No Internal Connection	18	NC	No Internal Connection
3	V _{DDR}	Internal Reference Supply	19	NC	No Internal Connection
4	V _{BIAS}	Bias Voltage	20	PD	Power-Down (Active LOW)
5	V _{CM}	Common-Mode Voltage	23	MGS ₁	Maximum Gain Select 1 (MSB)
6	GND _R	Internal Reference Ground	22	MGS ₂	Maximum Gain Select 2
7	NC	No Internal Connection	23	MGS ₃	Maximum Gain Select 3 (LSB)
8	+IN _B	Noninverting Input Channel B	24	VCA _{CNTL}	VCA Analog Control
9	NC	No Internal Connection	25	N _{OUTA}	Negative VCA Output Channel A
10	NC	No Internal Connection	26	P _{OUTA}	Positive VCA Output Channel A
11	C _{P2B}	Coupling Capacitor Channel B	27	GND _A	Ground Channel A
12	C _{P1B}	Coupling Capacitor Channel B	28	V _{DDA}	+5V Supply Channel A
13	V _{DDB}	+5V Supply Channel B	29	C _{P1A}	Coupling Capacitor Channel A
14	GND _B	Ground Channel B	30	C _{P2A}	Coupling Capacitor Channel A
15	P _{OUTB}	Positive Output Channel B	31	NC	No Internal Connection
16	N _{OUTB}	Negative Output Channel B	32	NC	No Internal Connection

TYPICAL CHARACTERISTICS

At $T_A = 25^\circ\text{C}$ and $V_{DD} = 5\text{V}$, load resistance = 500Ω on each output to ground, differential output ($2V_{PP}$) MGS = 111, and $f_{IN} = 5\text{MHz}$, unless otherwise noted.

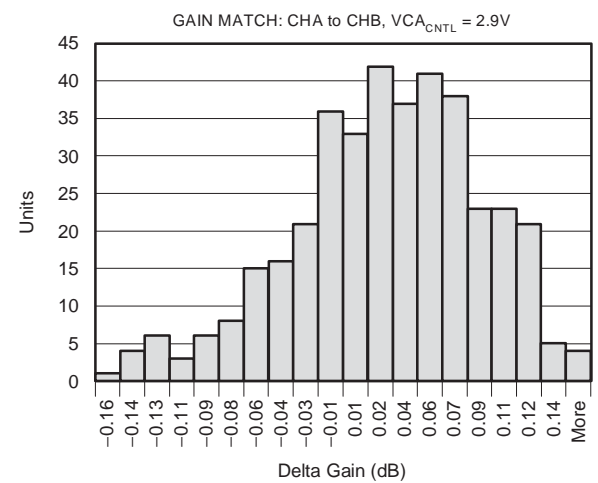
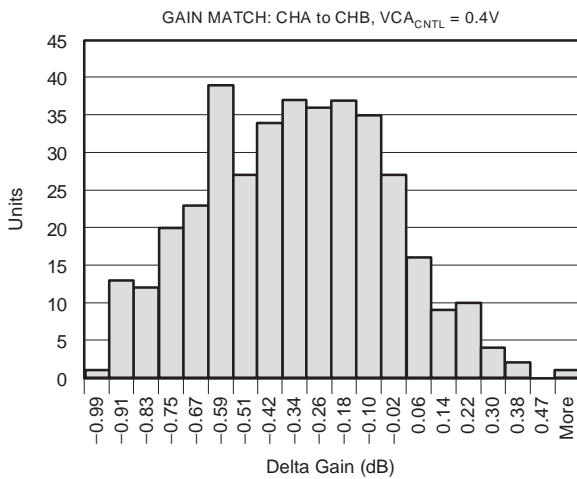
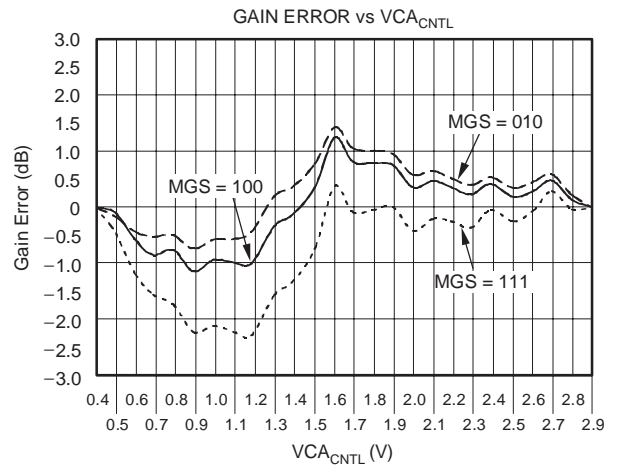
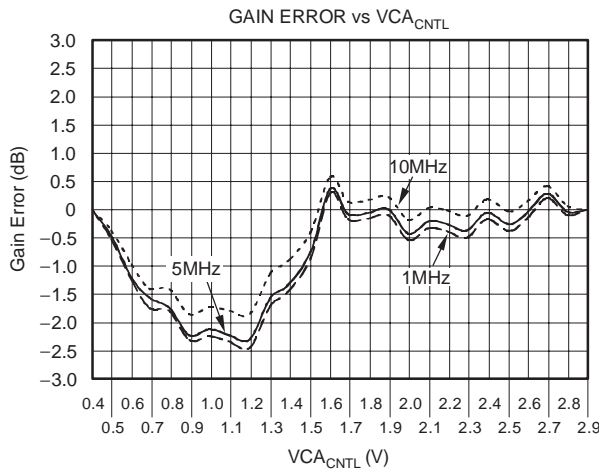
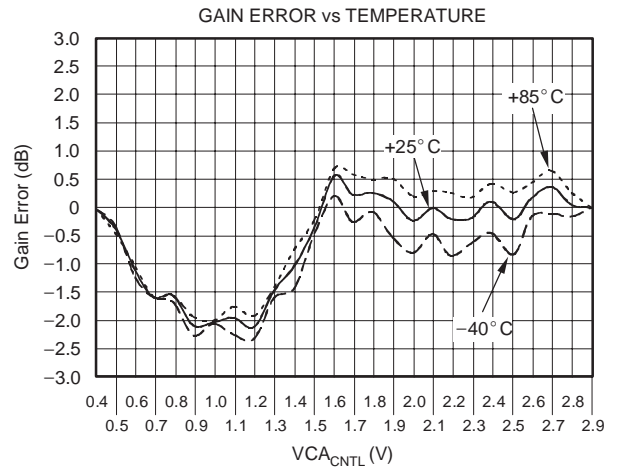
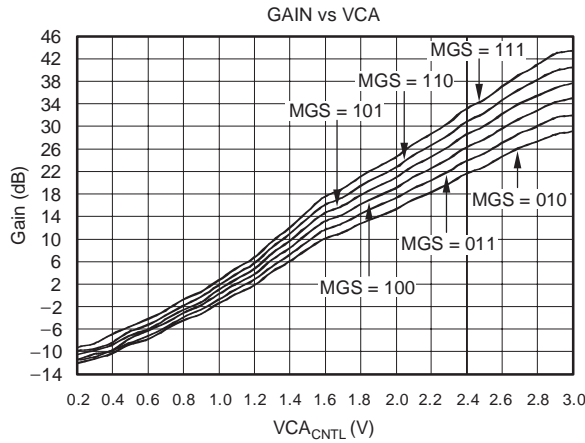

TYPICAL CHARACTERISTICS (continued)

At $T_A = 25^\circ\text{C}$ and $V_{DD} = 5\text{V}$, load resistance = 500Ω on each output to ground, differential output ($2V_{PP}$) $MGS = 111$, and $f_{IN} = 5\text{MHz}$, unless otherwise noted.

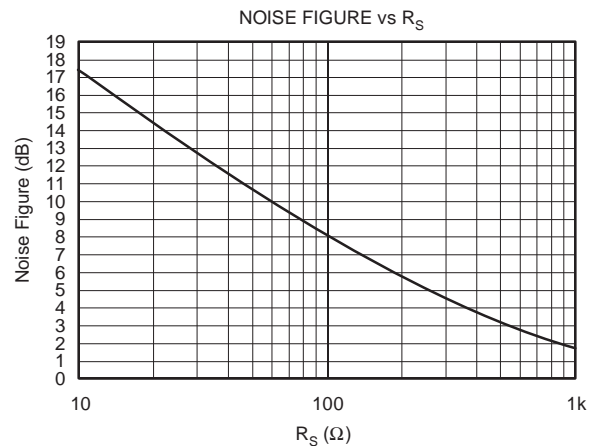
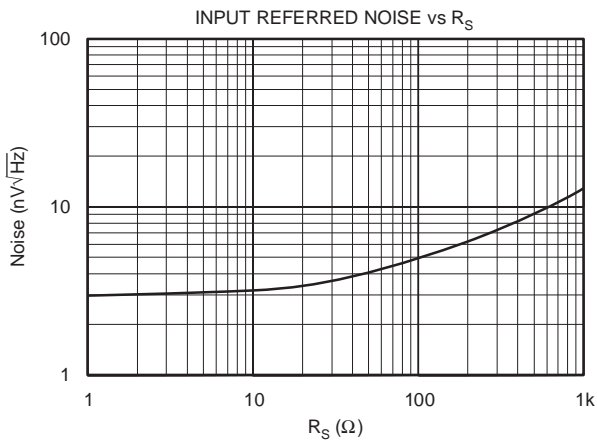
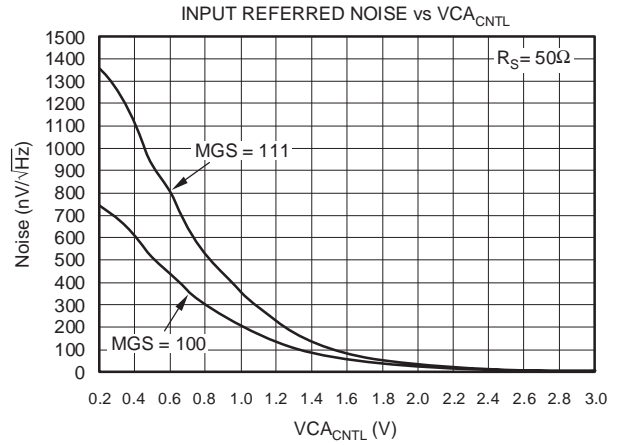
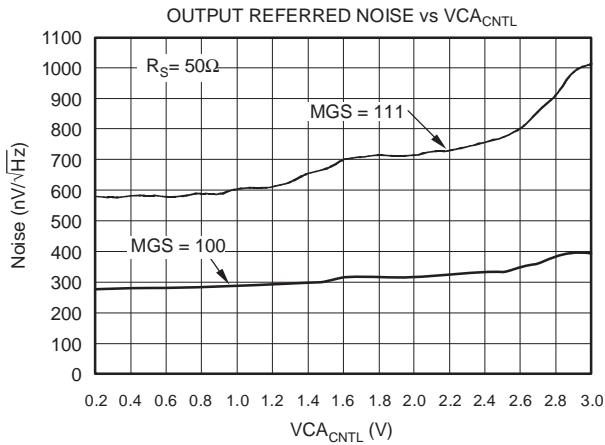
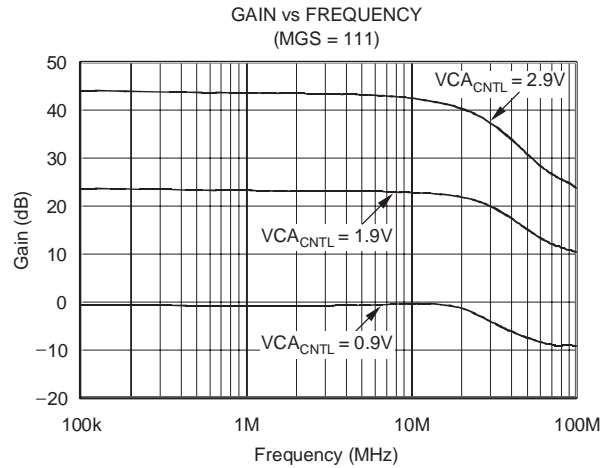
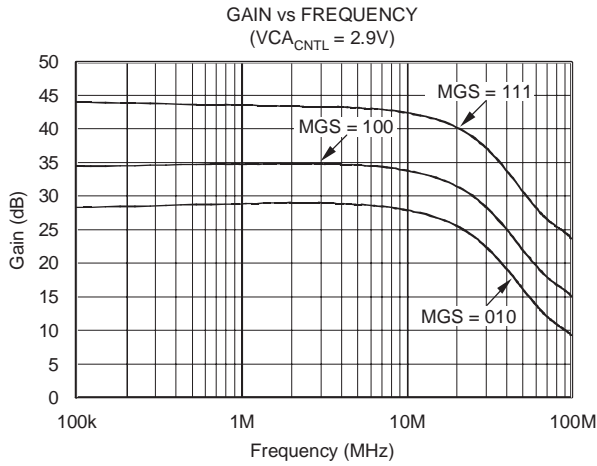

TYPICAL CHARACTERISTICS (continued)

At $T_A = 25^\circ\text{C}$ and $V_{DD} = 5\text{V}$, load resistance = 500Ω on each output to ground, differential output ($2V_{pp}$) $\text{MGS} = 111$, and $f_{IN} = 5\text{MHz}$, unless otherwise noted.

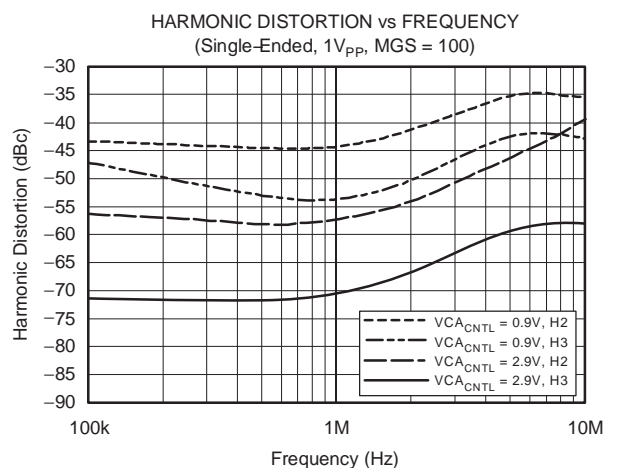
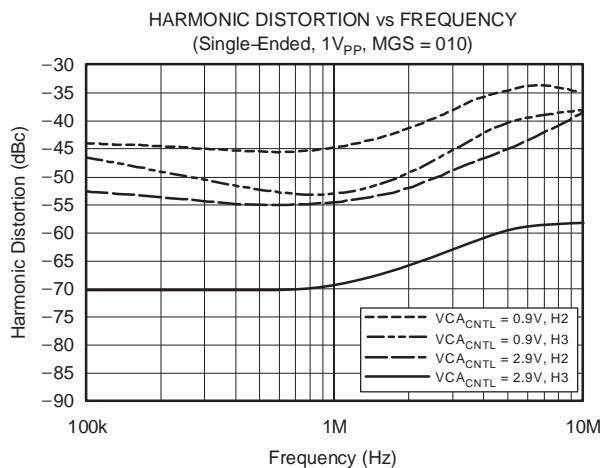
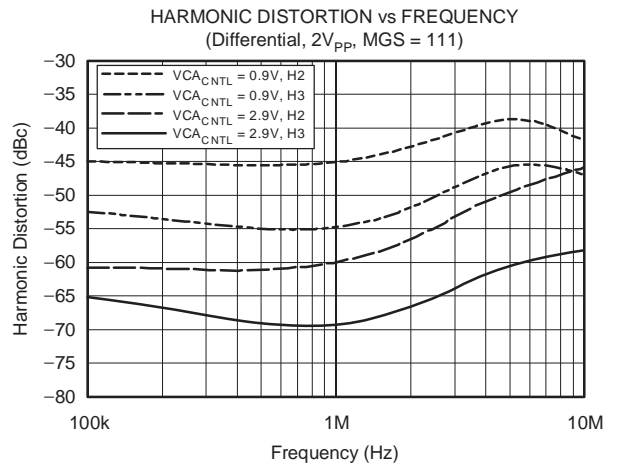
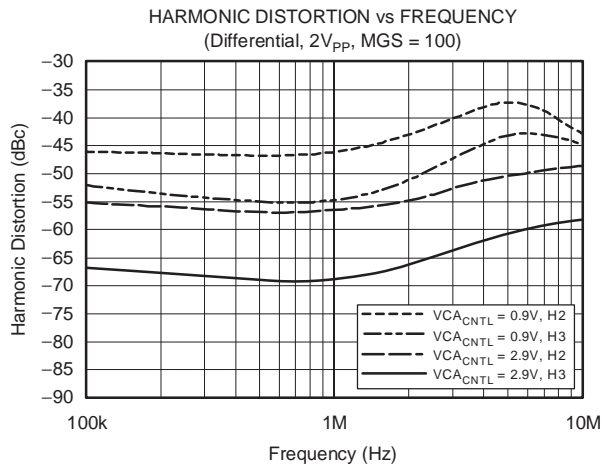
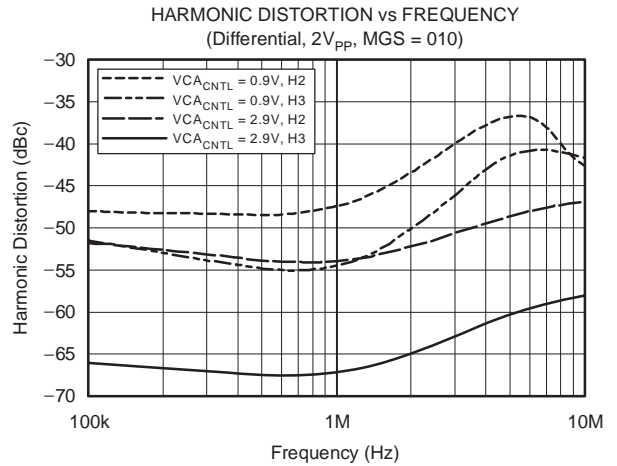
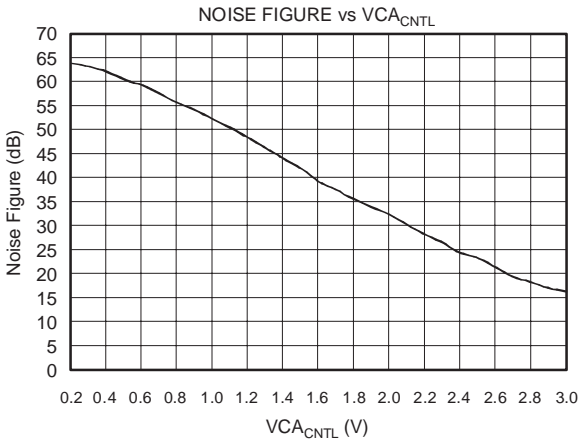

TYPICAL CHARACTERISTICS (continued)

At $T_A = 25^\circ\text{C}$ and $V_{DD} = 5\text{V}$, load resistance = 500Ω on each output to ground, differential output ($2V_{PP}$) MGS = 111, and $f_{IN} = 5\text{MHz}$, unless otherwise noted.

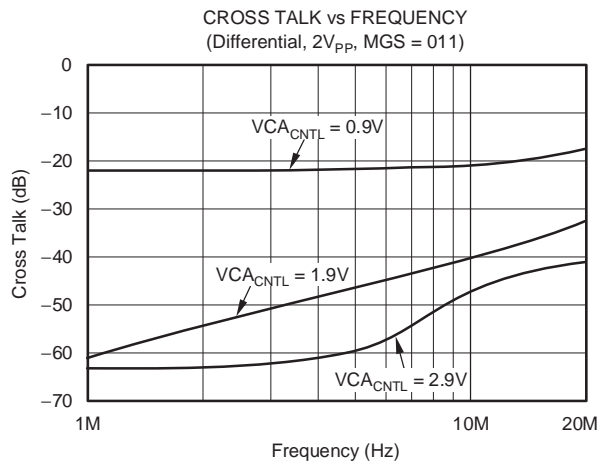
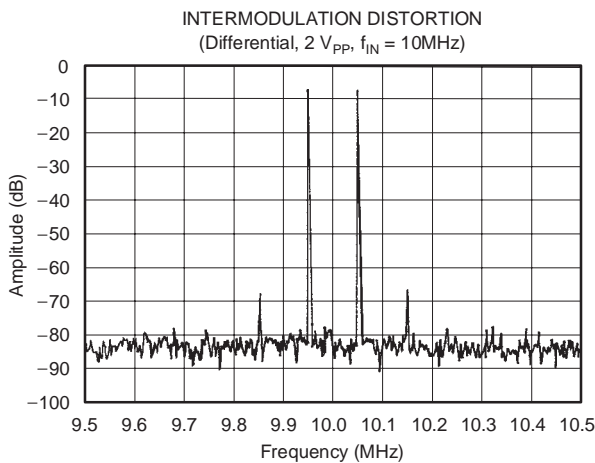
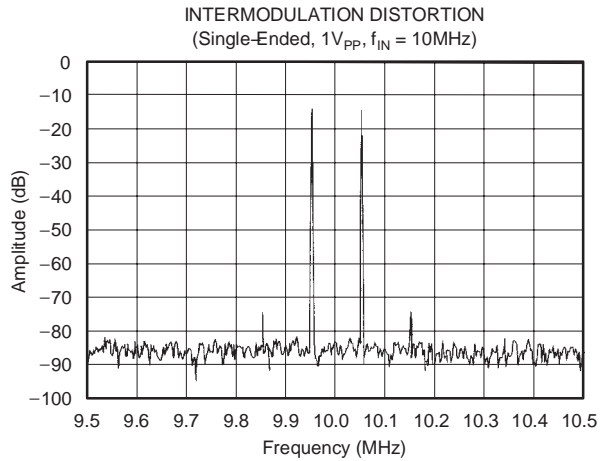
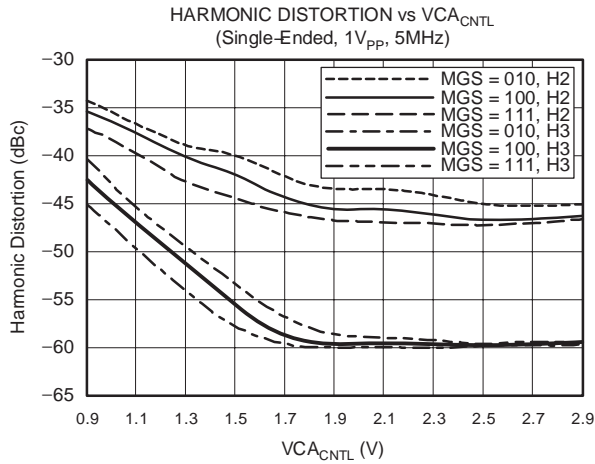
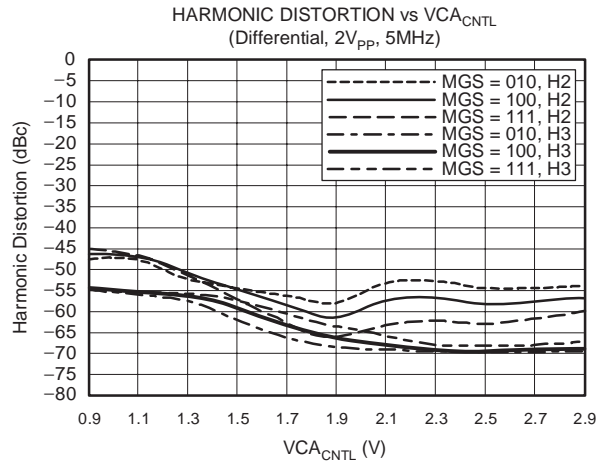
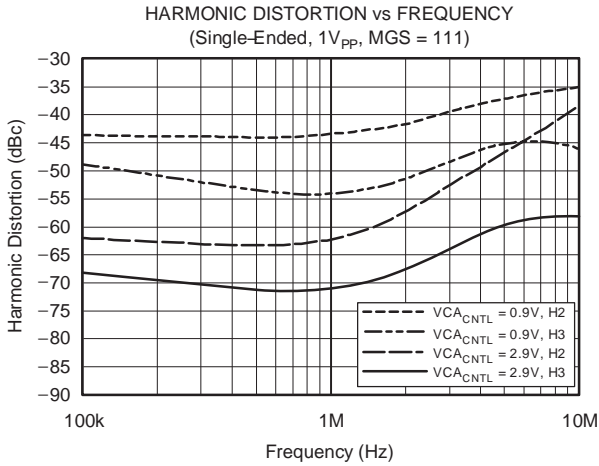

TYPICAL CHARACTERISTICS (continued)

At $T_A = 25^\circ\text{C}$ and $V_{DD} = 5\text{V}$, load resistance = 500Ω on each output to ground, differential output ($2V_{PP}$) $MGS = 111$, and $f_{IN} = 5\text{MHz}$, unless otherwise noted.

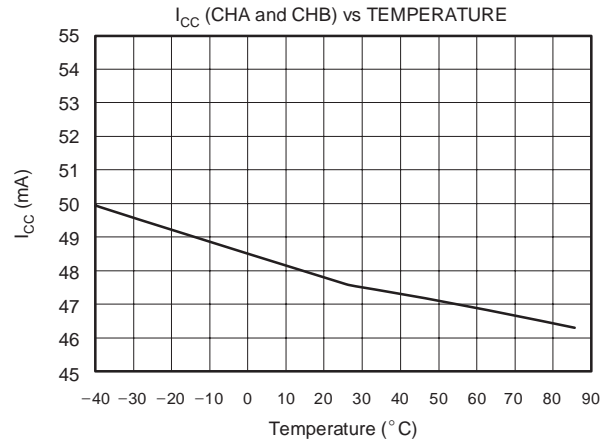
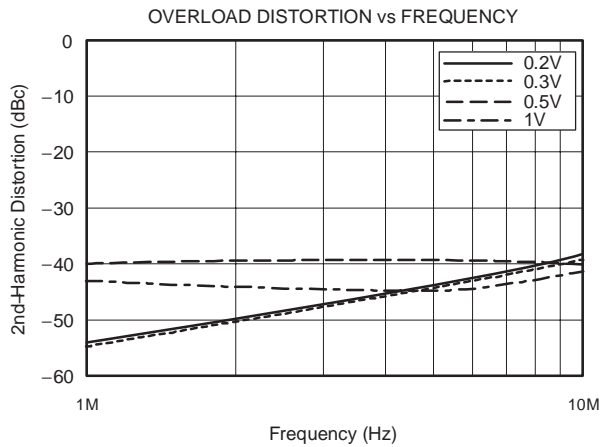

OVERVIEW

The VCA2619 is a dual-channel, VGA consisting of three primary blocks: an Input Buffer, a VCA, and a PGA. All stages are ac coupled, with the coupling into the PGA stage being made variable by placing an external capacitor between the CP1 and CP2 pins. This will be discussed further in the PGA section. By using the internal coupling into the PGA, the result is a high-pass filter characteristic with cutoff at approximately 75kHz. The output PGA naturally rolls off at around 30MHz, making the usable bandwidth of the VCA2619 between 75kHz and 30MHz.

INPUT BUFFER

The input buffer is a unity gain amplifier (gain of +1) with a bandwidth of 100MHz with an input resistance of approximately $600\text{k}\Omega$. The input buffer isolates the circuit driving the VCA2619 inputs from the internal VCA block, which would present a varying impedance to the input circuitry. To allow symmetrical operation of the input buffer, the input to the buffer must be ac coupled through an external capacitor. The recommended value of the capacitor is $0.01\mu\text{F}$. It should be noted that if the capacitor value were increased, the power-on time of the VCA2619 would be increased. If a decrease in the power-on time is needed, the value can be decreased to no less than 100pF .

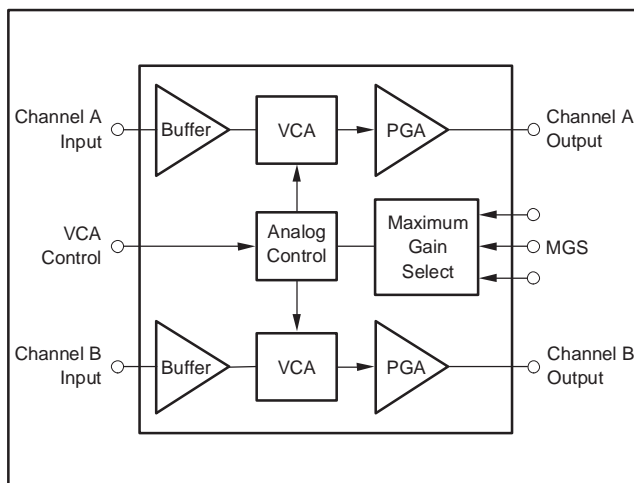

Figure 1. Simplified Block Diagram of the VCA2619.

VOLTAGE-CONTROLLED ATTENUATOR

The magnitude of the VCA input signal from the input buffer is reduced by a programmable attenuation factor, set by the analog VCA Control Voltage ($V_{CA_{CNTL}}$) at pin 24. The maximum attenuation is programmable by using the three MGS bits (pins 21, 22, and 23). Figure 2 illustrates this dual-adjust characteristic.

The MGS bits adjust the overall range of attenuation and maximum gain while the $V_{CA_{CNTL}}$ voltage adjusts the actual attenuation factor. Figure 3 is a simplified version of the voltage control attenuator. Figure 4 illustrates the piecewise approximation to the logarithmic control characteristics. At any given maximum gain setting, the analog variable gain characteristic is linear in dB as a function of the control voltage, and is created as a piecewise approximation of an ideal dB-linear transfer function. The VCA control circuitry is common to both channels of the VCA2619. The range for the $V_{CA_{CNTL}}$ input spans from 0V to 3V. Although overdriving the $V_{CA_{CNTL}}$ input above the recommended 3V maximum will not damage the part, this condition should be avoided.

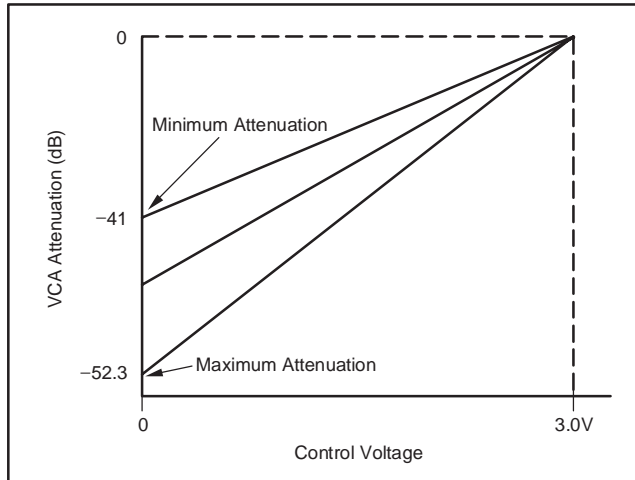

Figure 2. Swept Attenuator Characteristic.

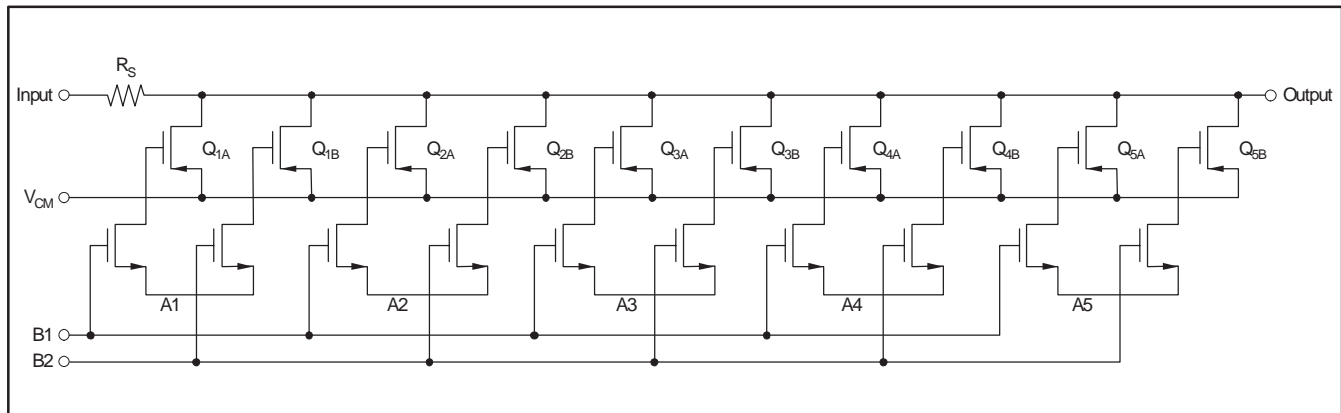

Figure 3. Simplified Attenuator Diagram.

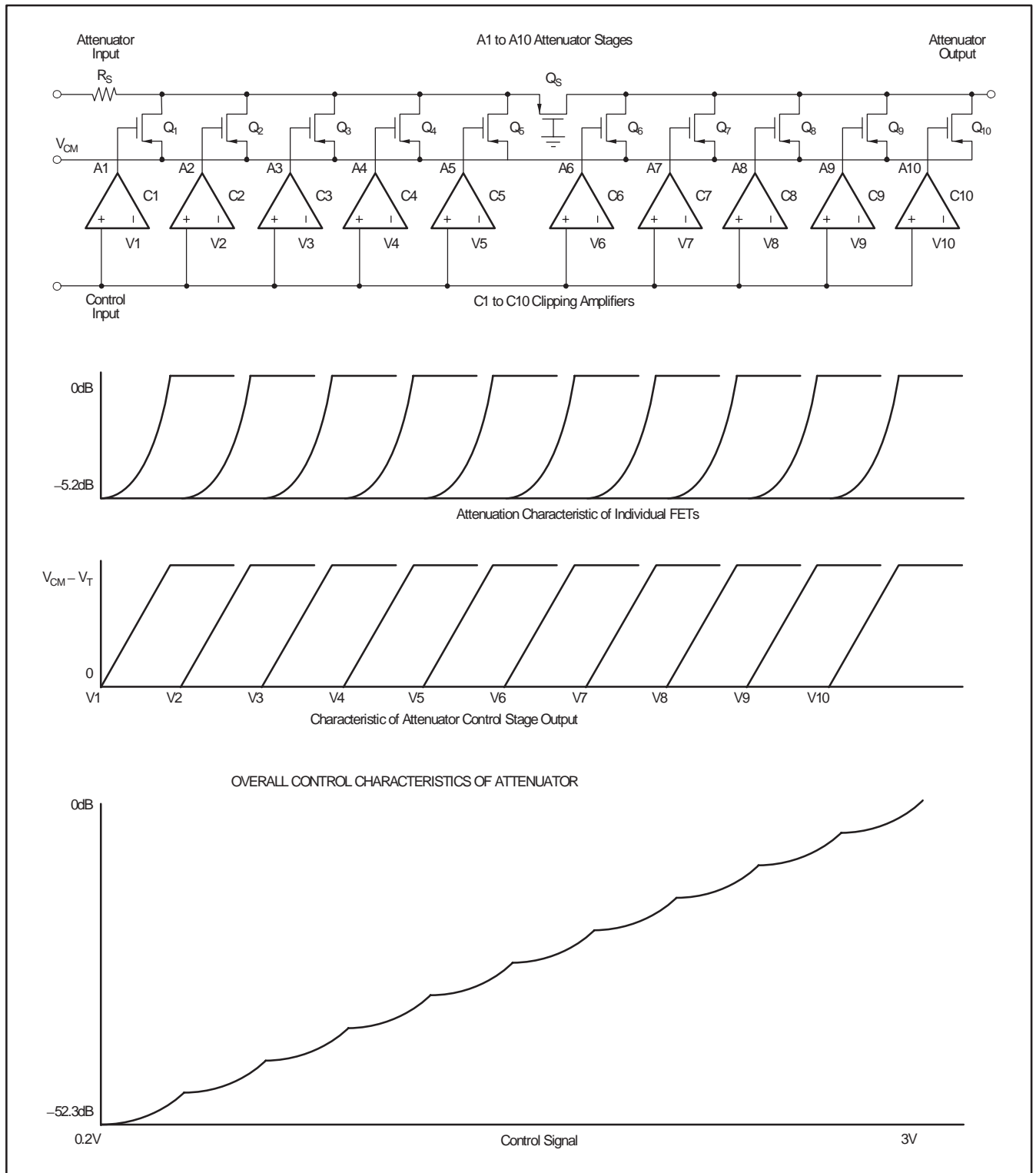

Figure 4. Piecewise Approximation to Logarithmic Control Characteristics.

PGA POST-AMPLIFIER

Figure 5 shows a simplified circuit diagram of the PGA block. As stated before, the input to the PGA is ac coupled with an internal capacitor. Provisions are made so that an external capacitor can be placed in parallel with the internal capacitor, thus lowering the usable low-frequency bandwidth. The low-frequency bandwidth is set by the following equation:

$$\frac{1}{(2 \cdot \pi \cdot 500k\Omega \cdot (220pF + C_{EXTERNAL}))} \quad (1)$$

where $C_{EXTERNAL}$ is the external capacitor value in farads.

Care should be taken to avoid using too large a value of capacitor, as this can increase the power-on delay time.

The PGA gain is programmed with the same MGS bits that control the VCA maximum attenuation factor. For $VCA_{CNTL} = 3V$ (no attenuation), the VCA + PGA gain will be controlled by the programmed PGA gain (29dB to 43dB in approximately 3dB steps). For clarity, the gain and attenuation factors are detailed in Table I.

Table 1. MGS Settings.

MGS SETTING	ATTENUATOR GAIN $VCA_{CNTL} = 0.2V \text{ TO } 3V$	ATTENUATOR + DIFFERENTIAL PGA GAIN
000	Not Valid	Not Valid
001	Not Valid	Not Valid
010	-41.0dB to 0dB	-12dB to 29dB
011	-43.3dB to 0dB	-11.5dB to 31.8dB
100	-46.4dB to 0dB	-11.5dB to 34.9dB
101	-48.2dB to 0dB	-10.6dB to 37.6dB
110	-50.2dB to 0dB	-9.8dB to 40.4dB
111	-52.3dB to 0dB	-9.3dB to 43.3dB

The PGA architecture converts the single-ended signal from the VCA into a differential signal. Low input noise was also a requirement of the PGA design due to the large amount of signal attenuation that can be asserted before the PGA. At minimum VCA attenuation (used for small input signals), the input buffer noise dominates; at maximum VCA attenuation (large input signals), the PGA noise dominates. Note that if the PGA output is single-ended, the apparent gain will be 6dB lower.

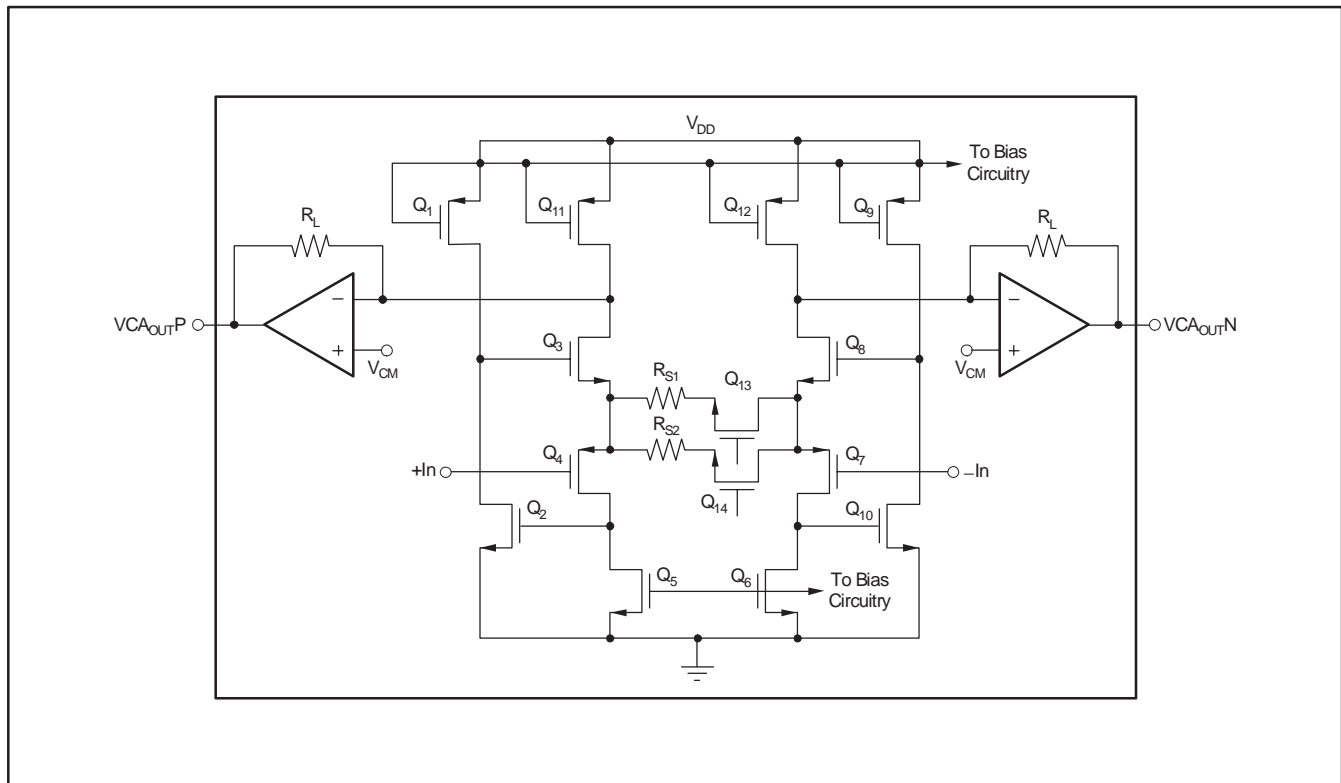

Figure 5. Simplified Block Diagram of PGA.

LAYOUT CONSIDERATIONS

The VCA2619 is an analog amplifier capable of high gain. When working on a PCB layout for the VCA2619, it is recommended to utilize a solid ground plane that is connected to analog ground. This helps to maximize the noise performance of the VCA2619.

Adequate power-supply decoupling must be used in order to achieve the best possible performance. Decoupling capacitors on the VCA_{CNTL} voltage should also be used to help minimize noise. Recommended values can be obtained from the layout diagram of Figure 6.

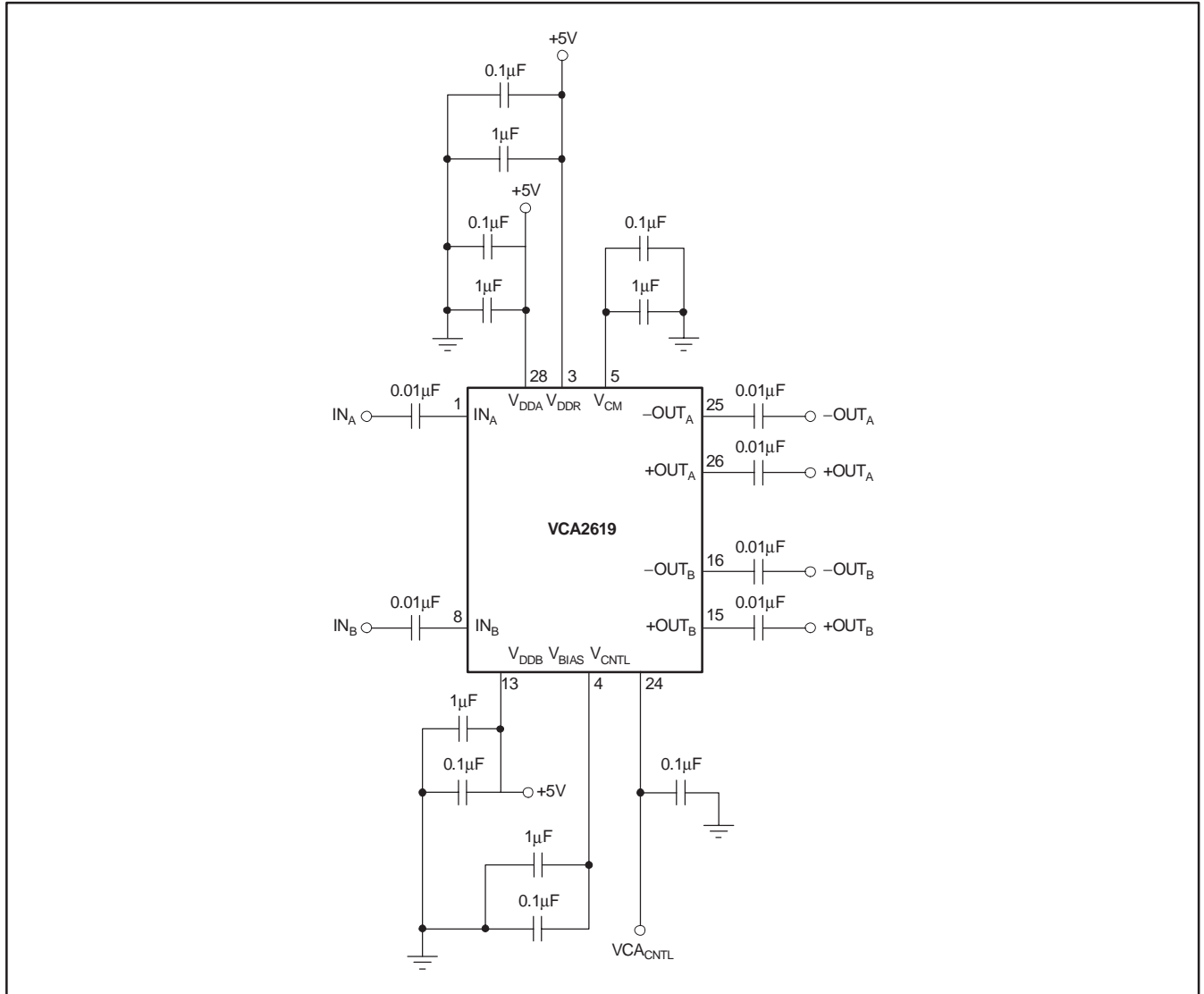

Figure 6. VCA2619 Layout.

PACKAGING INFORMATION

Orderable Device	Status ⁽¹⁾	Package Type	Package Drawing	Pins	Package Qty	Eco Plan ⁽²⁾	Lead/Ball Finish	MSL Peak Temp ⁽³⁾
VCA2619YR	ACTIVE	TQFP	PBS	32	2000	None	Call TI	Call TI
VCA2619YT	ACTIVE	TQFP	PBS	32	250	None	Call TI	Call TI

⁽¹⁾ The marketing status values are defined as follows:

ACTIVE: Product device recommended for new designs.

LIFEBUY: TI has announced that the device will be discontinued, and a lifetime-buy period is in effect.

NRND: Not recommended for new designs. Device is in production to support existing customers, but TI does not recommend using this part in a new design.

PREVIEW: Device has been announced but is not in production. Samples may or may not be available.

OBsolete: TI has discontinued the production of the device.

⁽²⁾ Eco Plan - May not be currently available - please check <http://www.ti.com/productcontent> for the latest availability information and additional product content details.

None: Not yet available Lead (Pb-Free).

Pb-Free (RoHS): TI's terms "Lead-Free" or "Pb-Free" mean semiconductor products that are compatible with the current RoHS requirements for all 6 substances, including the requirement that lead not exceed 0.1% by weight in homogeneous materials. Where designed to be soldered at high temperatures, TI Pb-Free products are suitable for use in specified lead-free processes.

Green (RoHS & no Sb/Br): TI defines "Green" to mean "Pb-Free" and in addition, uses package materials that do not contain halogens, including bromine (Br) or antimony (Sb) above 0.1% of total product weight.

⁽³⁾ MSL, Peak Temp. -- The Moisture Sensitivity Level rating according to the JEDEC industry standard classifications, and peak solder temperature.

Important Information and Disclaimer: The information provided on this page represents TI's knowledge and belief as of the date that it is provided. TI bases its knowledge and belief on information provided by third parties, and makes no representation or warranty as to the accuracy of such information. Efforts are underway to better integrate information from third parties. TI has taken and continues to take reasonable steps to provide representative and accurate information but may not have conducted destructive testing or chemical analysis on incoming materials and chemicals. TI and TI suppliers consider certain information to be proprietary, and thus CAS numbers and other limited information may not be available for release.

In no event shall TI's liability arising out of such information exceed the total purchase price of the TI part(s) at issue in this document sold by TI to Customer on an annual basis.

MECHANICAL DATA

MPQF027 – NOVEMBER 1995

PBS (S-PQFP-G32)

PLASTIC QUAD FLATPACK

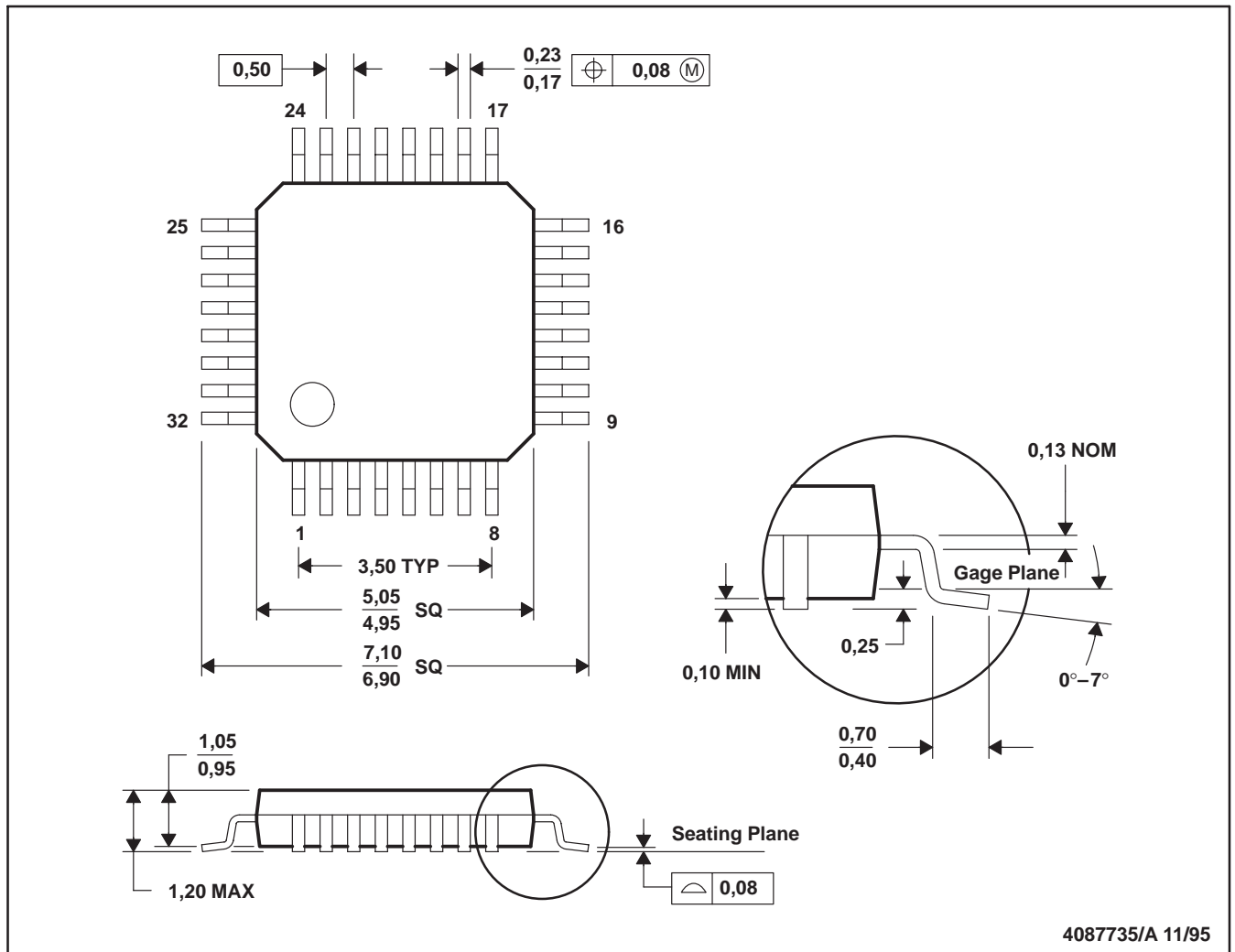

- NOTES: A. All linear dimensions are in millimeters.
 B. This drawing is subject to change without notice.

IMPORTANT NOTICE

Texas Instruments Incorporated and its subsidiaries (TI) reserve the right to make corrections, modifications, enhancements, improvements, and other changes to its products and services at any time and to discontinue any product or service without notice. Customers should obtain the latest relevant information before placing orders and should verify that such information is current and complete. All products are sold subject to TI's terms and conditions of sale supplied at the time of order acknowledgment.

TI warrants performance of its hardware products to the specifications applicable at the time of sale in accordance with TI's standard warranty. Testing and other quality control techniques are used to the extent TI deems necessary to support this warranty. Except where mandated by government requirements, testing of all parameters of each product is not necessarily performed.

TI assumes no liability for applications assistance or customer product design. Customers are responsible for their products and applications using TI components. To minimize the risks associated with customer products and applications, customers should provide adequate design and operating safeguards.

TI does not warrant or represent that any license, either express or implied, is granted under any TI patent right, copyright, mask work right, or other TI intellectual property right relating to any combination, machine, or process in which TI products or services are used. Information published by TI regarding third-party products or services does not constitute a license from TI to use such products or services or a warranty or endorsement thereof. Use of such information may require a license from a third party under the patents or other intellectual property of the third party, or a license from TI under the patents or other intellectual property of TI.

Reproduction of information in TI data books or data sheets is permissible only if reproduction is without alteration and is accompanied by all associated warranties, conditions, limitations, and notices. Reproduction of this information with alteration is an unfair and deceptive business practice. TI is not responsible or liable for such altered documentation.

Resale of TI products or services with statements different from or beyond the parameters stated by TI for that product or service voids all express and any implied warranties for the associated TI product or service and is an unfair and deceptive business practice. TI is not responsible or liable for any such statements.

Following are URLs where you can obtain information on other Texas Instruments products and application solutions:

Products		Applications	
Amplifiers	amplifier.ti.com	Audio	www.ti.com/audio
Data Converters	dataconverter.ti.com	Automotive	www.ti.com/automotive
DSP	dsp.ti.com	Broadband	www.ti.com/broadband
Interface	interface.ti.com	Digital Control	www.ti.com/digitalcontrol
Logic	logic.ti.com	Military	www.ti.com/military
Power Mgmt	power.ti.com	Optical Networking	www.ti.com/opticalnetwork
Microcontrollers	microcontroller.ti.com	Security	www.ti.com/security
		Telephony	www.ti.com/telephony
		Video & Imaging	www.ti.com/video
		Wireless	www.ti.com/wireless

Mailing Address: Texas Instruments
Post Office Box 655303 Dallas, Texas 75265