

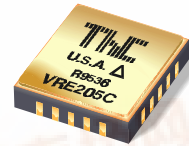

VRE205

Precision Surface Mount Reference Supply



THALER CORPORATION • 2015 N. FORBES BOULEVARD • TUCSON, AZ. 85745 • (520) 882-4000

FEATURES

- PIN AND FUNCTION COMPATIBLE TO REF02
- VERY HIGH ACCURACY: 5.000 V OUTPUT ± 0.4 mV
- EXTREMELY LOW DRIFT: 0.6 ppm/ $^{\circ}$ C -55 $^{\circ}$ C to +125 $^{\circ}$ C
- EXCELLENT STABILITY: 6 ppm/1000 Hrs. Typ.
- EXCELLENT LINE REGULATION: 6 ppm/V Typ.
- WIDE SUPPLY RANGE: +13.5 V to -22.0 V
- HERMETIC 20 TERMINAL CERAMIC LCC
- MILITARY PROCESSING OPTION

APPLICATIONS

- PRECISION A/D and D/A CONVERTERS
- TRANSDUCER EXCITATION
- ACCURATE COMPARATOR THRESHOLD REFERENCE
- HIGH RESOLUTION SERVO SYSTEMS
- DIGITAL VOLTMETERS
- HIGH PRECISION TEST and MEASUREMENT INSTRUMENTS

DESCRIPTION

VRE205 Series Precision Voltage References provides ultrastable +5.000 V outputs with ± 0.4 mV initial accuracy and temperature coefficient as low as 0.6 ppm/ $^{\circ}$ C over the full military temperature range. This improvement in accuracy is made possible by a unique, proprietary multipoint laser compensation technique developed by Thaler Corporation. Significant improvements have been made in other performance parameters as well, including initial accuracy, warm-up drift, line regulation, and long-term stability, making the VRE205 series the most accurate and stable 5V references available.

VRE205 series devices are available in two operating temperature ranges, -25 $^{\circ}$ C to +85 $^{\circ}$ C and -55 $^{\circ}$ C to +125 $^{\circ}$ C, and two performance grades. All devices are packaged in 20 terminal ceramic LCC packages for maximum long-term stability. "M" versions are screened for high reliability and quality.

SELECTION GUIDE

Type	Output	Temperature Operating Range	Max. Volt Deviation
VRE205C	+5V	-25 $^{\circ}$ C to +85 $^{\circ}$ C	0.4mV
VRE205CA	+5V	-25 $^{\circ}$ C to +85 $^{\circ}$ C	0.2mV
VRE205M	+5V	-55 $^{\circ}$ C to +125 $^{\circ}$ C	0.6mV
VRE205MA	+5V	-55 $^{\circ}$ C to +125 $^{\circ}$ C	0.3mV



ELECTRICAL SPECIFICATIONS

VRE205

Vps = ±15V, T = 25°C, RL = 10KΩ unless otherwise noted.

MODEL	C			CA			M			MA			
PARAMETERS	MIN	TYP	MAX	MIN	TYP	MAX	MIN	TYP	MAX	MIN	TYP	MAX	UNITS
ABSOLUTE MAXIMUM RATINGS													
Power Supply	+13.5		+22	*		*	*		*	*		*	V
Operating Temperature	-25		85	*		*	-55		125	-55		125	°C
Storage Temperature	-65		150	*		*	*		*	*		*	°C
Short Circuit Protection	Continuous				*			*			*		
OUTPUT VOLTAGE													
VRE205		+5			*			*			*		V
OUTPUT VOLTAGE ERRORS													
Initial Error			800			400			800			400	μV
Warmup Drift		2			1			2			1		ppm
T _{min} - T _{max} ⁽¹⁾			400			200			600			300	μV
Long-Term Stability		6			*			*			*		ppm/1000hrs
Noise (.1-10Hz)		3			*			*			*		μVpp
OUTPUT CURRENT													
Range	±10			*			*			*			mA
REGULATION													
Line		6	10		*	*		*	*		*	*	ppm/V
Load		3			*			*			*		ppm/mA
OUTPUT ADJUSTMENT													
Range		10			*			*			*		mV
Temperature Coeff.		4			*			*			*		μV/°C/mV
POWER SUPPLY CURRENTS ⁽²⁾													
VRE205 +PS		5	7		*	*		*	*		*	*	mA

NOTES: *Same as C Models.

1. Using the box method, the specified value is the maximum deviation from the output voltage at 25°C over the specified operating temperature range.

2. The specified values are unloaded.

TYPICAL PERFORMANCE CURVES

V_{OUT} vs. TEMPERATURE

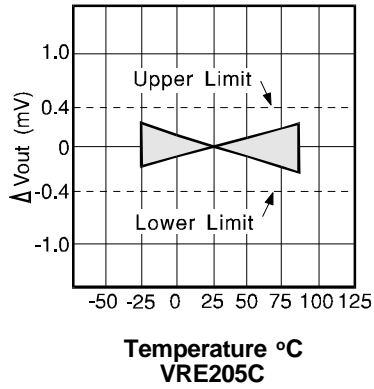

V_{OUT} vs. TEMPERATURE

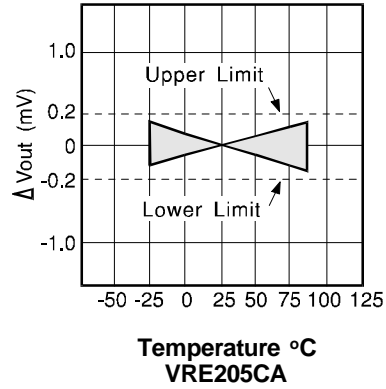

V_{OUT} vs. TEMPERATURE

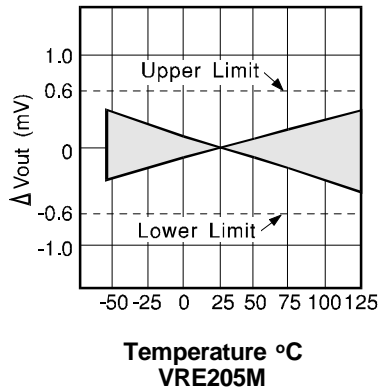

V_{OUT} vs. TEMPERATURE

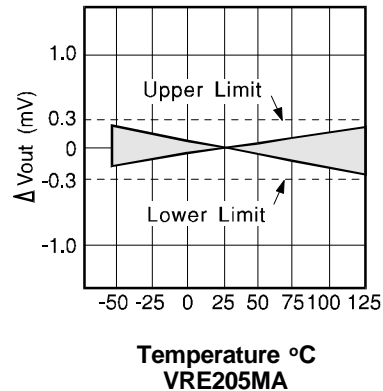

QUIESCENT CURRENT vs. TEMP

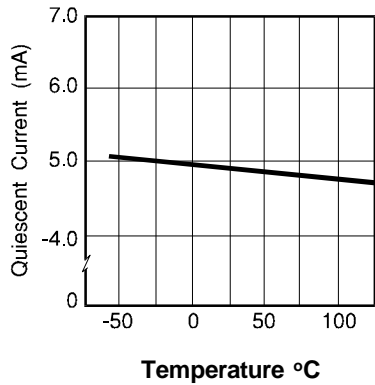

JUNCTION TEMP. RISE vs. OUTPUT CURRENT

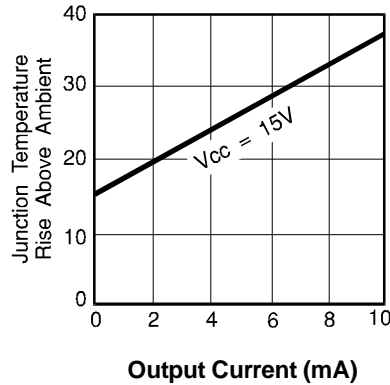

PSRR vs. FREQUENCY

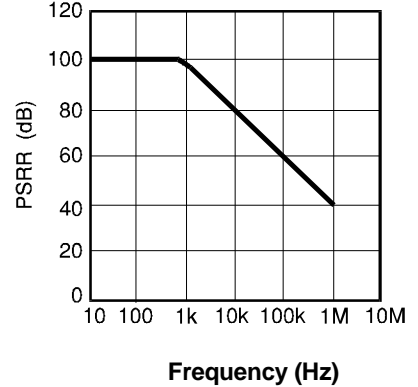

EXTERNAL CONNECTIONS

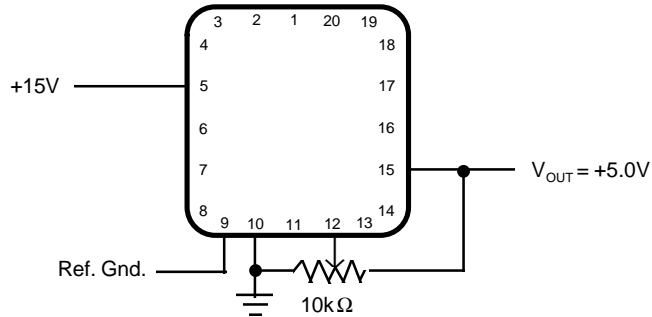
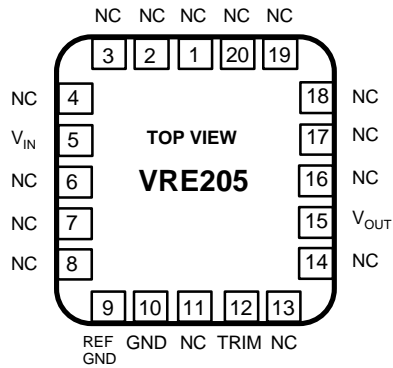
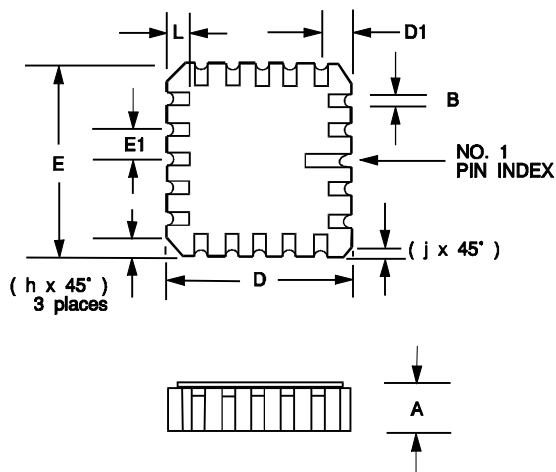

FIGURE 2

PIN CONFIGURATION



MECHANICAL



DIM	INCHES		MILLIMETER	
	MIN	MAX	MIN	MAX
A	0.090	0.110	2.29	2.79
B	0.022	0.028	0.56	0.71
D	0.342	0.358	8.68	9.09
D1	0.048	0.052	1.22	1.32
E	0.342	0.358	8.68	9.09
E1	0.045	0.055	1.114	1.40
j	0.010 REF		.254 REF	
h	0.040 REF		1.02 REF	
L	0.045	0.055	1.14	1.40