

## Features

- Serial Peripheral Interface (SPI) Compatible
- Supports SPI Modes 0 (0,0) and 3 (1,1)
- 10 MHz Clock Rate
- 128-Byte Page Mode Only for Write Operations
- Low-Voltage and Standard-Voltage Operation
  - 5.0 ( $V_{CC} = 4.5V$  to  $5.5V$ )
  - 2.7 ( $V_{CC} = 2.7V$  to  $5.5V$ )
  - 1.8 ( $V_{CC} = 1.8V$  to  $3.6V$ )
- Block Write Protection
  - Protect 1/4, 1/2, or Entire Array
- Write Protect ( $\overline{WP}$ ) Pin and Write Disable Instructions for Both Hardware and Software Data Protection
- High Reliability
  - Endurance: 100K Write Cycles
  - Data Retention: > 40 Years
  - ESD Protection: > 3000V
- 8-Pin PDIP, 8-Pin EIAJ SOIC, and 8-Pin Leadless Array Package

## Description

The AT25HP256/512 provides 262,144/524,288 bits of serial electrically erasable programmable read only memory (EEPROM) organized as 32,768/65,536 words of 8-bits each. The device is optimized for use in many industrial and commercial applications where high-speed, low-power, and low-voltage operation are essential. The AT25HP256/512 is available in a space saving 8-pin PDIP (AT25HP256/512), 8-pin EIAJ SOIC (AT25HP256), and 8-pin Leadless Array (AT25HP256/512) packages. In

(continued)

## Pin Configurations

Pin Name	Function
$\overline{CS}$	Chip Select
SCK	Serial Data Clock
SI	Serial Data Input
SO	Serial Data Output
GND	Ground
VCC	Power Supply
$\overline{WP}$	Write Protect
$\overline{HOLD}$	Suspends Serial Input

8-Pin PDIP

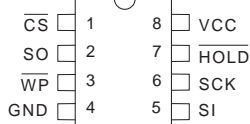

8-Pin SOIC

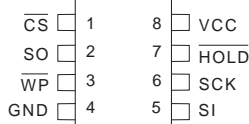

8-Pin Leadless Array

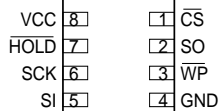

Bottom View



## SPI Serial EEPROMs

256K (32,768 x 8)

512K (65,536 x 8)

## AT25HP256 AT25HP512 Preliminary



In addition, the entire family is available in 5.0V (4.5V to 5.5V), 2.7V (2.7V to 5.5V), and 1.8V (1.8V to 3.6V) versions.

The AT25HP256/512 is enabled through the Chip Select pin ( $\overline{CS}$ ) and accessed via a 3-wire interface consisting of Serial Data Input (SI), Serial Data Output (SO), and Serial Clock (SCK). All programming cycles are completely self-timed, and no separate ERASE cycle is required before WRITE.

BLOCK WRITE protection is enabled by programming the status register with top 1/4, top 1/2 or entire array of write protection. Separate program enable and program disable instructions are provided for additional data protection. Hardware data protection is provided via the  $\overline{WP}$  pin to protect against inadvertent write attempts to the status register. The  $\overline{HOLD}$  pin may be used to suspend any serial communication without resetting the serial sequence.

### Absolute Maximum Ratings\*

Operating Temperature .....	-55°C to +125°C
Storage Temperature .....	-65°C to +150°C
Voltage on Any Pin with Respect to Ground .....	-1.0V to +7.0V
Maximum Operating Voltage .....	6.25V
DC Output Current .....	5.0 mA

\*NOTICE: Stresses beyond those listed under "Absolute Maximum Ratings" may cause permanent damage to the device. This is a stress rating only and functional operation of the device at these or any other conditions beyond those indicated in the operational sections of this specification is not implied. Exposure to absolute maximum rating conditions for extended periods may affect device reliability.

### Block Diagram

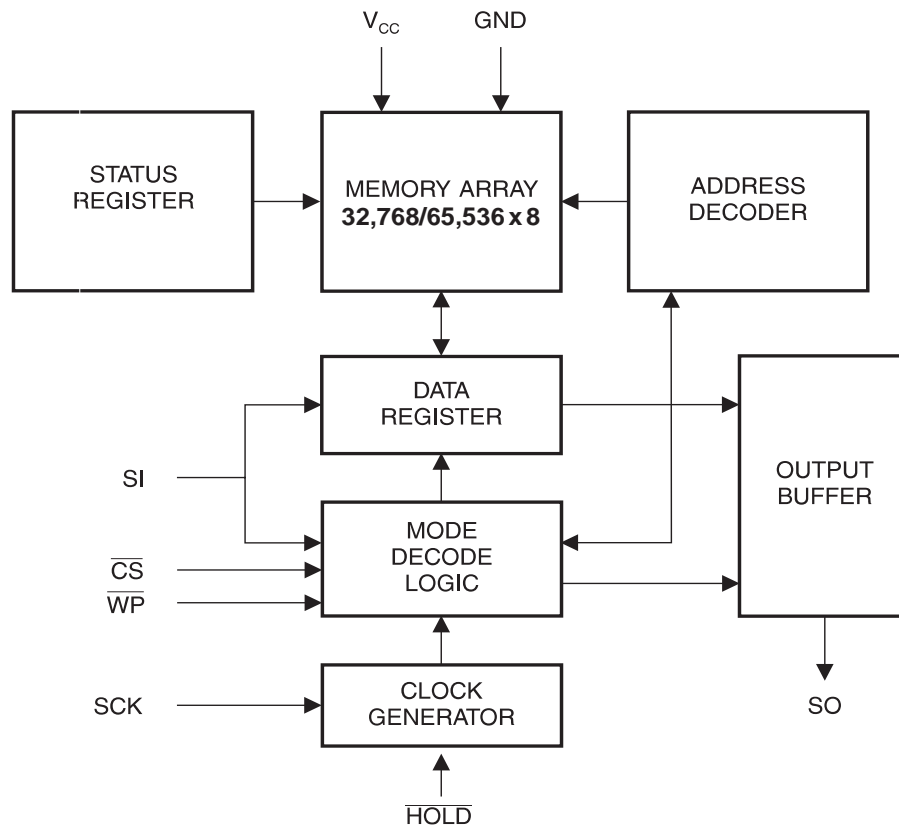

## Pin Capacitance<sup>(1)</sup>

Applicable over recommended operating range from  $T_A = 25^\circ\text{C}$ ,  $f = 1.0\text{ MHz}$ ,  $V_{CC} = +5.0\text{V}$  (unless otherwise noted).

	Test Conditions	Max	Units	Conditions
$C_{OUT}$	Output Capacitance (SO)	8	pF	$V_{OUT} = 0\text{V}$
$C_{IN}$	Input Capacitance ( $\overline{CS}$ , SCK, SI, $\overline{WP}$ , HOLD)	6	pF	$V_{IN} = 0\text{V}$

Note: 1. This parameter is characterized and is not 100% tested.

## DC Characteristics

Applicable over recommended operating range from:  $T_{AI} = -40^\circ\text{C}$  to  $+85^\circ\text{C}$ ,  $V_{CC} = +1.8\text{V}$  to  $+5.5\text{V}$ ,  $T_{AC} = 0^\circ\text{C}$  to  $+70^\circ\text{C}$ ,  $V_{CC} = +1.8\text{V}$  to  $+5.5\text{V}$  (unless otherwise noted).

Symbol	Parameter	Test Condition	Min	Typ	Max	Units
$V_{CC1}$	Supply Voltage		1.8		3.6	V
$V_{CC2}$	Supply Voltage		2.7		5.5	V
$V_{CC3}$	Supply Voltage		4.5		5.5	V
$I_{CC1}$	Supply Current	$V_{CC} = 5.0\text{V}$ at 5 MHz, SO = Open Read		6.0	10.0	mA
$I_{CC2}$	Supply Current	$V_{CC} = 5.0\text{V}$ at 5 MHz, SO = Open Write		4.0	7.0	mA
$I_{SB1}$	Standby Current	$V_{CC} = 1.8\text{V}$ , $\overline{CS} = V_{CC}$		0.1	2.0	$\mu\text{A}$
$I_{SB2}$	Standby Current	$V_{CC} = 2.7\text{V}$ , $\overline{CS} = V_{CC}$		0.2	2.0	$\mu\text{A}$
$I_{SB3}$	Standby Current	$V_{CC} = 5.0\text{V}$ , $\overline{CS} = V_{CC}$		2.0	5.0	$\mu\text{A}$
$I_{IL}$	Input Leakage	$V_{IN} = 0\text{V}$ to $V_{CC}$	-3.0		3.0	$\mu\text{A}$
$I_{OL}$	Output Leakage	$V_{IN} = 0\text{V}$ to $V_{CC}$ , $T_{AC} = 0^\circ\text{C}$ to $70^\circ\text{C}$	-3.0		3.0	$\mu\text{A}$
$V_{IL}^{(1)}$	Input Low Voltage		-0.6		$V_{CC} \times 0.3$	V
$V_{IH}^{(1)}$	Input High Voltage		$V_{CC} \times 0.7$		$V_{CC} + 0.5$	V
$V_{OL1}$	Output Low Voltage	$4.5\text{V} \leq V_{CC} \leq 5.5\text{V}$			0.4	V
$V_{OH1}$	Output High Voltage			$I_{OL} = 3.0\text{ mA}$		V
$V_{OL2}$	Output Low Voltage	$1.8\text{V} \leq V_{CC} \leq 3.6\text{V}$		$V_{CC} - 0.8$		V
$V_{OH2}$	Output High Voltage			$I_{OH} = -1.6\text{ mA}$		V
					0.2	V
			$V_{CC} - 0.2$			V

Note: 1.  $V_{IL}$  and  $V_{IH}$  max are reference only and are not tested.

## AC Characteristics

Applicable over recommended operating range from  $T_A = -40^\circ\text{C}$  to  $+85^\circ\text{C}$ ,  $V_{CC} = \text{As Specified}$ ,  
 $C_L = 1$  TTL Gate and 30 pF (unless otherwise noted).

Symbol	Parameter	Voltage	Min	Max	Units
$f_{\text{SCK}}$	SCK Clock Frequency	4.5 - 5.5 2.7 - 5.5 1.8 - 3.6	0 0 0	10 5 TBD	MHz
$t_{\text{RI}}$	Input Rise Time	4.5 - 5.5 2.7 - 5.5 1.8 - 3.6		2 2 TBD	$\mu\text{s}$
$t_{\text{FI}}$	Input Fall Time	4.5 - 5.5 2.7 - 5.5 1.8 - 3.6		2 2 TBD	$\mu\text{s}$
$t_{\text{WH}}$	SCK High Time	4.5 - 5.5 2.7 - 5.5 1.8 - 3.6	40 80 TBD		ns
$t_{\text{WL}}$	SCK Low Time	4.5 - 5.5 2.7 - 5.5 1.8 - 3.6	40 80 TBD		ns
$t_{\text{CS}}$	$\overline{\text{CS}}$ High Time	4.5 - 5.5 2.7 - 5.5 1.8 - 3.6	50 100 TBD		ns
$t_{\text{CSS}}$	$\overline{\text{CS}}$ Setup Time	4.5 - 5.5 2.7 - 5.5 1.8 - 3.6	50 100 TBD		ns
$t_{\text{CSH}}$	$\overline{\text{CS}}$ Hold Time	4.5 - 5.5 2.7 - 5.5 1.8 - 3.6	50 100 TBD		ns
$t_{\text{SU}}$	Data In Setup Time	4.5 - 5.5 2.7 - 5.5 1.8 - 3.6	12 20 TBD		ns
$t_{\text{H}}$	Data In Hold Time	4.5 - 5.5 2.7 - 5.5 1.8 - 3.6	10 20 TBD		ns
$t_{\text{HD}}$	$\overline{\text{Hold}}$ Setup Time	4.5 - 5.5 2.7 - 5.5 1.8 - 3.6	25 50 TBD		ns
$t_{\text{CD}}$	$\overline{\text{Hold}}$ Hold Time	4.5 - 5.5 2.7 - 5.5 1.8 - 3.6	25 50 TBD		ns
$t_{\text{V}}$	Output Valid	4.5 - 5.5 2.7 - 5.5 1.8 - 3.6	0 0 0	40 80 TBD	ns
$t_{\text{HO}}$	Output Hold Time	4.5 - 5.5 2.7 - 5.5 1.8 - 3.6	0 0 0		ns

### AC Characteristics (Continued)

Applicable over recommended operating range from  $T_A = -40^{\circ}\text{C}$  to  $+85^{\circ}\text{C}$ ,  $V_{CC} = \text{As Specified}$ ,  $C_L = 1$  TTL Gate and 30 pF (unless otherwise noted).

Symbol	Parameter	Voltage	Min	Max	Units
$t_{LZ}$	$\overline{\text{Hold}}$ to Output Low Z	4.5 - 5.5	0	100	ns
		2.7 - 5.5	0	200	
		1.8 - 3.6	0	TBD	
$t_{HZ}$	$\overline{\text{Hold}}$ to Output High Z	4.5 - 5.5		100	ns
		2.7 - 5.5		200	
		1.8 - 3.6		TBD	
$t_{DIS}$	Output Disable Time	4.5 - 5.5		100	ns
		2.7 - 5.5		100	
		1.8 - 3.6		TBD	
$t_{WC}$	Write Cycle Time	4.5 - 5.5		5	ms
		2.7 - 5.5		10	
		1.8 - 3.6		TBD	
Endurance <sup>(1)</sup>	5.0V, 25°C, Page Mode	4.5 - 5.5 2.7 - 5.5 1.8 - 3.6	100K		Write Cycles

Note: 1. This parameter is characterized and is not 100% tested.

## Serial Interface Description

**MASTER:** The device that generates the serial clock.

**SLAVE:** Because the Serial Clock pin (SCK) is always an input, the AT25HP256/512 always operates as a slave.

**TRANSMITTER/RECEIVER:** The AT25HP256/512 has separate pins designated for data transmission (SO) and reception (SI).

**MSB:** The Most Significant Bit (MSB) is the first bit transmitted and received.

**SERIAL OP-CODE:** After the device is selected with  $\overline{CS}$  going low, the first byte will be received. This byte contains the op-code that defines the operations to be performed.

**INVALID OP-CODE:** If an invalid op-code is received, no data will be shifted into the AT25HP256/512, and the serial output pin (SO) will remain in a high impedance state until the falling edge of  $\overline{CS}$  is detected again. This will reinitialize the serial communication.

**CHIP SELECT:** The AT25HP256/512 is selected when the  $\overline{CS}$  pin is low. When the device is not selected, data will not be accepted via the SI pin, and the serial output pin (SO) will remain in a high impedance state.

**HOLD:** The  $\overline{HOLD}$  pin is used in conjunction with the  $\overline{CS}$  pin to select the AT25HP256/512. When the device is selected and a serial sequence is underway,  $\overline{HOLD}$  can be used to pause the serial communication with the master device without resetting the serial sequence. To pause, the  $\overline{HOLD}$  pin must be brought low while the SCK pin is low. To resume serial communication, the  $\overline{HOLD}$  pin is brought high while the SCK pin is low (SCK may still toggle during  $\overline{HOLD}$ ). Inputs to the SI pin will be ignored while the SO pin is in the high impedance state.

**WRITE PROTECT:** The write protect pin ( $\overline{WP}$ ) will allow normal read/write operations when held high. When the  $\overline{WP}$  pin is brought low and WPEN bit is "1", all write operations to the status register are inhibited.  $\overline{WP}$  going low while  $\overline{CS}$  is still low will interrupt a write to the status register. If the internal write cycle has already been initiated,  $\overline{WP}$  going low will have no effect on any write operation to the

status register. The  $\overline{WP}$  pin function is blocked when the WPEN bit in the status register is "0". This will allow the user to install the AT25HP256/512 in a system with the  $\overline{WP}$  pin tied to ground and still be able to write to the status register. All  $\overline{WP}$  pin functions are enabled when the WPEN bit is set to "1".

## SPI Serial Interface

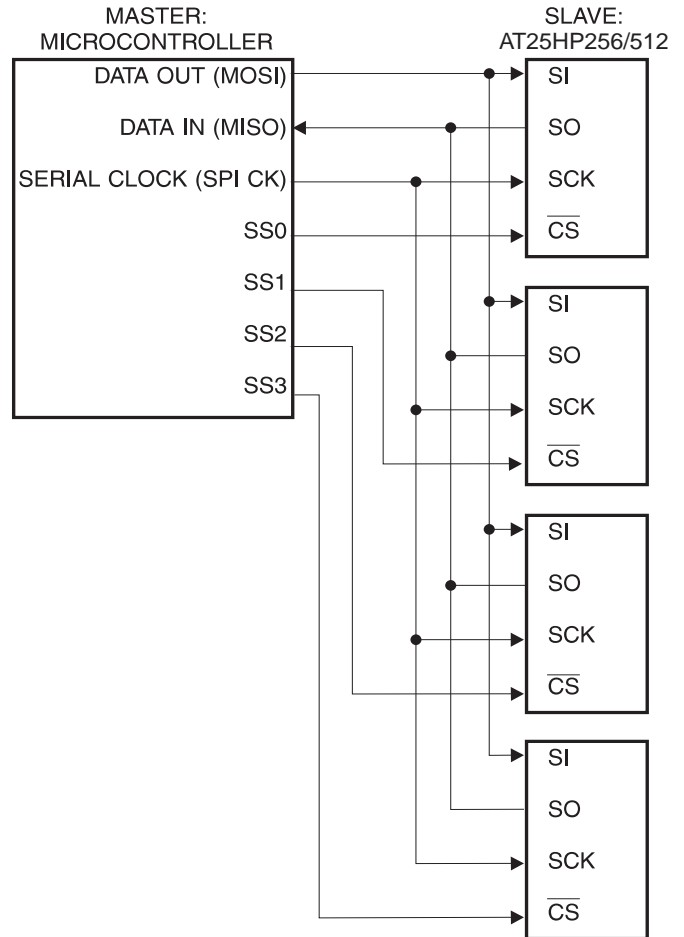

## Functional Description

The AT25HP256/512 is designed to interface directly with the synchronous serial peripheral interface (SPI) of the 6800 type series of microcontrollers.

The AT25HP256/512 utilizes an 8-bit instruction register. The list of instructions and their operation codes are contained in Table 1. All instructions, addresses, and data are transferred with the MSB first and start with a high-to-low CS transition.

**Table 1.** Instruction Set for the AT25HP256/512

Instruction Name	Instruction Format	Operation
WREN	0000 X110	Set Write Enable Latch
WRDI	0000 X100	Reset Write Enable Latch
RDSR	0000 X101	Read Status Register
WRSR	0000 X001	Write Status Register
READ	0000 X011	Read Data from Memory Array
WRITE	0000 X010	Write Data to Memory Array

**WRITE ENABLE (WREN):** The device will power up in the write disable state when  $V_{CC}$  is applied. All programming instructions must therefore be preceded by a Write Enable instruction.

**WRITE DISABLE (WRDI):** To protect the device against inadvertent writes, the Write Disable instruction disables all programming modes. The WRDI instruction is independent of the status of the  $\overline{WP}$  pin.

**READ STATUS REGISTER (RDSR):** The Read Status Register instruction provides access to the status register. The READY/BUSY and Write Enable status of the device can be determined by the RDSR instruction. Similarly, the Block Write Protection bits indicate the extent of protection employed. These bits are set by using the WRSR instruction.

**Table 2.** Status Register Format

Bit 7	Bit 6	Bit 5	Bit 4	Bit 3	Bit 2	Bit 1	Bit 0
WPEN	X	X	X	BP1	BP0	WEN	$\overline{RDY}$

**Table 3.** Read Status Register Bit Definition

Bit	Definition
Bit 0 ( $\overline{RDY}$ )	Bit 0 = 0 ( $\overline{RDY}$ ) indicates the device is READY. Bit 0 = 1 indicates the write cycle is in progress.
Bit 1 (WEN)	Bit 1 = 0 indicates the device is <i>not</i> WRITE ENABLED. Bit 1 = 1 indicates the device is WRITE ENABLED.
Bit 2 (BP0)	See Table 4.
Bit 3 (BP1)	See Table 4.
Bits 4-6 are 0s when device is not in an internal write cycle.	
Bit 7 (WPEN)	See Table 5.
Bits 0-7 are 1s during an internal write cycle.	

**WRITE STATUS REGISTER (WRSR):** The WRSR instruction allows the user to select one of four levels of protection. The AT25HP256/512 is divided into four array segments. Top quarter (1/4), top half (1/2), or all of the memory segments can be protected. Any of the data within any selected segment will therefore be READ only. The block write protection levels and corresponding status register control bits are shown in Table 4.

The three bits, BP0, BP1, and WPEN are nonvolatile cells that have the same properties and functions as the regular memory cells (e.g. WREN,  $t_{WC}$ , RDSR).

**Table 4.** Block Write Protect Bits

Level	Status Register Bits		Array Addresses Protected
	BP1	BP0	AT25HP256/512
0	0	0	None
1(1/4)	0	1	6000 - 7FFF/C000 - FFFF
2(1/2)	1	0	4000 - 7FFF/8000 - FFFF
3(All)	1	1	0000 - 7FFF/0000 - FFFF

The WRSR instruction also allows the user to enable or disable the write protect ( $\overline{WP}$ ) pin through the use of the Write Protect Enable (WPEN) bit. Hardware write protection is enabled when the  $\overline{WP}$  pin is low and the WPEN bit is "1". Hardware write protection is disabled when *either* the  $\overline{WP}$  pin is high or the WPEN bit is "0." When the device is hardware write protected, writes to the Status Register, including the Block Protect bits and the WPEN bit, and the block-protected sections in the memory array are disabled.

Writes are only allowed to sections of the memory which are not block-protected.

**NOTE:** When the WPEN bit is hardware write protected, it cannot be changed back to “0”, as long as the  $\overline{WP}$  pin is held low.

**Table 5.** WPEN Operation

WPEN	WP	WEN	Protected Blocks	Unprotected Blocks	Status Register
0	X	0	Protected	Protected	Protected
0	X	1	Protected	Writable	Writable
1	Low	0	Protected	Protected	Protected
1	Low	1	Protected	Writable	Protected
X	High	0	Protected	Protected	Protected
X	High	1	Protected	Writable	Writable

**READ SEQUENCE (READ):** Reading the AT25HP256/512 via the SO (Serial Output) pin requires the following sequence. After the  $\overline{CS}$  line is pulled low to select a device, the READ op-code is transmitted via the SI line followed by the byte address to be read (Refer to Table 6). Upon completion, any data on the SI line will be ignored. The data (D7-D0) at the specified address is then shifted out onto the SO line. If only one byte is to be read, the  $\overline{CS}$  line should be driven high after the data comes out. The READ sequence can be continued since the byte address is automatically incremented and data will continue to be shifted out. When the highest address is reached, the address counter will roll over to the lowest address allowing the entire memory to be read in one continuous READ cycle.

**WRITE SEQUENCE (WRITE):** In order to program the AT25HP256/512, two separate instructions must be executed. First, the device **must be write enabled** via the Write Enable (WREN) Instruction. Then a Write (WRITE) Instruction may be executed. Also, the address of the memory location(s) to be programmed must be outside the protected address field location selected by the Block Write

Protection Level. During an internal write cycle, all commands will be ignored except the RDSR instruction.

A Write Instruction requires the following sequence. After the  $\overline{CS}$  line is pulled low to select the device, the WRITE op-code is transmitted via the SI line followed by the byte address and the data (D7-D0) to be programmed (Refer to Table 6). Programming will start after the  $\overline{CS}$  pin is brought high. (The LOW to High transition of the  $\overline{CS}$  pin must occur during the SCK low time immediately after clocking in the D0 (LSB) data bit.

The READY/BUSY status of the device can be determined by initiating a READ STATUS REGISTER (RDSR) Instruction. If Bit 0 = 1, the WRITE cycle is still in progress. If Bit 0 = 0, the WRITE cycle has ended. Only the READ STATUS REGISTER instruction is enabled during the WRITE programming cycle.

The AT25HP256/512 is capable of a 128-byte PAGE WRITE operation. After each byte of data is received, the seven low order address bits are internally incremented by one; the high order bits of the address will remain constant. If more than 128-bytes of data are transmitted, the address counter will roll over and the previously written data will be overwritten. The AT25HP256/512 is automatically returned to the write disable state at the completion of a WRITE cycle.

**NOTE:** If the device is not Write enabled (WREN), the device will ignore the Write instruction and will return to the standby state, when  $\overline{CS}$  is brought high. A new CS falling edge is required to re-initiate the serial communication.

**Table 6.** Address Key

Address	AT25HP256/512
$A_N$	$A_{14} - A_0 / A_{15} - A_0$
Don't Care Bits	$A_{15} / \text{none}$

**NOTE:** 128-byte PAGE WRITE operation only. Content of the page in the array will not be guaranteed if less than 128 bytes of data is received (byte write is not supported).

### Timing Diagrams (for SPI Mode 0 (0, 0))

#### Synchronous Data Timing

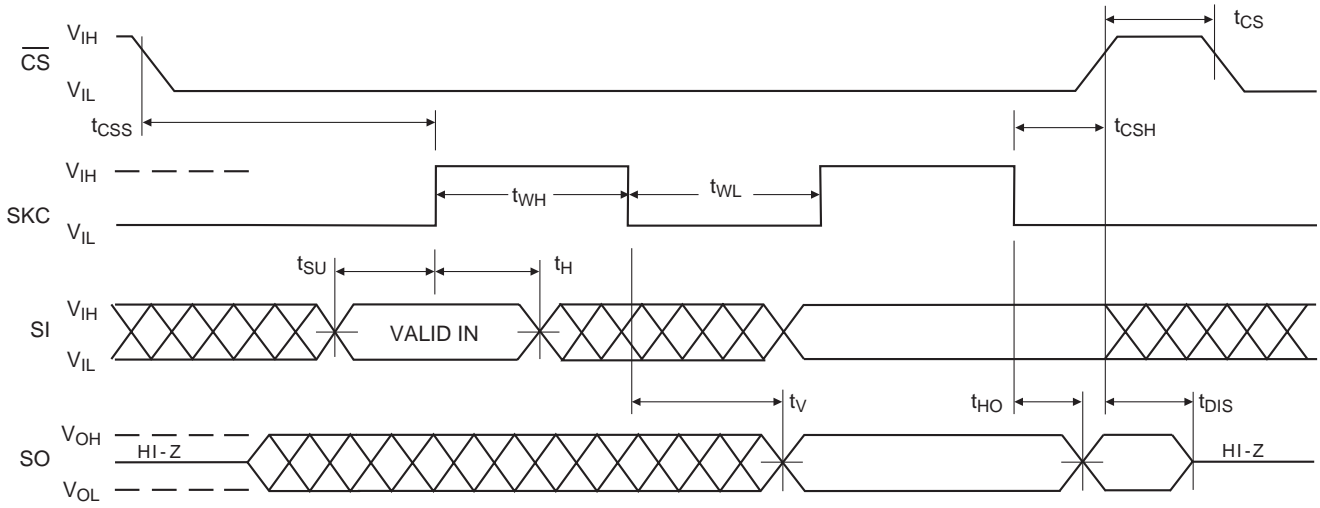

#### WREN Timing

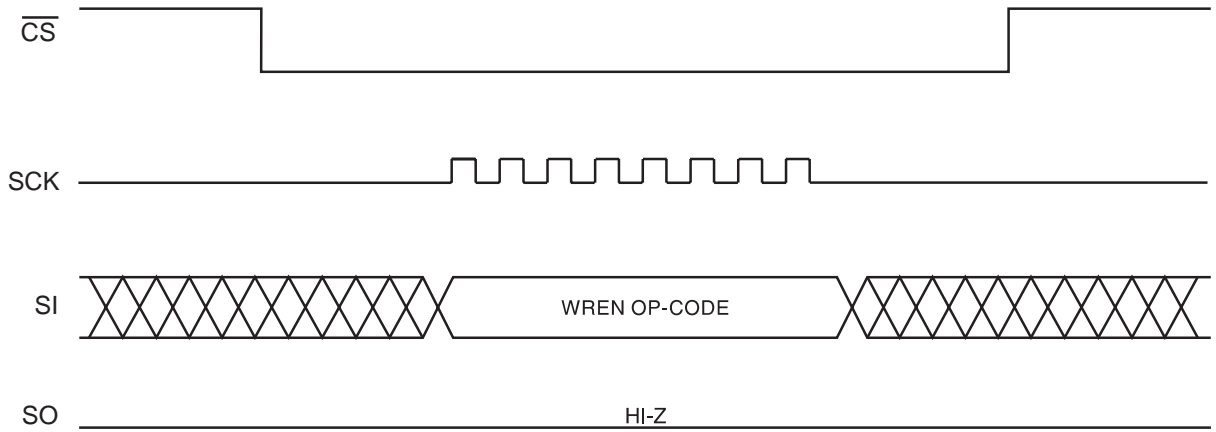

#### WRDI Timing

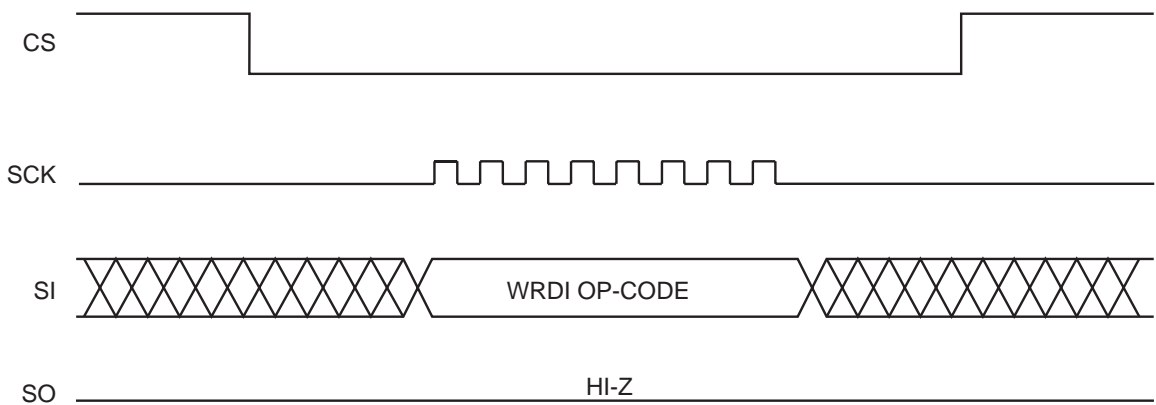

### RDSR Timing

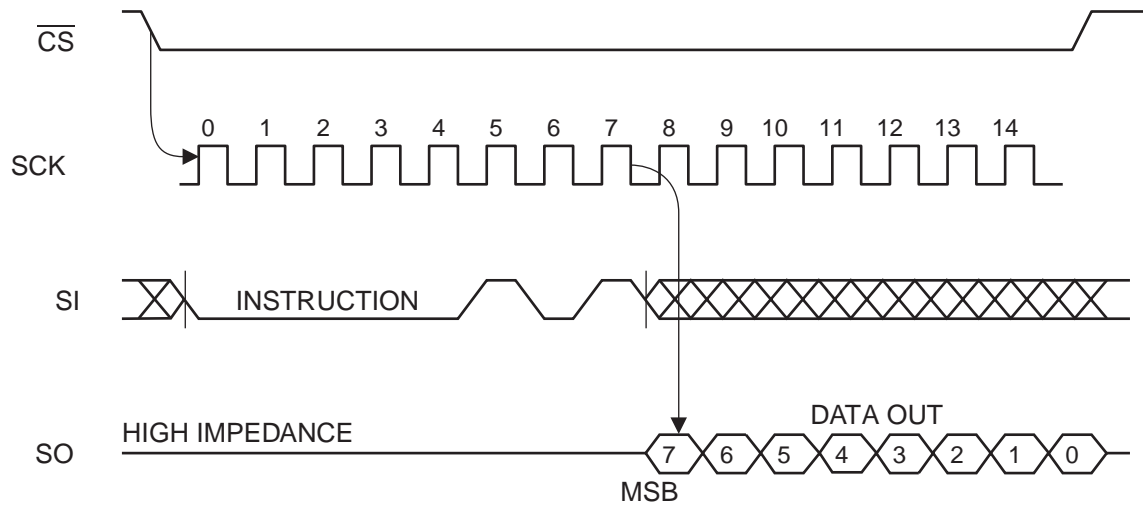

### WRSR Timing

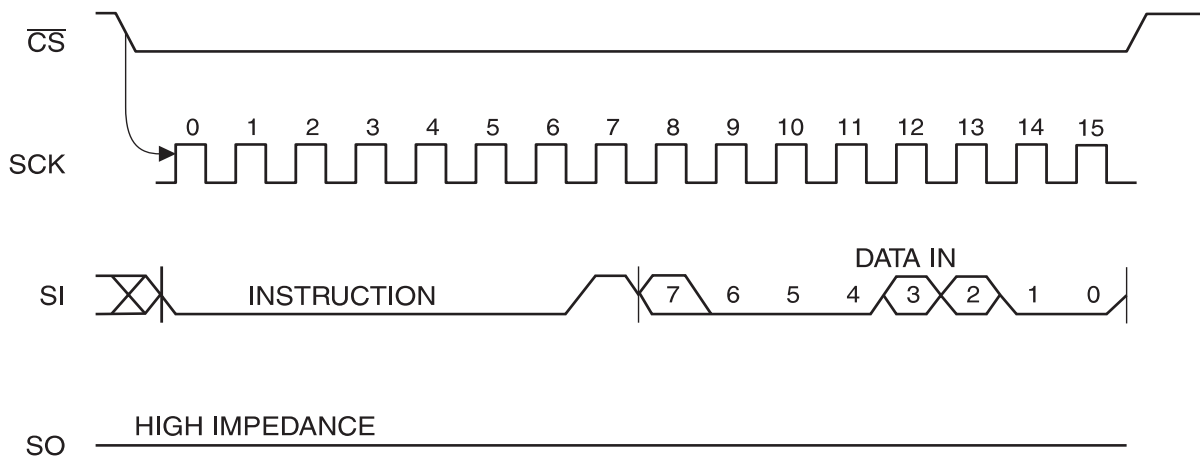

### READ Timing

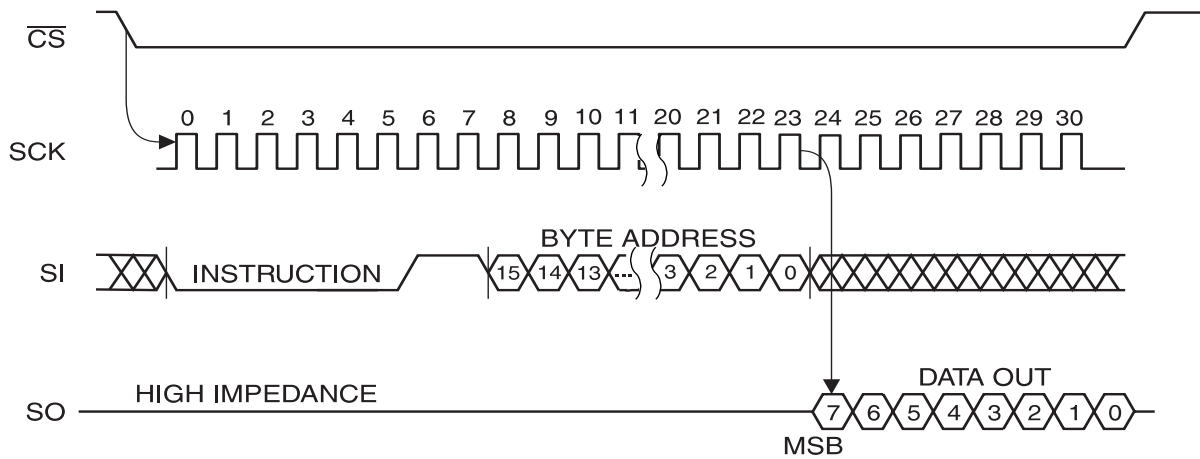

WRITE Timing (AT25HP256)

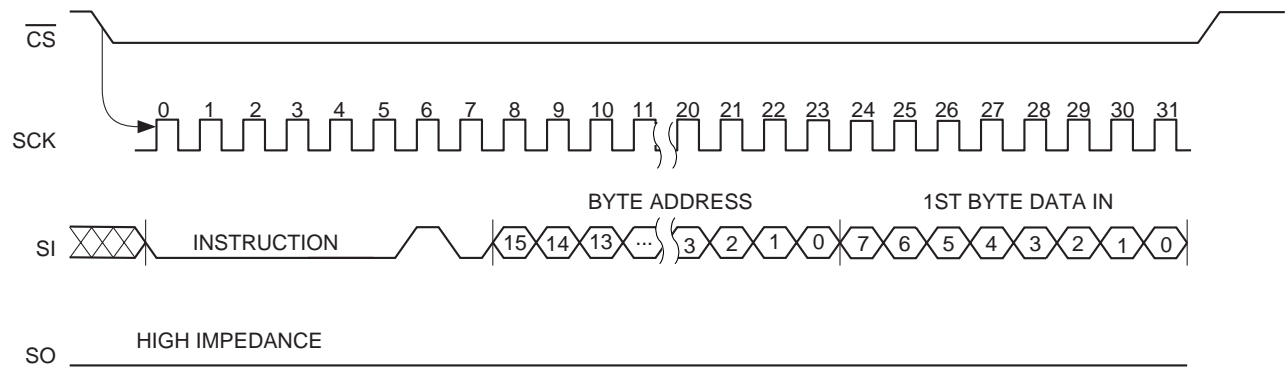

### PAGE WRITE Timing (AT25HP512)

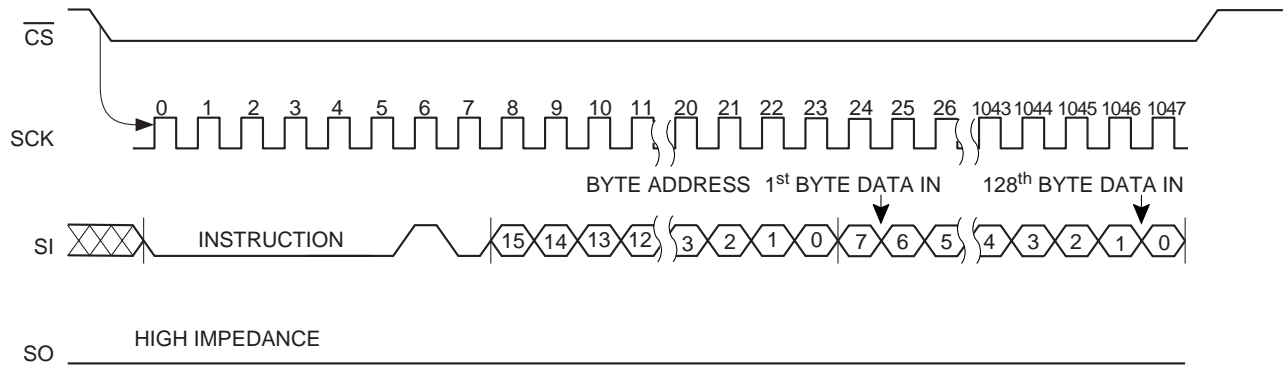

### HOLD Timing

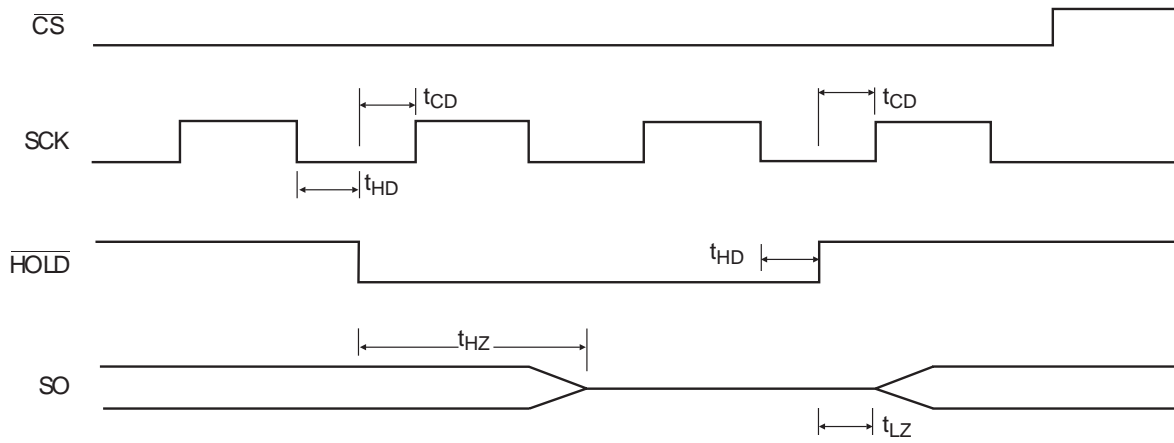

## AT25HP256 Ordering Information

$t_{WC}$ (max) (ms)	$I_{CC}$ (max) ( $\mu A$ )	$I_{SB}$ (max) ( $\mu A$ )	$f_{MAX}$ (kHz)	Ordering Code	Package	Operation Range
5	8000	7.0	10000	AT25HP256-10CC AT25HP256C1-10CC AT25HP256-10PC AT25HP256W-10SC	8C 8C1 8P3 8S2	Commercial (0°C to 70°C)
	8000	7.0	10000	AT25HP256-10CI AT25HP256C1-10CI AT25HP256-10PI AT25HP256W-10SI	8C 8C1 8P3 8S2	Industrial (-40°C to 85°C)
5	4000	3.0	5000	AT25HP256-10CC-2.7 AT25HP256C1-10CC-2.7 AT25HP256-10PC-2.7 AT25HP256W-10SC-2.7	8C 8C1 8P3 8S2	Commercial (0°C to 70°C)
	4000	3.0	5000	AT25HP256-10CI-2.7 AT25HP256C1-10CI-2.7 AT25HP256-10PI-2.7 AT25HP256W-10SI-2.7	8C 8C1 8P3 8S2	Industrial (-40°C to 85°C)
TBD	TBD	TBD	TBD	AT25HP256-10CC-1.8 AT25HP256C1-10CC-1.8 AT25HP256-10PC-1.8 AT25HP256W-10SC-1.8	8C 8C1 8P3 8S2	Commercial (0°C to 70°C)
	TBD	TBD	TBD	AT25HP256-10CI-1.8 AT25HP256C1-10CI-1.8 AT25HP256-10PI-1.8 AT25HP256W-10SI-1.8	8C 8C1 8P3 8S2	Industrial (-40°C to 85°C)

Package Type	
<b>8C</b>	8-Lead, 0.230" Wide, Leadless Array Package (LAP)
<b>8C1</b>	8-Lead, 0.300" Wide, Leadless Array Package (LAP)
<b>8P3</b>	8-Lead, 0.300" Wide, Plastic Dual In-line Package (PDIP)
<b>8S2</b>	8-Lead, 0.300" Wide, Plastic Gull Wing Small Outline Package (EIAJ SOIC)
Options	
<b>Blank</b>	Standard Device (4.5V to 5.5V)
<b>-2.7</b>	Low Voltage (2.7V to 5.5V)
<b>-1.8</b>	Low Voltage (1.8V to 3.6V)



## AT25HP512 Ordering Information

$t_{WC}$ (max) (ms)	$I_{CC}$ (max) ( $\mu A$ )	$I_{SB}$ (max) ( $\mu A$ )	$f_{MAX}$ (kHz)	Ordering Code	Package	Operation Range
5	8000	7.0	10000	AT25HP512C1-10CC AT25HP512-10PC	8C1 8P3	Commercial (0°C to 70°C)
	8000	7.0	10000	AT25HP512C1-10CI AT25HP512-10PI	8C1 8P3	Industrial (-40°C to 85°C)
5	4000	3.0	5000	AT25HP512C1-10CC-2.7 AT25HP512-10PC-2.7	8C1 8P3	Commercial (0°C to 70°C)
	4000	3.0	5000	AT25HP512C1-10CI-2.7 AT25HP512-10PI-2.7	8C1 8P3	Industrial (-40°C to 85°C)
TBD	TBD	TBD	TBD	AT25HP512C1-10CC-1.8 AT25HP512-10PC-1.8	8C1 8P3	Commercial (0°C to 70°C)
	TBD	TBD	TBD	AT25HP512C1-10CI-1.8 AT25HP512-10PI-1.8	8C1 8P3	Industrial (-40°C to 85°C)

Package Type	
<b>8C1</b>	8-Lead, 0.300" Wide, Leadless Array Package (LAP)
<b>8P3</b>	8-Lead, 0.300" Wide, Plastic Dual In-line Package (PDIP)
Options	
<b>Blank</b>	Standard Device (4.5V to 5.5V)
<b>-2.7</b>	Low Voltage (2.7V to 5.5V)
<b>-1.8</b>	Low Voltage (1.8V to 3.6V)

Packaging Information

**8C**, 8-Lead, 0.230" Wide, Leadless Array Package (LAP)  
Dimensions in Inches and (Millimeters)

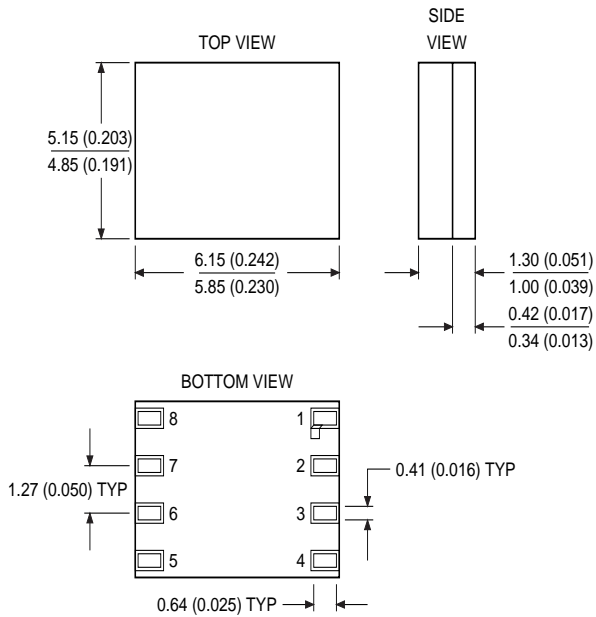

**8C1**, 8-Lead, 0.300" Wide, Leadless Array Package (LAP)  
Dimensions in Inches and (Millimeters)

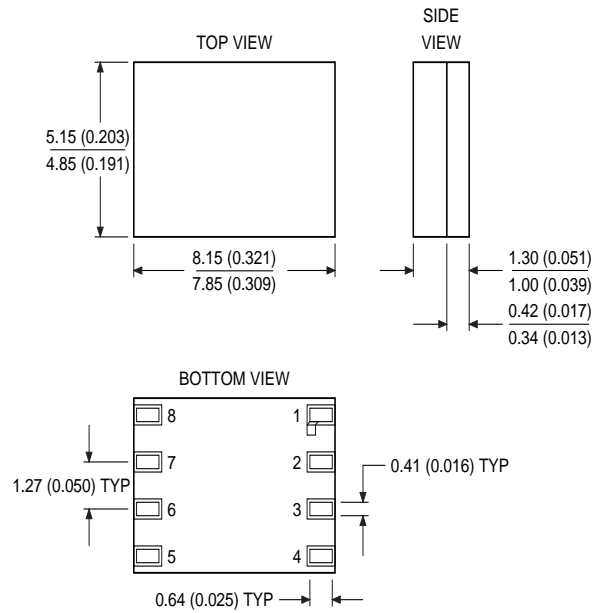

**8P3**, 8-Lead, 0.300" Wide, Plastic Dual In-line Package (PDIP) Dimensions in Inches and (Millimeters) JEDEC STANDARD MS-001 BA

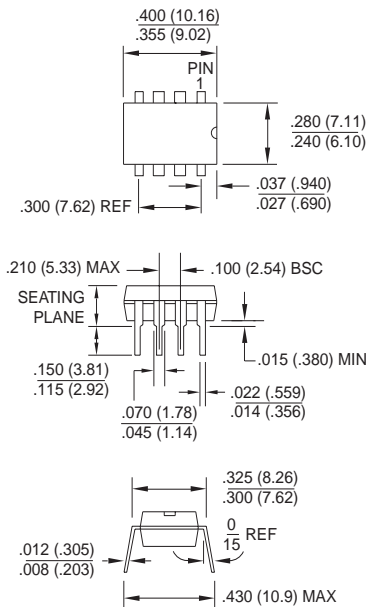

**8S2**, 8-Lead, 0.200" Wide, Plastic Gull Wing Small Outline (EIAJ SOIC) Dimensions in Inches and (Millimeters)

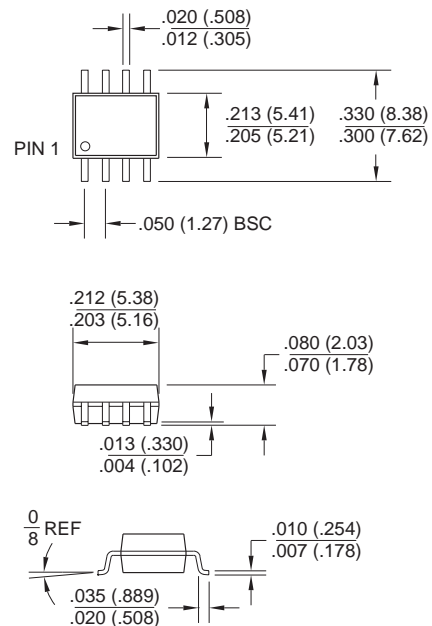

Copyright © Each Manufacturing Company.

All Datasheets cannot be modified without permission.

This datasheet has been download from :

[www.AllDataSheet.com](http://www.AllDataSheet.com)

100% Free DataSheet Search Site.

Free Download.

No Register.

Fast Search System.

[www.AllDataSheet.com](http://www.AllDataSheet.com)