

DATA SHEET

74LV132

Quad 2-input NAND Schmitt-trigger

Product specification
Supersedes data of 1997 Feb 04
IC24 Data Handbook

1998 Apr 28

Quad 2-input NAND Schmitt-trigger

74LV132

FEATURES

- Wide operating voltage: 1.0 to 5.5V
- Optimized for Low Voltage applications: 1.0 to 3.6V
- Accepts TTL input levels between $V_{CC} = 2.7V$ and $V_{CC} = 3.6V$
- Typical V_{OLP} (output ground bounce) $< 0.8V$ @ $V_{CC} = 3.3V$, $T_{amb} = 25^{\circ}C$
- Typical V_{OHV} (output V_{OH} undershoot) $> 2V$ @ $V_{CC} = 3.3V$, $T_{amb} = 25^{\circ}C$
- Output capability: standard
- I_{CC} category: SSI

APPLICATIONS

- Wave and pulse shapers
- Astable multivibrators
- Monostable multivibrators

DESCRIPTION

The 74LV132 is a low-voltage Si-gate CMOS device and is pin and function compatible with 74HC/HCT132.

The 74LV132 contains four 2-input NAND gates which accept standard input signals. They are capable of transforming slowly changing input signals into sharply defined, jitter-free output signals.

The gate switches at different points for positive and negative-going signals. The difference between the positive voltage V_{T+} and the negative voltage V_{T-} is defined as the hysteresis voltage V_H .

QUICK REFERENCE DATA

$GND = 0V$; $T_{amb} = 25^{\circ}C$; $t_r = t_f \leq 2.5$ ns

SYMBOL	PARAMETER	CONDITIONS	TYPICAL	UNIT
t_{PHL}/t_{PLH}	Propagation delay nA, nB to nY	$C_L = 15pF$ $V_{CC} = 3.3V$	10	ns
C_I	Input capacitance		3.5	pF
C_{PD}	Power dissipation capacitance per gate	Notes 1 and 2	24	pF

NOTES:

1. C_{PD} is used to determine the dynamic power dissipation (P_D in μW)
 $P_D = C_{PD} \times V_{CC}^2 \times f_i + \sum (C_L \times V_{CC}^2 \times f_o)$ where:
 f_i = input frequency in MHz; C_L = output load capacitance in pF;
 f_o = output frequency in MHz; V_{CC} = supply voltage in V;
 $\sum (C_L \times V_{CC}^2 \times f_o)$ = sum of the outputs.
2. The condition is $V_I = GND$ to V_{CC}

ORDERING INFORMATION

PACKAGES	TEMPERATURE RANGE	OUTSIDE NORTH AMERICA	NORTH AMERICA	PKG. DWG. #
14-Pin Plastic DIL	$-40^{\circ}C$ to $+125^{\circ}C$	74LV132 N	74LV132 N	SOT27-1
14-Pin Plastic SO	$-40^{\circ}C$ to $+125^{\circ}C$	74LV132 D	74LV132 D	SOT108-1
14-Pin Plastic SSOP Type II	$-40^{\circ}C$ to $+125^{\circ}C$	74LV132 DB	74LV132 DB	SOT337-1
14-Pin Plastic TSSOP Type I	$-40^{\circ}C$ to $+125^{\circ}C$	74LV132 PW	74LV132PW DH	SOT402-1

PIN DESCRIPTION

PIN NUMBER	SYMBOL	FUNCTION
1, 4, 9, 12	1A to 4A	Data inputs
2, 5, 10, 13	1B to 4B	Data inputs
3, 6, 8, 11	1Y to 4Y	Data outputs
7	GND	Ground (0V)
14	V_{CC}	Positive supply voltage

FUNCTION TABLE

INPUTS		OUTPUT
nA	nB	nY
L	L	H
L	H	H
H	L	H
H	H	L

NOTES:

H = HIGH voltage level
L = LOW voltage level

Quad 2-input NAND Schmitt-trigger

74LV132

PIN CONFIGURATION

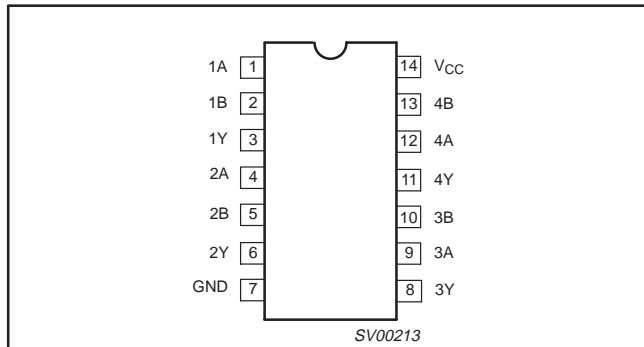

LOGIC SYMBOL

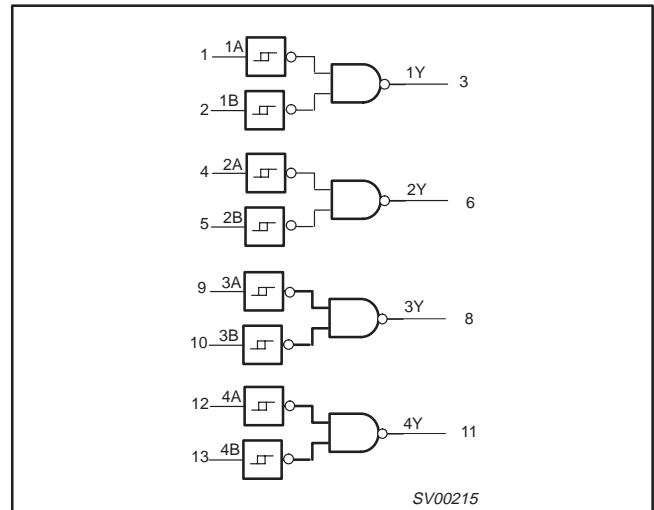

LOGIC SYMBOL (IEEE/IEC)

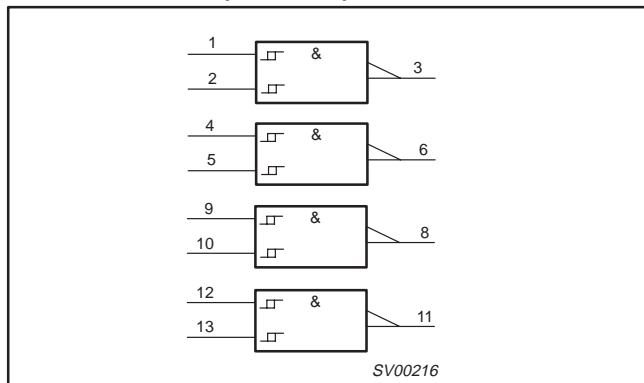

LOGIC DIAGRAM

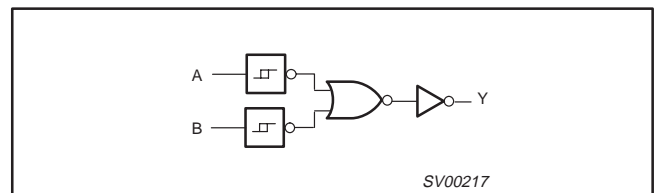

RECOMMENDED OPERATING CONDITIONS

SYMBOL	PARAMETER	CONDITIONS	MIN	TYP	MAX	UNIT
V_{CC}	DC supply voltage	See Note1	1.0	3.3	5.5	V
V_I	Input voltage		0	–	V_{CC}	V
V_O	Output voltage		0	–	V_{CC}	V
T_{amb}	Operating ambient temperature range in free air	See DC and AC characteristics	–40 –40		+85 +125	°C
t_r, t_f	Input rise and fall times except for Schmitt-trigger inputs	$V_{CC} = 1.0V$ to $2.0V$ $V_{CC} = 2.0V$ to $2.7V$ $V_{CC} = 2.7V$ to $3.6V$ $V_{CC} = 3.6V$ to $5.5V$	– – – –	– – – –	500 200 100 50	ns/V

NOTE:

1. The LV is guaranteed to function down to $V_{CC} = 1.0V$ (input levels GND or V_{CC}); DC characteristics are guaranteed from $V_{CC} = 1.2V$ to $V_{CC} = 5.5V$.

Quad 2-input NAND Schmitt-trigger

74LV132

ABSOLUTE MAXIMUM RATINGS^{1, 2}

In accordance with the Absolute Maximum Rating System (IEC 134).

Voltages are referenced to GND (ground = 0V).

SYMBOL	PARAMETER	CONDITIONS	RATING	UNIT
V_{CC}	DC supply voltage		-0.5 to +7.0	V
$\pm I_{IK}$	DC input diode current	$V_I < -0.5$ or $V_I > V_{CC} + 0.5V$	20	mA
$\pm I_{OK}$	DC output diode current	$V_O < -0.5$ or $V_O > V_{CC} + 0.5V$	50	mA
$\pm I_O$	DC output source or sink current – standard outputs	$-0.5V < V_O < V_{CC} + 0.5V$	25	mA
$\pm I_{GND},$ $\pm I_{CC}$	DC V_{CC} or GND current for types with – standard outputs		50	mA
T_{stg}	Storage temperature range		-65 to +150	°C
P_{TOT}	Power dissipation per package – plastic DIL – plastic mini-pack (SO) – plastic shrink mini-pack (SSOP and TSSOP)	for temperature range: -40 to +125°C above +70°C derate linearly with 12 mW/K above +70°C derate linearly with 8 mW/K above +60°C derate linearly with 5.5 mW/K	750 500 400	mW

NOTES:

- Stresses beyond those listed may cause permanent damage to the device. These are stress ratings only and functional operation of the device at these or any other conditions beyond those indicated under “recommended operating conditions” is not implied. Exposure to absolute-maximum-rated conditions for extended periods may affect device reliability.
- The input and output voltage ratings may be exceeded if the input and output current ratings are observed.

DC CHARACTERISTICS

Over recommended operating conditions. Voltages are referenced to GND (ground = 0V).

SYMBOL	PARAMETER	TEST CONDITIONS	LIMITS					UNIT
			-40°C to +85°C			-40°C to +125°C		
			MIN	TYP ¹	MAX	MIN	MAX	
V_{IH}	HIGH level Input voltage	$V_{CC} = 1.2V$	0.9			0.9		V
		$V_{CC} = 2.0V$	1.4			1.4		
		$V_{CC} = 2.7$ to $3.6V$	2.0			2.0		
		$V_{CC} = 4.5$ to $5.5V$	$0.7 \cdot V_{CC}$			$0.7 \cdot V_{CC}$		
V_{IL}	LOW level Input voltage	$V_{CC} = 1.2V$			0.3		0.3	V
		$V_{CC} = 2.0V$			0.6		0.6	
		$V_{CC} = 2.7$ to $3.6V$			0.8		0.8	
		$V_{CC} = 4.5$ to $5.5V$			$0.3 \cdot V_{CC}$		$0.3 \cdot V_{CC}$	
V_{OH}	HIGH level output voltage; all outputs	$V_{CC} = 1.2V; V_I = V_{IH}$ or $V_{IL}; -I_O = 100\mu A$		1.2				V
		$V_{CC} = 2.0V; V_I = V_{IH}$ or $V_{IL}; -I_O = 100\mu A$	1.8	2.0		1.8		
		$V_{CC} = 2.7V; V_I = V_{IH}$ or $V_{IL}; -I_O = 100\mu A$	2.5	2.7		2.5		
		$V_{CC} = 3.0V; V_I = V_{IH}$ or $V_{IL}; -I_O = 100\mu A$	2.8	3.0		2.8		
		$V_{CC} = 4.5V; V_I = V_{IH}$ or $V_{IL}; -I_O = 100\mu A$	4.3	4.5		4.3		
V_{OH}	HIGH level output voltage; STANDARD outputs	$V_{CC} = 3.0V; V_I = V_{IH}$ or $V_{IL}; -I_O = 6mA$	2.40	2.82		2.20		V
		$V_{CC} = 4.5V; V_I = V_{IH}$ or $V_{IL}; -I_O = 12mA$	3.60	4.20		3.50		
V_{OL}	LOW level output voltage; all outputs	$V_{CC} = 1.2V; V_I = V_{IH}$ or $V_{IL}; I_O = 100\mu A$		0				V
		$V_{CC} = 2.0V; V_I = V_{IH}$ or $V_{IL}; I_O = 100\mu A$		0	0.2		0.2	
		$V_{CC} = 2.7V; V_I = V_{IH}$ or $V_{IL}; I_O = 100\mu A$		0	0.2		0.2	
		$V_{CC} = 3.0V; V_I = V_{IH}$ or $V_{IL}; I_O = 100\mu A$		0	0.2		0.2	
		$V_{CC} = 4.5V; V_I = V_{IH}$ or $V_{IL}; I_O = 100\mu A$		0	0.2		0.2	

Quad 2-input NAND Schmitt-trigger

74LV132

DC CHARACTERISTICS (Continued)

Over recommended operating conditions. Voltages are referenced to GND (ground = 0V).

SYMBOL	PARAMETER	TEST CONDITIONS	LIMITS				UNIT	
			-40°C to +85°C		-40°C to +125°C			
V _{OL}	LOW level output voltage; STANDARD outputs	V _{CC} = 3.0V; V _I = V _{IH} or V _{IL} ; I _O = 6mA		0.25	0.40		0.50	V
		V _{CC} = 4.5V; V _I = V _{IH} or V _{IL} ; I _O = 12mA		0.35	0.55		0.65	
I _I	Input leakage current	V _{CC} = 5.5V; V _I = V _{CC} or GND			1.0		1.0	μA
I _{CC}	Quiescent supply current; SSI	V _{CC} = 5.5V; V _I = V _{CC} or GND; I _O = 0			20.0		40	μA
ΔI _{CC}	Additional quiescent supply current per input	V _{CC} = 2.7V to 3.6V; V _I = V _{CC} - 0.6V			500		850	μA

NOTE:1. All typical values are measured at T_{amb} = 25°C.**TRANSFER CHARACTERISTICS**

Voltages are referenced to GND = 0V.

SYMBOL	PARAMETER	WAVEFORM	CONDITION	LIMITS					UNIT
				-40 to +85°C			-40 to +125°C		
				V _{CC} (V)	MIN	TYP ¹	MAX	MIN	
V _{T+}	Positive going threshold	Figures 1 and 2	1.2	–	0.70	–	–	–	V
			2.0	0.8	1.10	1.4	0.8	1.4	
			2.7	1.0	1.45	2.0	1.0	2.0	
			3.0	1.2	1.60	2.2	1.2	2.2	
			3.6	1.5	1.95	2.4	1.5	2.4	
			4.5	1.7	2.50	3.2	1.7	3.2	
			5.5	2.1	3.00	3.9	2.1	3.9	
V _{T-}	Negative going threshold	Figures 1 and 2	1.2	–	0.34	–	–	–	V
			2.0	0.3	0.65	0.9	0.3	0.9	
			2.7	0.4	0.90	1.4	0.4	1.4	
			3.0	0.6	1.05	1.5	0.6	1.5	
			3.6	0.8	1.30	1.8	0.8	1.8	
			4.5	0.9	1.60	2.0	0.9	2.0	
			5.5	1.2	2.00	2.6	1.2	2.6	
V _H	Hysteresis (V _{T+} - V _{T-})	Figures 1 and 2	1.2	–	0.30	–	–	–	V
			2.0	0.2	0.55	0.8	0.2	0.8	
			2.7	0.3	0.60	1.1	0.3	1.1	
			3.0	0.4	0.65	1.2	0.4	1.2	
			3.6	0.4	0.70	1.2	0.4	1.2	
			4.5	0.4	0.80	1.4	0.4	1.4	
			5.5	0.6	1.00	1.5	0.6	1.5	

NOTE:1. Unless otherwise stated, all typical values are at T_{amb} = 25°C.

Quad 2-input NAND Schmitt-trigger

74LV132

AC CHARACTERISTICS

GND = 0V; $t_r = t_f = 2.5\text{ns}$; $C_L = 50\text{pF}$

SYMBOL	PARAMETER	WAVEFORM	CONDITION	LIMITS					UNIT
				-40 to +85°C			-40 to +125°C		
				MIN	TYP ¹	MAX	MIN	MAX	
t_{PHL}/t_{PLH}	Propagation delay nA, nB, to nY	Figure 6	$V_{CC}(V)$						ns
			1.2	–	65	–	–	–	
			2.0	–	18	34	–	43	
			2.7	–	15	24	–	30	
			3.0 to 3.6	–	12 ²	20	–	25	
4.5 to 5.5	–	9.0 ²	14	–	17				

NOTES:

1. Unless otherwise stated, all typical values are at $T_{amb} = 25^\circ\text{C}$.
2. Typical value measured at $V_{CC} = 3.3\text{V}$.
3. Typical value measured at $V_{CC} = 5.0\text{V}$.

TRANSFER CHARACTERISTIC WAVEFORMS

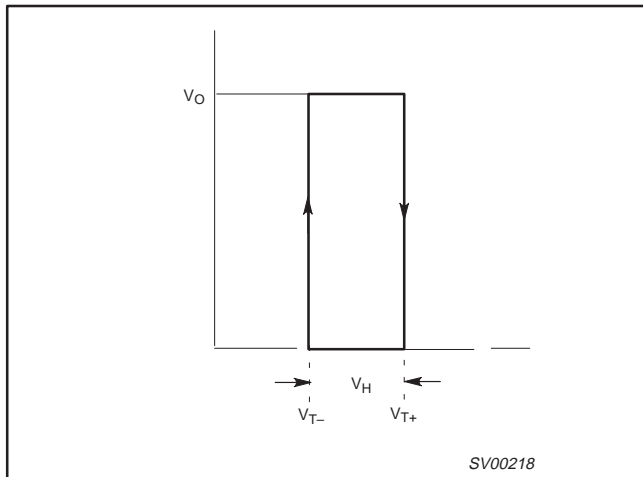

Figure 1. Transfer characteristic.

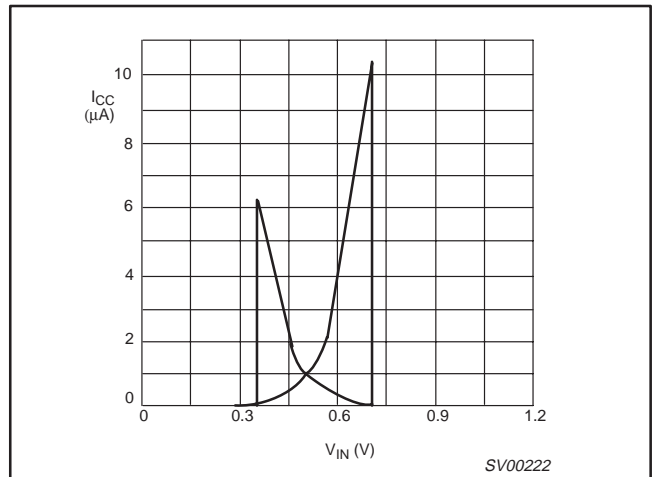

Figure 3. Typical LV132 transfer characteristics; $V_{CC} = 1.2\text{V}$.

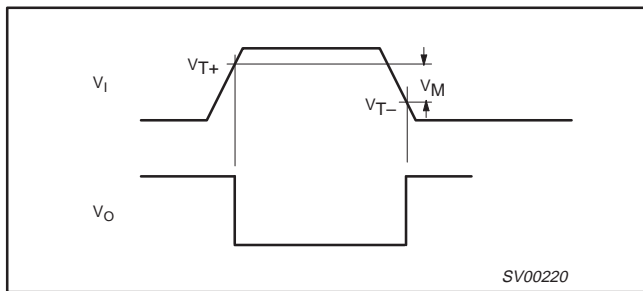

Figure 2. Definition of V_{T+} , V_{T-} and V_H ; where V_{T+} and V_{T-} are between limits of 20% and 70%.

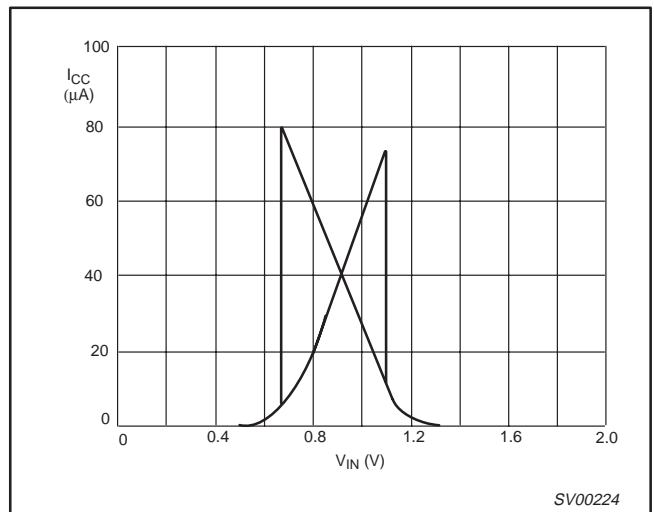

Figure 4. Typical LV132 transfer characteristics; $V_{CC} = 2.0\text{V}$.

Quad 2-input NAND Schmitt-trigger

74LV132

TRANSFER CHARACTERISTIC WAVEFORMS (Continued)

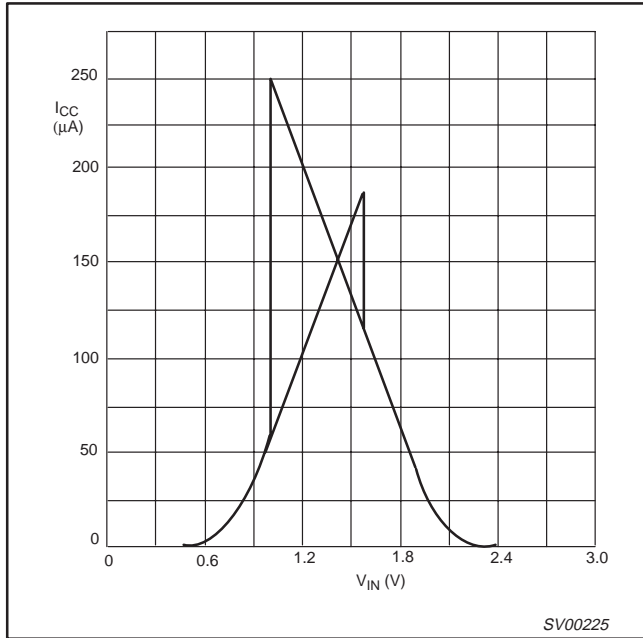

Figure 5. Typical LV132 transfer characteristics; $V_{CC} = 3.0V$.

AC WAVEFORMS

$V_M = 1.5V$ at $V_{CC} \geq 2.7V \leq 3.6V$

$V_M = 0.5V * V_{CC}$ at $V_{CC} < 2.7V$ and $\geq 4.5V$

V_{OL} and V_{OH} are the typical output voltage drop that occur with the output load.

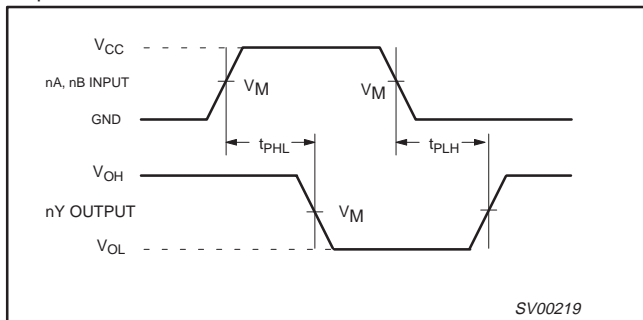

Figure 6. Input (nA, nB) to output (nY) propagation delays.

TEST CIRCUIT

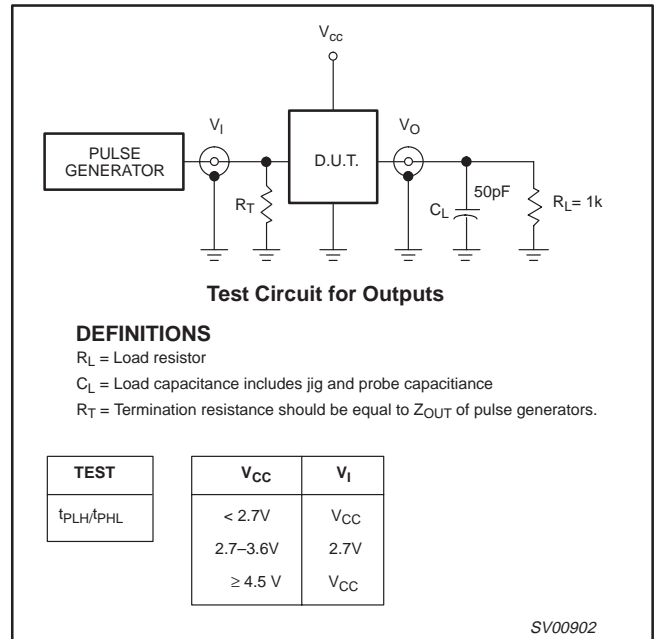

Figure 7. Load circuitry for switching times.

Quad 2-input NAND Schmitt-trigger

74LV132

DIP14: plastic dual in-line package; 14 leads (300 mil)

SOT27-1

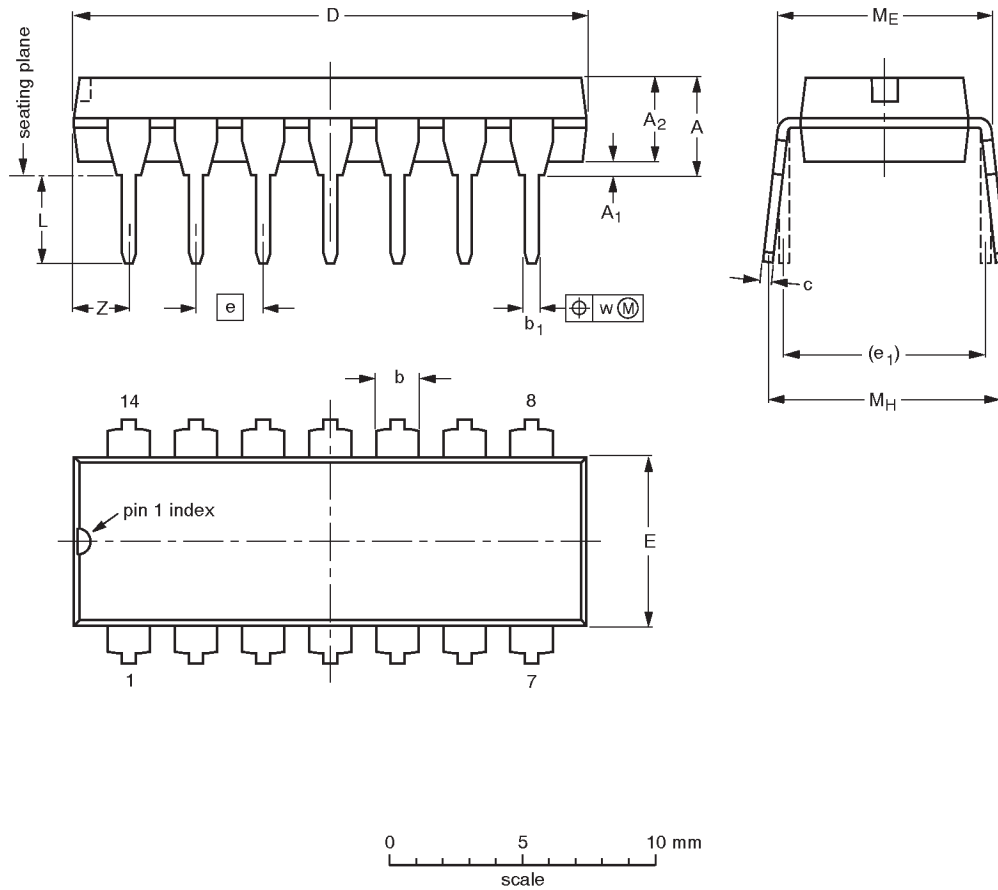

DIMENSIONS (inch dimensions are derived from the original mm dimensions)

UNIT	A max.	A ₁ min.	A ₂ max.	b	b ₁	c	D ⁽¹⁾	E ⁽¹⁾	e	e ₁	L	M _E	M _H	w	Z ⁽¹⁾ max.
mm	4.2	0.51	3.2	1.73 1.13	0.53 0.38	0.36 0.23	19.50 18.55	6.48 6.20	2.54	7.62	3.60 3.05	8.25 7.80	10.0 8.3	0.254	2.2
inches	0.17	0.020	0.13	0.068 0.044	0.021 0.015	0.014 0.009	0.77 0.73	0.26 0.24	0.10	0.30	0.14 0.12	0.32 0.31	0.39 0.33	0.01	0.087

Note

1. Plastic or metal protrusions of 0.25 mm maximum per side are not included.

OUTLINE VERSION	REFERENCES			EUROPEAN PROJECTION	ISSUE DATE
	IEC	JEDEC	EIAJ		
SOT27-1	050G04	MO-001AA			92-11-17 95-03-11

Quad 2-input NAND Schmitt-trigger

74LV132

SO14: plastic small outline package; 14 leads; body width 3.9 mm

SOT108-1

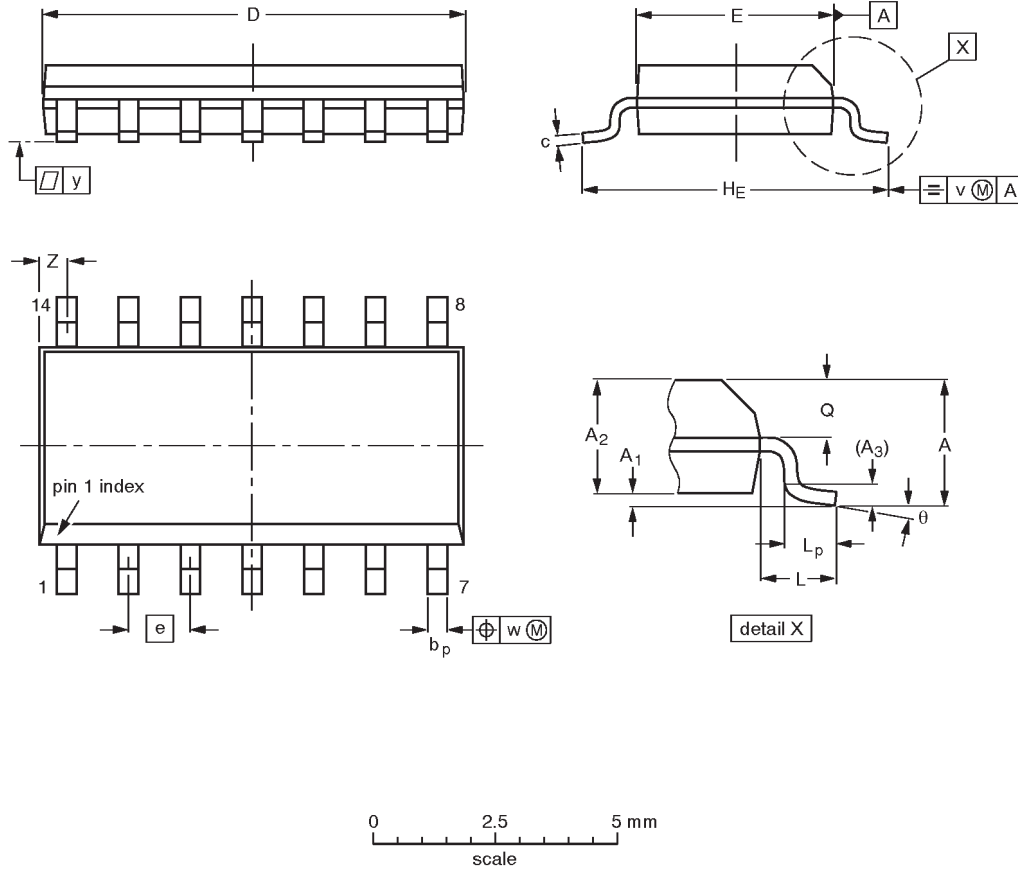

DIMENSIONS (inch dimensions are derived from the original mm dimensions)

UNIT	A max.	A ₁	A ₂	A ₃	b _p	c	D ⁽¹⁾	E ⁽¹⁾	e	H _E	L	L _p	Q	v	w	y	Z ⁽¹⁾	θ
mm	1.75	0.25 0.10	1.45 1.25	0.25	0.49 0.36	0.25 0.19	8.75 8.55	4.0 3.8	1.27	6.2 5.8	1.05	1.0 0.4	0.7 0.6	0.25	0.25	0.1	0.7 0.3	8° 0°
inches	0.069	0.0098 0.0039	0.057 0.049	0.01	0.019 0.014	0.0098 0.0075	0.35 0.34	0.16 0.15	0.050	0.24 0.23	0.041	0.039 0.016	0.028 0.024	0.01	0.01	0.004	0.028 0.012	

Note

1. Plastic or metal protrusions of 0.15 mm maximum per side are not included.

OUTLINE VERSION	REFERENCES				EUROPEAN PROJECTION	ISSUE DATE
	IEC	JEDEC	EIAJ			
SOT108-1	076E06S	MS-012AB				91-08-13 95-01-23

Quad 2-input NAND Schmitt-trigger

74LV132

SSOP14: plastic shrink small outline package; 14 leads; body width 5.3 mm

SOT337-1

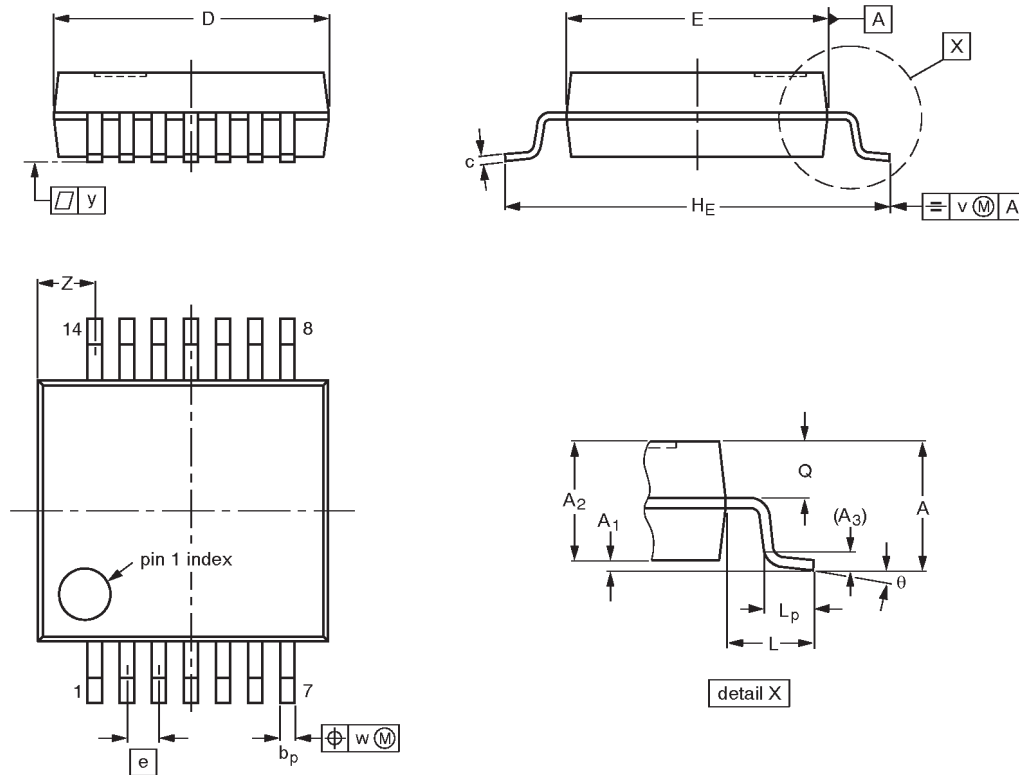

DIMENSIONS (mm are the original dimensions)

UNIT	A max.	A ₁	A ₂	A ₃	b _p	c	D ⁽¹⁾	E ⁽¹⁾	e	H _E	L	L _p	Q	v	w	y	Z ⁽¹⁾	θ
mm	2.0	0.21 0.05	1.80 1.65	0.25	0.38 0.25	0.20 0.09	6.4 6.0	5.4 5.2	0.65	7.9 7.6	1.25	1.03 0.63	0.9 0.7	0.2	0.13	0.1	1.4 0.9	8° 0°

Note

1. Plastic or metal protrusions of 0.25 mm maximum per side are not included.

OUTLINE VERSION	REFERENCES				EUROPEAN PROJECTION	ISSUE DATE
	IEC	JEDEC	EIAJ			
SOT337-1		MO-150AB				95-02-04 96-01-18

Quad 2-input NAND Schmitt-trigger

74LV132

TSSOP14: plastic thin shrink small outline package; 14 leads; body width 4.4 mm

SOT402-1

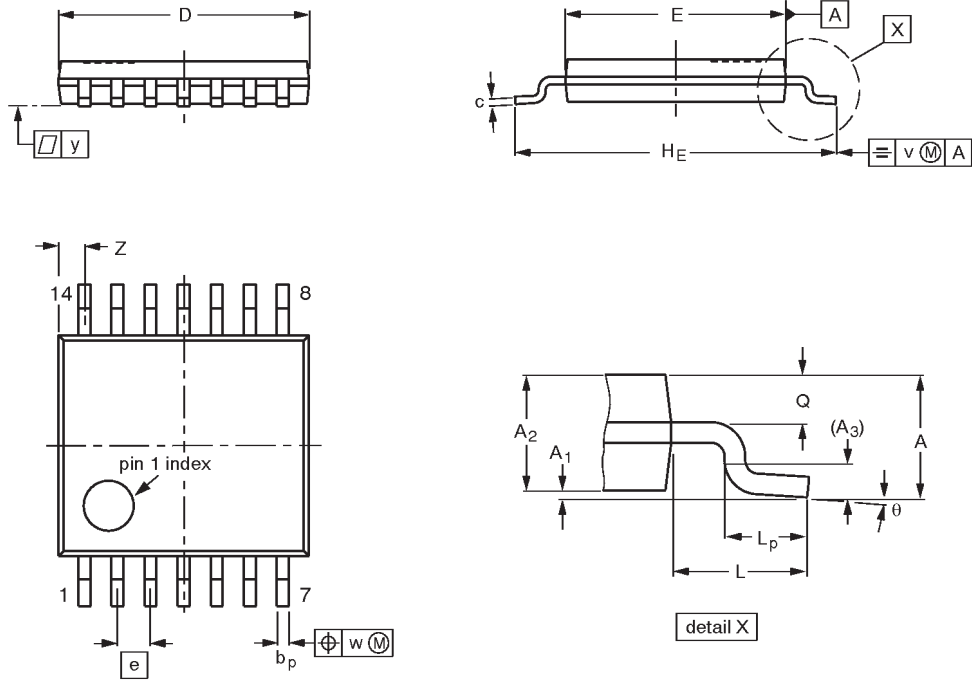

DIMENSIONS (mm are the original dimensions)

UNIT	A max.	A ₁	A ₂	A ₃	b _p	c	D ⁽¹⁾	E ⁽²⁾	e	H _E	L	L _p	Q	v	w	y	Z ⁽¹⁾	θ
mm	1.10	0.15 0.05	0.95 0.80	0.25	0.30 0.19	0.2 0.1	5.1 4.9	4.5 4.3	0.65	6.6 6.2	1.0	0.75 0.50	0.4 0.3	0.2	0.13	0.1	0.72 0.38	8° 0°

Notes

1. Plastic or metal protrusions of 0.15 mm maximum per side are not included.
2. Plastic interlead protrusions of 0.25 mm maximum per side are not included.

OUTLINE VERSION	REFERENCES				EUROPEAN PROJECTION	ISSUE DATE
	IEC	JEDEC	EIAJ			
SOT402-1		MO-153				-94-07-12- 95-04-04

Quad 2-input NAND Schmitt-trigger

74LV132

Data sheet status

Data sheet status	Product status	Definition [1]
Objective specification	Development	This data sheet contains the design target or goal specifications for product development. Specification may change in any manner without notice.
Preliminary specification	Qualification	This data sheet contains preliminary data, and supplementary data will be published at a later date. Philips Semiconductors reserves the right to make changes at any time without notice in order to improve design and supply the best possible product.
Product specification	Production	This data sheet contains final specifications. Philips Semiconductors reserves the right to make changes at any time without notice in order to improve design and supply the best possible product.

[1] Please consult the most recently issued datasheet before initiating or completing a design.

Definitions

Short-form specification — The data in a short-form specification is extracted from a full data sheet with the same type number and title. For detailed information see the relevant data sheet or data handbook.

Limiting values definition — Limiting values given are in accordance with the Absolute Maximum Rating System (IEC 134). Stress above one or more of the limiting values may cause permanent damage to the device. These are stress ratings only and operation of the device at these or at any other conditions above those given in the Characteristics sections of the specification is not implied. Exposure to limiting values for extended periods may affect device reliability.

Application information — Applications that are described herein for any of these products are for illustrative purposes only. Philips Semiconductors make no representation or warranty that such applications will be suitable for the specified use without further testing or modification.

Disclaimers

Life support — These products are not designed for use in life support appliances, devices or systems where malfunction of these products can reasonably be expected to result in personal injury. Philips Semiconductors customers using or selling these products for use in such applications do so at their own risk and agree to fully indemnify Philips Semiconductors for any damages resulting from such application.

Right to make changes — Philips Semiconductors reserves the right to make changes, without notice, in the products, including circuits, standard cells, and/or software, described or contained herein in order to improve design and/or performance. Philips Semiconductors assumes no responsibility or liability for the use of any of these products, conveys no license or title under any patent, copyright, or mask work right to these products, and makes no representations or warranties that these products are free from patent, copyright, or mask work right infringement, unless otherwise specified.

Philips Semiconductors
811 East Arques Avenue
P.O. Box 3409
Sunnyvale, California 94088-3409
Telephone 800-234-7381

© Copyright Philips Electronics North America Corporation 1998
All rights reserved. Printed in U.S.A.

print code

Date of release: 08-98

Document order number:

9397-750-04422

Let's make things better.

Copyright © Each Manufacturing Company.

All Datasheets cannot be modified without permission.

This datasheet has been download from :

www.AllDataSheet.com

100% Free DataSheet Search Site.

Free Download.

No Register.

Fast Search System.

www.AllDataSheet.com