

DATA SHEET

74LV259

8-bit addressable latch

Product specification
Supersedes data of 1997 Jun 06
IC24 Data Handbook

1998 May 20

8-bit addressable latch

74LV259

FEATURES

- Optimized for low voltage applications: 1.0 to 3.6 V
- Accepts TTL input levels between $V_{CC} = 2.7$ V and $V_{CC} = 3.6$ V
- Typical V_{OLP} (output ground bounce) < 0.8 V at $V_{CC} = 3.3$ V, $T_{amb} = 25^{\circ}\text{C}$
- Typical V_{OHV} (output V_{OH} undershoot) > 2 V at $V_{CC} = 3.3$ V, $T_{amb} = 25^{\circ}\text{C}$
- Combines demultiplexer and 8-bit latch
- Serial-to-parallel capability
- Output from each storage bit available
- Random (addressable) data entry
- Easily expandable
- Common reset input
- Useful as a 3-to-8 active HIGH decoder
- Output capability: standard
- I_{CC} category: MSI

DESCRIPTION

The 74LV259 is a low-voltage CMOS device and is pin and function compatible with 74HC/HCT259.

The 74LV259 is a high-speed 8-bit addressable latch designed for general purpose storage applications in digital systems. The 74LV259 is a multifunction device capable of storing single-line data in eight addressable latches, and also 3-to-8 decoder and demultiplexer, with active HIGH outputs (Q_0 to Q_7), functions are available. The 74LV259 also incorporate an active LOW common reset (\overline{MR}) for resetting all latches, as well as an active LOW enable input (\overline{LE}). The 74LV259 has four modes of operation as shown in the mode select table. In the addressable latch mode, data on the data line (D) is written into the addressed latch. The addressed latch will follow the data input with all non-addressed latches remaining in their previous states. In the memory mode, all latches remain in their previous states and are unaffected by the data or address inputs.

In the 3-to-8 decoding or demultiplexing mode, the addressed output follows the state of the D input with all other outputs in the LOW state. In the reset mode all outputs are LOW and unaffected by the address (A_0 to A_2) and data (D) input. When operating the 74LV259 as an addressable latch, changing more than one bit of address could impose a transient-wrong address. Therefore, this should only be done while in the memory mode. The mode select table summarizes the operations of the 74LV259.

QUICK REFERENCE DATA

$GND = 0$ V; $T_{amb} = 25^{\circ}\text{C}$; $t_r = t_f \leq 2.5$ ns

SYMBOL	PARAMETER	CONDITIONS	TYPICAL	UNIT
t_{PHL}/t_{PLH}	Propagation delay D, A_n to Q_n \overline{LE} to Q_n \overline{MR} to Q_n	$C_L = 15$ pF; $V_{CC} = 3.3$ V	17 16 14	ns
C_I	Input capacitance		3.5	pF
C_{PD}	Power dissipation capacitance per latch	$V_I = GND$ to V_{CC}^1	19	pF

NOTE:

- C_{PD} is used to determine the dynamic power dissipation (P_D in μW)
 $P_D = C_{PD} \times V_{CC}^2 \times f_i + \sum (C_L \times V_{CC}^2 \times f_o)$ where:
 f_i = input frequency in MHz; C_L = output load capacity in pF;
 f_o = output frequency in MHz; V_{CC} = supply voltage in V;
 $\sum (C_L \times V_{CC}^2 \times f_o)$ = sum of the outputs.

ORDERING INFORMATION

PACKAGES	TEMPERATURE RANGE	OUTSIDE NORTH AMERICA	NORTH AMERICA	PKG. DWG. #
16-Pin Plastic DIL	-40°C to $+125^{\circ}\text{C}$	74LV259 N	74LV259 N	SOT38-4
16-Pin Plastic SO	-40°C to $+125^{\circ}\text{C}$	74LV259 D	74LV259 D	SOT109-1
16-Pin Plastic SSOP Type II	-40°C to $+125^{\circ}\text{C}$	74LV259 DB	74LV259 DB	SOT338-1
16-Pin Plastic TSSOP Type I	-40°C to $+125^{\circ}\text{C}$	74LV259 PW	74LV259PW DH	SOT403-1

8-bit addressable latch

74LV259

PIN CONFIGURATION

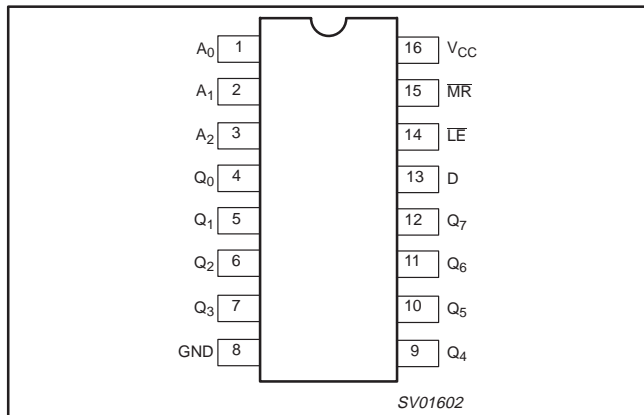

PIN DESCRIPTION

PIN NUMBER	SYMBOL	FUNCTION
1, 2, 3	A ₀ to A ₂	Address inputs
4, 5, 6, 7, 9, 10, 11, 12	Q ₀ to Q ₇	Latch outputs
8	GND	Ground (0 V)
13	D	Data input
14	\overline{LE}	Latch enable input (active LOW)
15	\overline{MR}	Conditional reset input (active LOW)
16	V _{CC}	Positive supply voltage

LOGIC SYMBOL

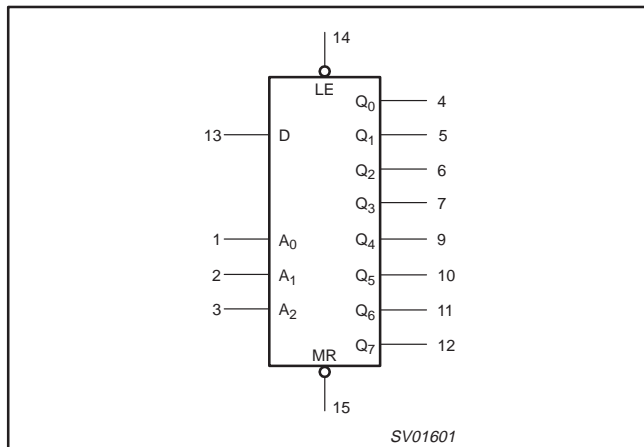

LOGIC SYMBOL (IEEE/IEC)

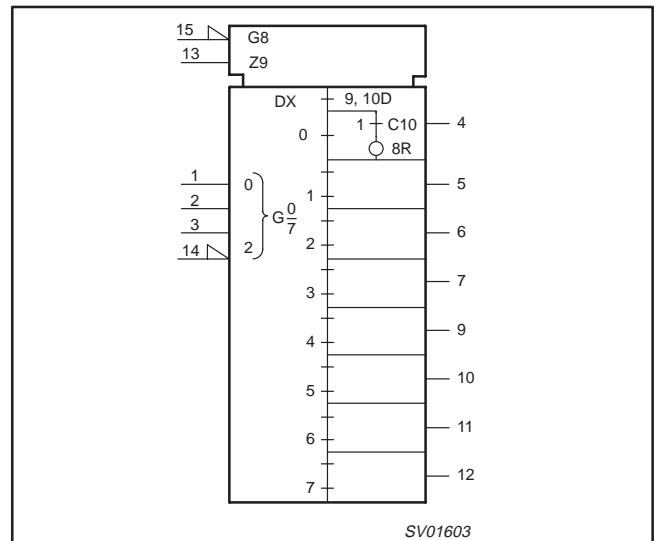

FUNCTIONAL DIAGRAM

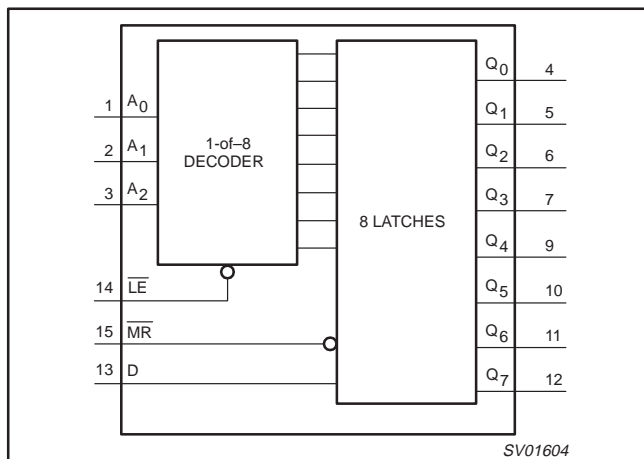

MODE SELECT TABLE

LE	MR	MODE
L	H	Addressable latch
H	H	Memory
L	L	Active HIGH 8-channel demultiplexer
H	L	Reset

8-bit addressable latch

74LV259

FUNCTION TABLE

OPERATING MODES	INPUTS						OUTPUTS							
	MR	LE	D	A ₀	A ₁	A ₂	Q ₀	Q ₁	Q ₂	Q ₃	Q ₄	Q ₅	Q ₆	Q ₇
Master reset	L	H	X	X	X	X	L	L	L	L	L	L	L	L
Demultiplex (active HIGH) decoder (when D = H)	L	L	d	L	L	L	Q=d	L	L	L	L	L	L	L
	L	L	d	H	L	L	L	Q=d	L	L	L	L	L	L
	L	L	d	L	H	L	L	L	Q=d	L	L	L	L	L
	L	L	d	H	H	L	L	L	L	Q=d	L	L	L	L
	L	L	d	L	L	H	L	L	L	L	Q=d	L	L	L
	L	L	d	H	L	H	L	L	L	L	L	Q=d	L	L
	L	L	d	H	H	H	L	L	L	L	L	L	Q=d	L
Store (do nothing)	H	H	X	X	X	X	q0	q1	q2	q3	q4	q5	q6	q7
Addressable latch	H	L	d	L	L	L	Q=d	q1	q2	q3	q4	q5	q6	q7
	H	L	d	H	L	L	q0	Q=d	q2	q3	q4	q5	q6	q7
	H	L	d	L	H	L	q0	q1	Q=d	q3	q4	q5	q6	q7
	H	L	d	H	H	L	q0	q1	q2	Q=d	q4	q5	q6	q7
	H	L	d	L	L	H	q0	q1	q2	q3	Q=d	q5	q6	q7
	H	L	d	H	L	H	q0	q1	q2	q3	q4	Q=d	q6	q7
	H	L	d	L	H	H	q0	q1	q2	q3	q4	q5	Q=q	q7
	H	L	d	H	H	H	q0	q1	q2	q3	q4	q5	q6	Q=d

NOTES:

H = HIGH voltage level

L = LOW voltage level

X = don't care

d = HIGH or LOW data one set-up time prior to the LOW-to-HIGH LE transition

q = lower case letters indicate the state of the referenced output established during the last cycle established during the last cycle in which it was addressed or cleared

RECOMMENDED OPERATING CONDITIONS

SYMBOL	PARAMETER	CONDITIONS	MIN	TYP	MAX	UNIT
V _{CC}	DC supply voltage	See Note 1	1.0	3.3	3.6	V
V _I	Input voltage		0	–	V _{CC}	V
V _O	Output voltage		0	–	V _{CC}	V
T _{amb}	Operating ambient temperature range in free air	See DC and AC characteristics	–40 –40		+85 +125	°C
t _r , t _f	Input rise and fall times	V _{CC} = 1.0V to 2.0V V _{CC} = 2.0V to 2.7V V _{CC} = 2.7V to 3.6V	– – –	– – –	500 200 100	ns/V

NOTE:

1. The LV is guaranteed to function down to V_{CC} = 1.0V (input levels GND or V_{CC}); DC characteristics are guaranteed from V_{CC} = 1.2V to V_{CC} = 5.5V.

8-bit addressable latch

74LV259

ABSOLUTE MAXIMUM RATINGS^{1, 2}

In accordance with the Absolute Maximum Rating System (IEC 134).

Voltages are referenced to GND (ground = 0 V).

SYMBOL	PARAMETER	CONDITIONS	RATING	UNIT
V_{CC}	DC supply voltage		-0.5 to +4.6	V
$\pm I_{IK}$	DC input diode current	$V_I < -0.5$ or $V_I > V_{CC} + 0.5V$	20	mA
$\pm I_{OK}$	DC output diode current	$V_O < -0.5$ or $V_O > V_{CC} + 0.5V$	50	mA
$\pm I_O$	DC output source or sink current – standard outputs	$-0.5V < V_O < V_{CC} + 0.5V$	25	mA
$\pm I_{GND}$, $\pm I_{CC}$	DC V_{CC} or GND current for types with – standard outputs		50	mA
T_{stg}	Storage temperature range		-65 to +150	°C
P_{TOT}	Power dissipation per package – plastic DIL – plastic mini-pack (SO) – plastic shrink mini-pack (SSOP and TSSOP)	for temperature range: -40 to +125°C above +70°C derate linearly with 12 mW/K above +70°C derate linearly with 8 mW/K above +60°C derate linearly with 5.5 mW/K	750 500 400	mW

NOTES:

- Stresses beyond those listed may cause permanent damage to the device. These are stress ratings only and functional operation of the device at these or any other conditions beyond those indicated under “recommended operating conditions” is not implied. Exposure to absolute-maximum-rated conditions for extended periods may affect device reliability.
- The input and output voltage ratings may be exceeded if the input and output current ratings are observed.

DC ELECTRICAL CHARACTERISTICS

Over recommended operating conditions. Voltages are referenced to GND (ground = 0 V).

SYMBOL	PARAMETER	TEST CONDITIONS	LIMITS					UNIT
			-40°C to +85°C			-40°C to +125°C		
			MIN	TYP ¹	MAX	MIN	MAX	
V_{IH}	HIGH level Input voltage	$V_{CC} = 1.2 V$	0.9			0.9		V
		$V_{CC} = 2.0 V$	1.4			1.4		
		$V_{CC} = 2.7$ to $3.6 V$	2.0			2.0		
V_{IL}	LOW level Input voltage	$V_{CC} = 1.2 V$			0.3		0.3	V
		$V_{CC} = 2.0 V$			0.6		0.6	
		$V_{CC} = 2.7$ to $3.6 V$			0.8		0.8	
V_{OH}	HIGH level output voltage; all outputs	$V_{CC} = 1.2 V$; $V_I = V_{IH}$ or V_{IL} ; $-I_O = 100\mu A$		1.2				V
		$V_{CC} = 2.0 V$; $V_I = V_{IH}$ or V_{IL} ; $-I_O = 100\mu A$	1.8	2.0		1.8		
		$V_{CC} = 2.7 V$; $V_I = V_{IH}$ or V_{IL} ; $-I_O = 100\mu A$	2.5	2.7		2.5		
		$V_{CC} = 3.0 V$; $V_I = V_{IH}$ or V_{IL} ; $-I_O = 100\mu A$	2.8	3.0		2.8		
V_{OH}	HIGH level output voltage; STANDARD outputs	$V_{CC} = 3.0 V$; $V_I = V_{IH}$ or V_{IL} ; $-I_O = 6mA$	2.40	2.82		2.20		V
V_{OL}	LOW level output voltage; all outputs	$V_{CC} = 1.2 V$; $V_I = V_{IH}$ or V_{IL} ; $I_O = 100\mu A$		0				V
		$V_{CC} = 2.0 V$; $V_I = V_{IH}$ or V_{IL} ; $I_O = 100\mu A$		0	0.2		0.2	
		$V_{CC} = 2.7 V$; $V_I = V_{IH}$ or V_{IL} ; $I_O = 100\mu A$		0	0.2		0.2	
		$V_{CC} = 3.0 V$; $V_I = V_{IH}$ or V_{IL} ; $I_O = 100\mu A$		0	0.2		0.2	
V_{OL}	LOW level output voltage; STANDARD outputs	$V_{CC} = 3.0 V$; $V_I = V_{IH}$ or V_{IL} ; $I_O = 6mA$		0.25	0.40		0.50	V

8-bit addressable latch

74LV259

DC ELECTRICAL CHARACTERISTICS (Continued)

Over recommended operating conditions. Voltages are referenced to GND (ground = 0 V).

SYMBOL	PARAMETER	TEST CONDITIONS	LIMITS					UNIT
			-40°C to +85°C			-40°C to +125°C		
			MIN	TYP ¹	MAX	MIN	MAX	
I_I	Input leakage current	$V_{CC} = 3.6\text{ V}; V_I = V_{CC}$ or GND			1.0		1.0	μA
I_{CC}	Quiescent supply current; MSI	$V_{CC} = 3.6\text{ V}; V_I = V_{CC}$ or GND; $I_O = 0$			20.0		160	μA
ΔI_{CC}	Additional quiescent supply current per input	$V_{CC} = 2.7\text{ V to }3.6\text{ V}; V_I = V_{CC} - 0.6\text{ V}$			500		850	μA

NOTE:1. All typical values are measured at $T_{amb} = 25^\circ\text{C}$.**AC CHARACTERISTICS**GND = 0V; $t_r = t_f \leq 2.5\text{ ns}$; $C_L = 50\text{ pF}$; $R_L = 1\text{ k}\Omega$

SYMBOL	PARAMETER	WAVEFORM	CONDITION	LIMITS					UNIT
				-40 to +85 °C			-40 to +125 °C		
				$V_{CC}(\text{V})$	MIN	TYP ¹	MAX	MIN	
t_{PHL}/t_{PLH}	Propagation delay D to Q_n	Figure 2	1.2		105				ns
			2.0		36	49		61	
			2.7		26	36		45	
			3.0 to 3.6		20 ²	29		36	
t_{PHL}/t_{PLH}	Propagation delay A_n to Q_n	Figure 3	1.2		105				ns
			2.0		36	49		61	
			2.7		26	36		45	
			3.0 to 3.6		20 ²	29		36	
t_{PHL}/t_{PLH}	Propagation delay \overline{LE} to Q_n	Figure 1	1.2		100				ns
			2.0		34	48		60	
			2.7		25	35		44	
			3.0 to 3.6		19 ²	28		35	
t_{PHL}	Propagation delay \overline{MR} to Q_n	Figure 4	1.2		90				ns
			2.0		31	43		53	
			2.7		23	31		39	
			3.0 to 3.6		17 ²	25		31	
t_w	\overline{LE} pulse width HIGH or LOW	Figure 1	2.0	34	10		41		ns
			2.7	25	8		30		
			3.0 to 3.6	20	6 ²		24		
t_w	\overline{MR} pulse width LOW	Figure 4	2.0	34	10		41		ns
			2.7	25	8		30		
			3.0 to 3.6	20	6 ²		24		
t_{su}	Set-up time D, A_n to \overline{LE}	Figure 5 and 6	1.2		35				ns
			2.0	24	12		29		
			2.7	18	9		21		
			3.0 to 3.6	14	7 ²		17		
t_h	Hold time D to \overline{LE}	Figure 5	1.2		-30				ns
			2.0	5	-10		5		
			2.7	5	-8		5		
			3.0 to 3.6	5	-6 ²		5		

8-bit addressable latch

74LV259

AC CHARACTERISTICS (Continued)

GND = 0V; $t_r = t_f \leq 2.5\text{ns}$; $C_L = 50\text{pF}$; $R_L = 1\text{K}\Omega$

SYMBOL	PARAMETER	WAVEFORM	CONDITION	-40 to +85 °C			-40 to +125 °C		UNIT
			V _{CC} (V)	MIN	TYP ¹	MAX	MIN	MAX	
t _h	Hold time A _n to $\overline{\text{LE}}$	Figure 6	1.2		-20				ns
			2.0	5	-7		5		
			2.7	5	-5		5		
			3.0 to 3.6	5	-4 ²		5		

NOTES:

1. Unless otherwise stated, all typical values are measured at T_{amb} = 25°C
2. Typical values are measured at V_{CC} = 3.3 V.

AC WAVEFORMS

V_M = 1.5 V at V_{CC} ≥ 2.7 V and ≤ 3.6V;
 V_M = 0.5 × V_{CC} at V_{CC} < 2.7 V and ≥ 4.5 V.
 V_{OL} and V_{OH} are the typical output voltage drop that occur with the output load.

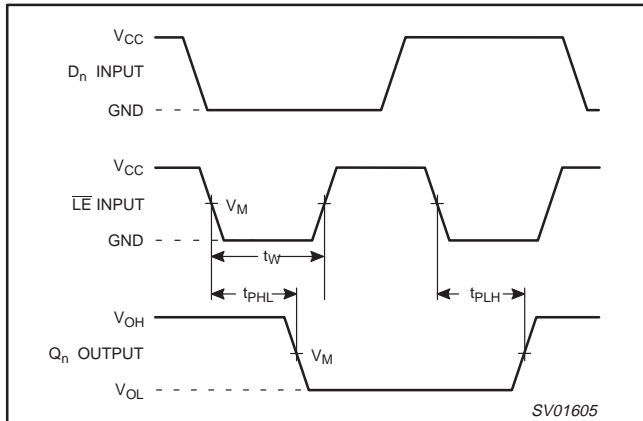

Figure 1. Enable input ($\overline{\text{LE}}$) to output (Q_n) propagation delays and the enable input pulse width.

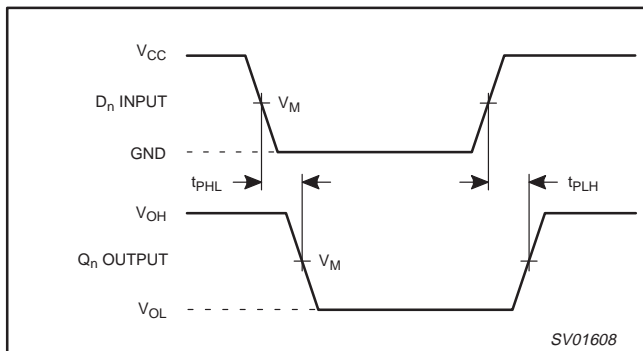

Figure 2. Data input (D) to output (Q_n) propagation delays.

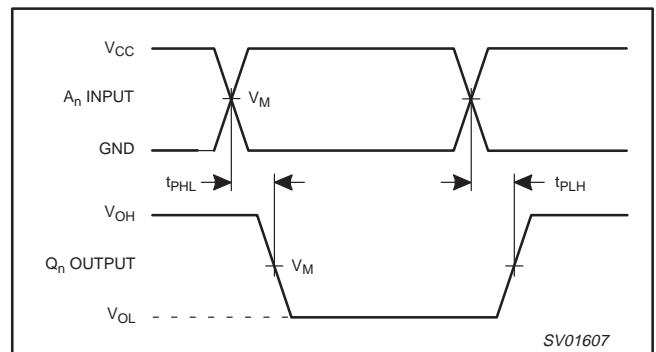

Figure 3. Address inputs (A_n) to output (Q_n) propagation delays.

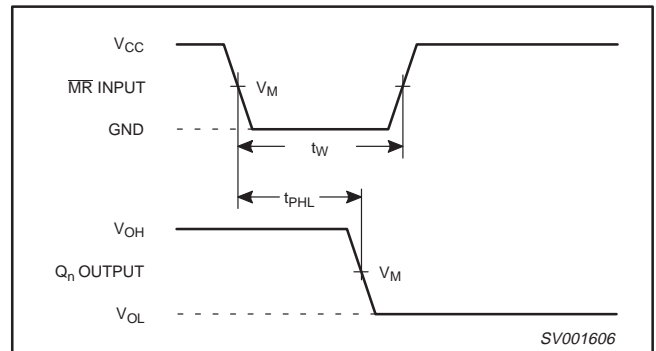

Figure 4. Conditional reset input ($\overline{\text{MR}}$) to output (Q_n) propagation delays.

8-bit addressable latch

74LV259

AC WAVEFORMS (Continued)

$V_M = 1.5\text{ V}$ at $V_{CC} \geq 2.7\text{ V}$ and $\leq 3.6\text{ V}$;
 $V_M = 0.5 \times V_{CC}$ at $V_{CC} < 2.7\text{ V}$ and $\geq 4.5\text{ V}$.
 V_{OL} and V_{OH} are the typical output voltage drop that occur with the output load.

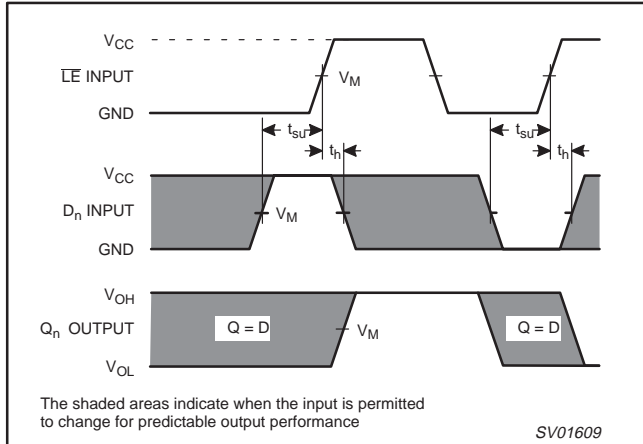

Figure 5. Data set-up and hold times for D input to LE input.

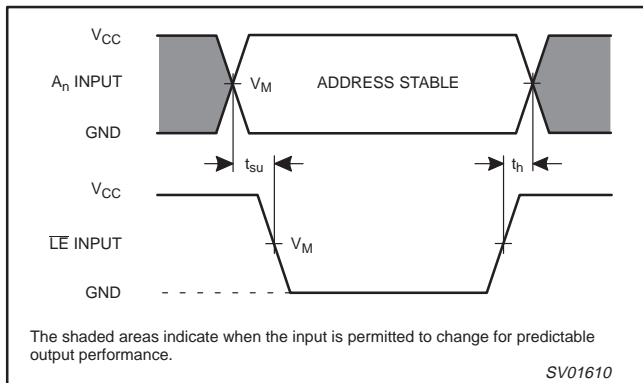

Figure 6. Address set-up and hold times for An inputs to LE input.

TEST CIRCUIT

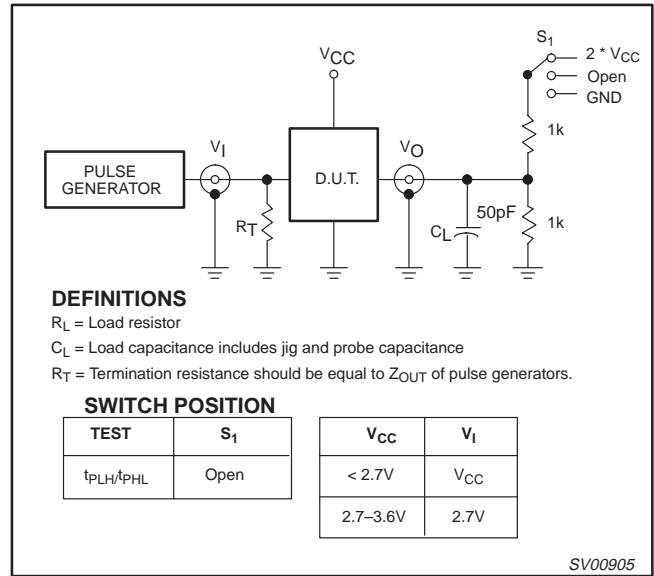

Figure 7. Load circuitry for switching times.

8-bit addressable latch

74LV259

DIP16: plastic dual in-line package; 16 leads (300 mil)

SOT38-4

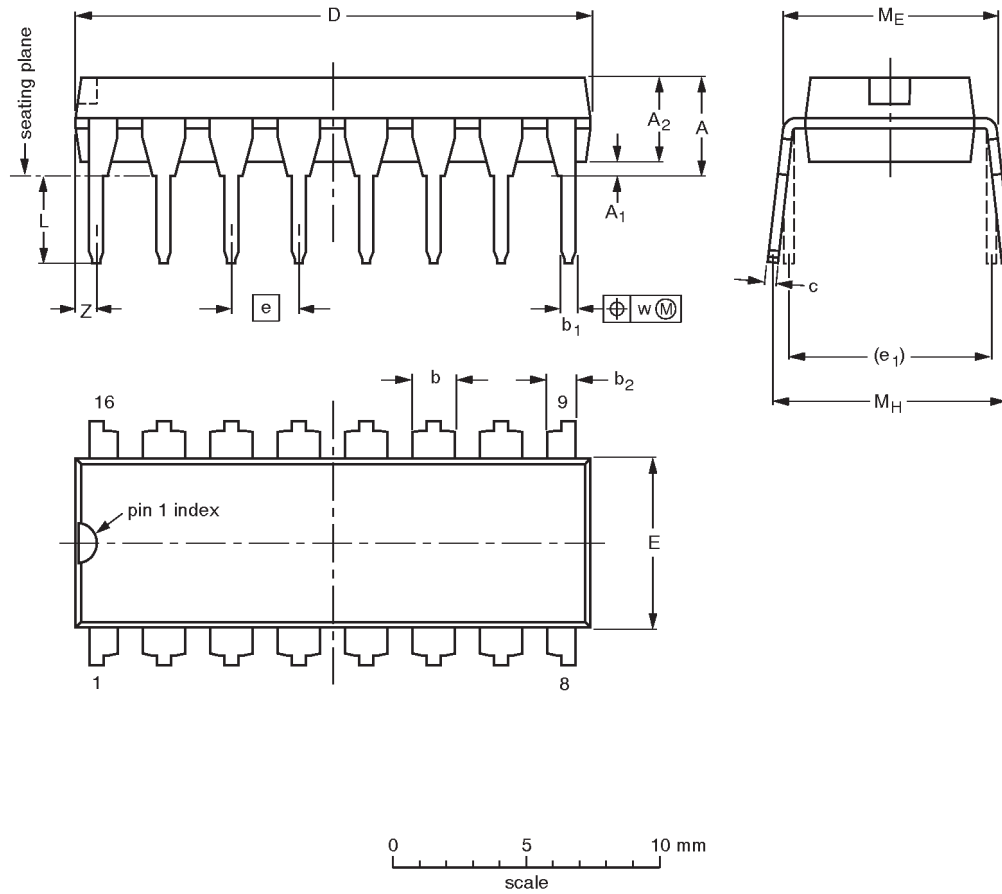

DIMENSIONS (inch dimensions are derived from the original mm dimensions)

UNIT	A max.	A ₁ min.	A ₂ max.	b	b ₁	b ₂	c	D ⁽¹⁾	E ⁽¹⁾	e	e ₁	L	M _E	M _H	w	Z ⁽¹⁾ max.
mm	4.2	0.51	3.2	1.73 1.30	0.53 0.38	1.25 0.85	0.36 0.23	19.50 18.55	6.48 6.20	2.54	7.62	3.60 3.05	8.25 7.80	10.0 8.3	0.254	0.76
inches	0.17	0.020	0.13	0.068 0.051	0.021 0.015	0.049 0.033	0.014 0.009	0.77 0.73	0.26 0.24	0.10	0.30	0.14 0.12	0.32 0.31	0.39 0.33	0.01	0.030

Note

1. Plastic or metal protrusions of 0.25 mm maximum per side are not included.

OUTLINE VERSION	REFERENCES				EUROPEAN PROJECTION	ISSUE DATE
	IEC	JEDEC	EIAJ			
SOT38-4						-92-11-17 95-01-14

8-bit addressable latch

74LV259

SO16: plastic small outline package; 16 leads; body width 3.9 mm

SOT109-1

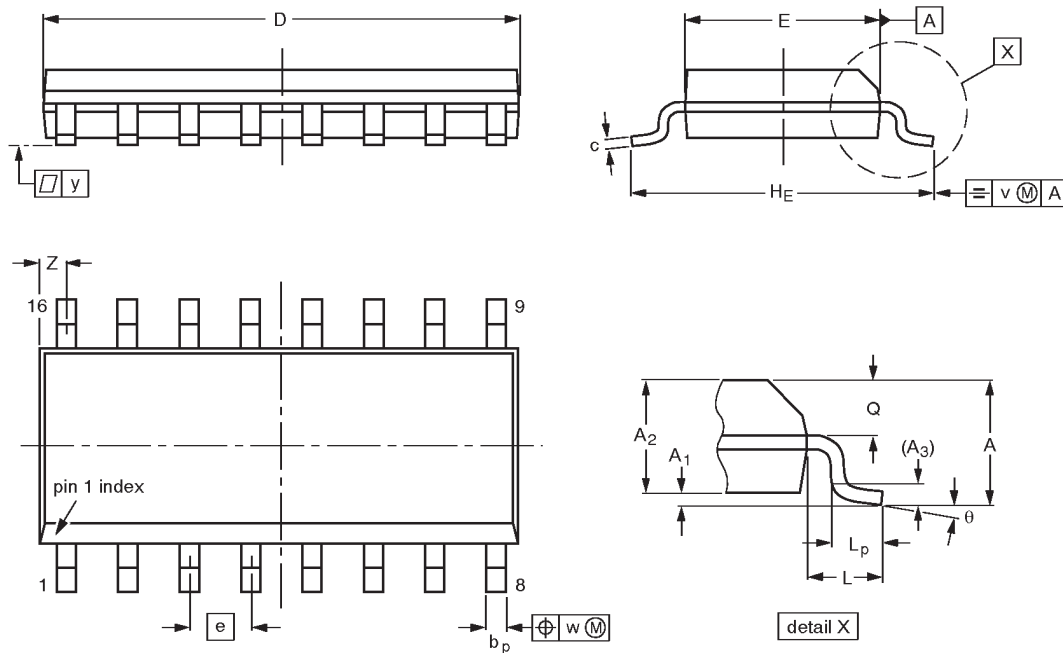

DIMENSIONS (inch dimensions are derived from the original mm dimensions)

UNIT	A max.	A ₁	A ₂	A ₃	b _p	c	D ⁽¹⁾	E ⁽¹⁾	e	H _E	L	L _p	Q	v	w	y	z ⁽¹⁾	θ
mm	1.75	0.25 0.10	1.45 1.25	0.25	0.49 0.36	0.25 0.19	10.0 9.8	4.0 3.8	1.27	6.2 5.8	1.05	1.0 0.4	0.7 0.6	0.25	0.25	0.1	0.7 0.3	8° 0°
inches	0.069	0.0098 0.0039	0.057 0.049	0.01	0.019 0.014	0.0098 0.0075	0.39 0.38	0.16 0.15	0.050	0.24 0.23	0.041	0.039 0.016	0.028 0.020	0.01	0.01	0.004	0.028 0.012	

Note

1. Plastic or metal protrusions of 0.15 mm maximum per side are not included.

OUTLINE VERSION	REFERENCES				EUROPEAN PROJECTION	ISSUE DATE
	IEC	JEDEC	EIAJ			
SOT109-1	076E07S	MS-012AC				91-08-13 95-01-23

8-bit addressable latch

74LV259

SSOP16: plastic shrink small outline package; 16 leads; body width 5.3 mm

SOT338-1

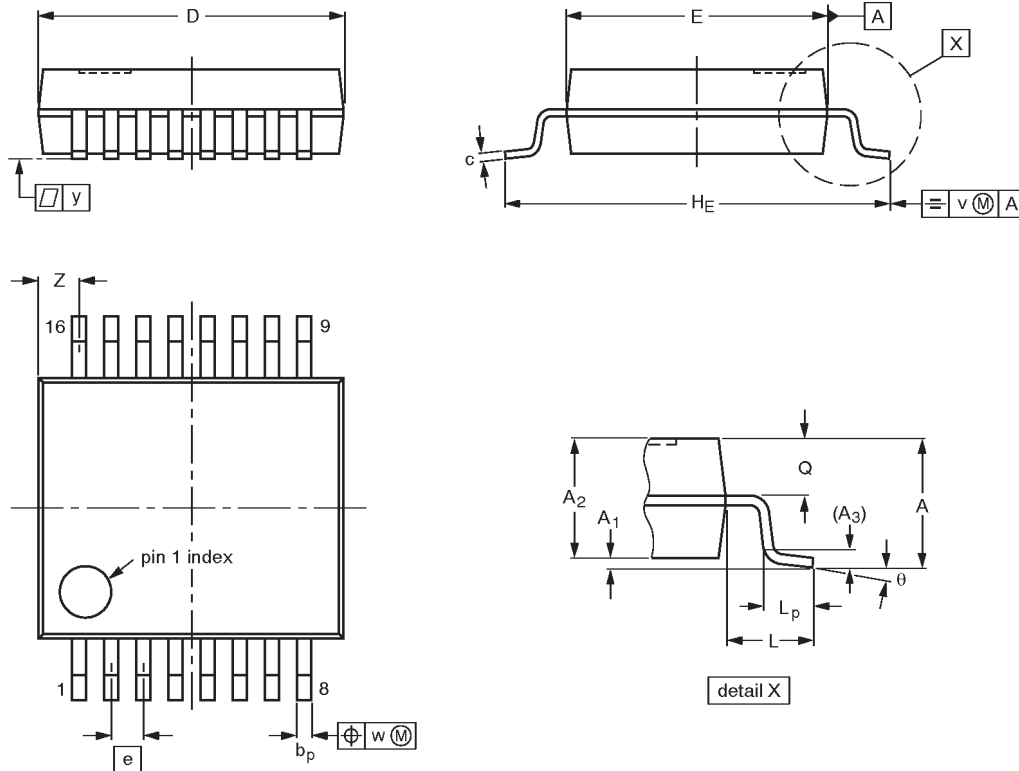

DIMENSIONS (mm are the original dimensions)

UNIT	A max.	A ₁	A ₂	A ₃	b _p	c	D ⁽¹⁾	E ⁽¹⁾	e	H _E	L	L _p	Q	v	w	y	Z ⁽¹⁾	θ
mm	2.0	0.21 0.05	1.80 1.65	0.25	0.38 0.25	0.20 0.09	6.4 6.0	5.4 5.2	0.65	7.9 7.6	1.25	1.03 0.63	0.9 0.7	0.2	0.13	0.1	1.00 0.55	8° 0°

Note

1. Plastic or metal protrusions of 0.25 mm maximum per side are not included.

OUTLINE VERSION	REFERENCES				EUROPEAN PROJECTION	ISSUE DATE
	IEC	JEDEC	EIAJ			
SOT338-1		MO-150AC				94-01-14- 95-02-04

8-bit addressable latch

74LV259

TSSOP16: plastic thin shrink small outline package; 16 leads; body width 4.4 mm

SOT403-1

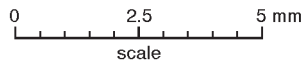
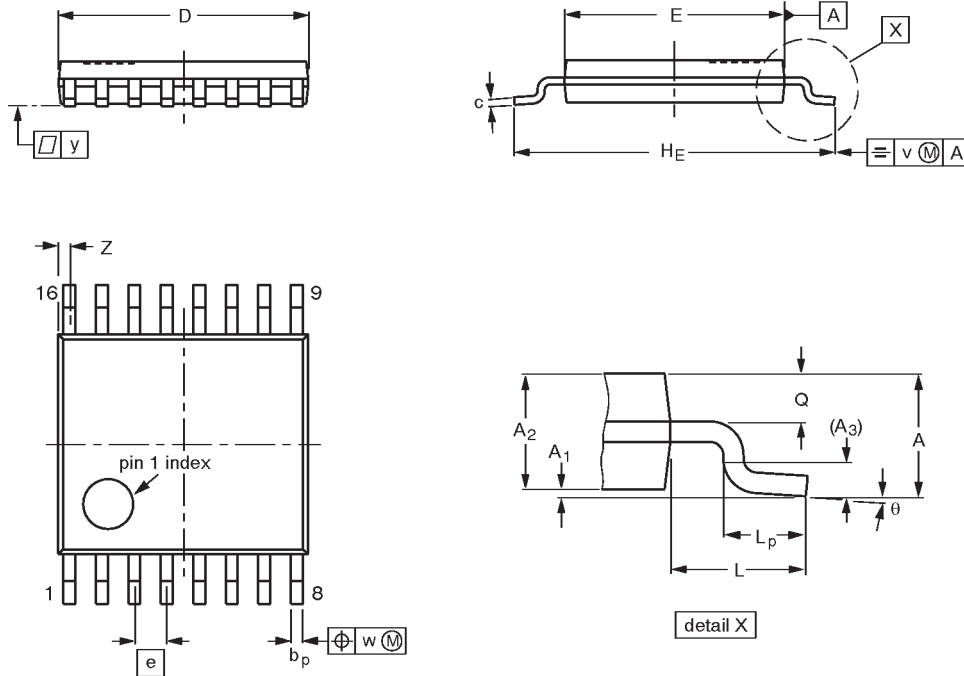

DIMENSIONS (mm are the original dimensions)

UNIT	A max.	A ₁	A ₂	A ₃	b _p	c	D ⁽¹⁾	E ⁽²⁾	e	H _E	L	L _p	Q	v	w	y	Z ⁽¹⁾	θ
mm	1.10	0.15 0.05	0.95 0.80	0.25	0.30 0.19	0.2 0.1	5.1 4.9	4.5 4.3	0.65	6.6 6.2	1.0	0.75 0.50	0.4 0.3	0.2	0.13	0.1	0.40 0.06	8° 0°

Notes

1. Plastic or metal protrusions of 0.15 mm maximum per side are not included.
2. Plastic interlead protrusions of 0.25 mm maximum per side are not included.

OUTLINE VERSION	REFERENCES				EUROPEAN PROJECTION	ISSUE DATE
	IEC	JEDEC	EIAJ			
SOT403-1		MO-153				94-07-12 95-04-04

8-bit addressable latch

74LV259

NOTES

8-bit addressable latch

74LV259

DEFINITIONS

Data Sheet Identification	Product Status	Definition
<i>Objective Specification</i>	Formative or in Design	This data sheet contains the design target or goal specifications for product development. Specifications may change in any manner without notice.
<i>Preliminary Specification</i>	Preproduction Product	This data sheet contains preliminary data, and supplementary data will be published at a later date. Philips Semiconductors reserves the right to make changes at any time without notice in order to improve design and supply the best possible product.
<i>Product Specification</i>	Full Production	This data sheet contains Final Specifications. Philips Semiconductors reserves the right to make changes at any time without notice, in order to improve design and supply the best possible product.

Philips Semiconductors and Philips Electronics North America Corporation reserve the right to make changes, without notice, in the products, including circuits, standard cells, and/or software, described or contained herein in order to improve design and/or performance. Philips Semiconductors assumes no responsibility or liability for the use of any of these products, conveys no license or title under any patent, copyright, or mask work right to these products, and makes no representations or warranties that these products are free from patent, copyright, or mask work right infringement, unless otherwise specified. Applications that are described herein for any of these products are for illustrative purposes only. Philips Semiconductors makes no representation or warranty that such applications will be suitable for the specified use without further testing or modification.

LIFE SUPPORT APPLICATIONS

Philips Semiconductors and Philips Electronics North America Corporation Products are not designed for use in life support appliances, devices, or systems where malfunction of a Philips Semiconductors and Philips Electronics North America Corporation Product can reasonably be expected to result in a personal injury. Philips Semiconductors and Philips Electronics North America Corporation customers using or selling Philips Semiconductors and Philips Electronics North America Corporation Products for use in such applications do so at their own risk and agree to fully indemnify Philips Semiconductors and Philips Electronics North America Corporation for any damages resulting from such improper use or sale.

Philips Semiconductors
811 East Arques Avenue
P.O. Box 3409
Sunnyvale, California 94088-3409
Telephone 800-234-7381

© Copyright Philips Electronics North America Corporation 1998
 All rights reserved. Printed in U.S.A.

print code

Date of release: 05-96

Document order number:

9397-750-04442

Let's make things better.

Copyright © Each Manufacturing Company.

All Datasheets cannot be modified without permission.

This datasheet has been download from :

www.AllDataSheet.com

100% Free DataSheet Search Site.

Free Download.

No Register.

Fast Search System.

www.AllDataSheet.com