



**Microsemi Corp.**  
The diode experts

SCOTTSDALE, AZ  
For more information call:  
(602) 941-6300

**1N4099 thru  
1N4135  
and  
1N4614 thru  
1N4627  
DO-35**

**FEATURES**

- ZENER VOLTAGE 1.8 TO 100 V
- ALL HAVE JAN, JANTX AND JANTXV-1 QUALIFICATIONS TO MIL-S-19500/435
- LOW NOISE
- LOW REVERSE LEAKAGE

**MAXIMUM RATINGS**

Junction and Storage Temperatures: -65°C to +200°C  
DC Power Dissipation: 500mW  
Power Derating: 4.0 mW/C\* above 50°C in DO-35  
Forward Voltage @ 200 mA: 1.1 Volts 1N4099-1N4135  
@ 100 mA: 1.0 Volts 1N4614-1N4627

**SILICON  
500 mW  
LOW NOISE  
ZENER DIODES**

\* **ELECTRICAL CHARACTERISTICS @ 25°C**

JEDEC TYPE NO.	NOMINAL ZENER VOLTAGE $V_Z @ I_Z T$ (Note 1)	ZENER TEST CURRENT $I_Z T$	MAXIMUM ZENER IMPEDANCE $Z_{ZT}$ (Note 2)	MAXIMUM REVERSE CURRENT $I_Z @ V_R$		MAXIMUM NOISE DENSITY $N_D @ I_Z T$	MAXIMUM ZENER CURRENT $I_{ZM}$ (Note 3)	MAXIMUM TEMP. COEFF. OF ZENER VOLTAGE $\Delta V_Z$
	VOLTS	$\mu A$	OHMS	$\mu A$	VOLTS	$\mu V/Hz$	mA	%/°C
1N4614	1.8	250	1200	7.5	1	1	120	-0.075
1N4615	2.0	250	1250	5.0	1	1	110	-0.075
1N4616	2.2	250	1300	4.0	1	1	100	-0.075
1N4617	2.4	250	1400	2.0	1	1	95	-0.075
1N4618	2.7	250	1500	1.0	1	1	90	-0.075
1N4619	3.0	250	1600	0.8	1	1	87	-0.075
1N4620	3.3	250	1650	7.5	1.5	1	85	-0.075
1N4621	3.6	250	1700	7.5	2	1	83	-0.065
1N4622	3.9	250	1650	5.0	2	1	80	-0.060
1N4623	4.3	250	1600	4.0	2	1	77	-0.050
1N4624	4.7	250	1550	10.0	3	1	75	-0.050 +0.020
1N4625	5.1	250	1500	10.0	3	2	70	-0.045 +0.030
1N4626	5.6	250	1400	10.0	4	4	65	-0.020 +0.040
1N4627	6.2	250	1200	10.0	5	5	61	-0.010 +0.050
1N4099	6.8	250	200	10.0	5.17	40	56	0.060
1N4100	7.5	250	200	10.0	5.70	40	51	0.065
1N4101	8.2	250	200	1.0	6.24	40	46	0.070
1N4102	8.7	250	200	1.0	6.61	40	44	0.075
1N4103	9.1	250	200	1.0	6.92	40	42	0.080
1N4104	10	250	200	1.0	7.60	40	38	0.080
1N4105	11	250	200	.05	8.44	40	35	0.080
1N4106	12	250	200	.05	9.12	40	32	0.080
1N4107	13	250	200	.05	9.87	40	29	0.080
1N4108	14	250	200	.05	10.65	40	27	0.085
1N4109	15	250	100	.05	11.40	40	25	0.085
1N4110	16	250	100	.05	12.15	40	24	0.085
1N4111	17	250	100	.05	12.92	40	22	0.090
1N4112	18	250	100	.05	13.67	40	21	0.090
1N4113	19	250	150	.05	14.44	40	20	0.090
1N4114	20	250	150	.01	15.20	40	19	0.090
1N4115	22	250	150	.01	16.72	40	17	0.090
1N4116	24	250	150	.01	18.25	40	16	0.090
1N4117	25	250	150	.01	19.00	40	15	0.090
1N4118	27	250	150	.01	20.45	40	14	0.090
1N4119	28	250	200	.01	21.28	40	14	0.095
1N4120	30	250	200	.01	22.80	40	13	0.095
1N4121	33	250	200	.01	25.08	40	12	0.095
1N4122	36	250	200	.01	27.38	40	11	0.095
1N4123	39	250	200	.01	29.65	40	9.8	0.095
1N4124	43	250	250	.01	32.65	40	8.9	0.095
1N4125	47	250	250	.01	35.75	40	8.1	0.095
1N4126	51	250	300	.01	38.76	40	7.5	0.100
1N4127	56	250	300	.01	42.60	40	6.7	0.100
1N4128	60	250	400	.01	45.60	40	6.4	0.100
1N4129	62	250	500	.01	47.30	40	6.1	0.100
1N4130	68	250	700	.01	51.68	40	5.6	0.100
1N4131	75	250	700	.01	57.00	40	5.1	0.100
1N4132	82	250	800	.01	62.32	40	4.6	0.100
1N4133	87	250	1000	.01	66.12	40	4.4	0.100
1N4134	91	250	1200	.01	69.16	40	4.2	0.100
1N4135	100	250	1500	.01	76.00	40	3.8	0.100

\*JEDC Registered Data.

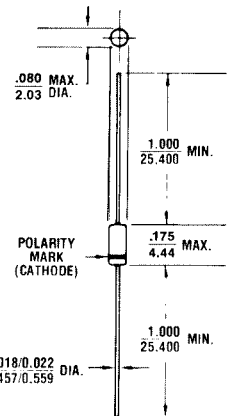

FIGURE 1

All dimensions in INCH  
m.m.

**MECHANICAL CHARACTERISTICS**

CASE: Hermetically sealed glass case. DO-35.

FINISH: All external surfaces are corrosion resistant and leads solderable.

THERMAL RESISTANCE: 200°C/W (Typical) junction to lead at 0.375-inches from body in DO-35. Metallurgically bonded DO-35's exhibit less than 100°C/W at zero distance from body.

POLARITY: Diode to be operated with the banded end positive with respect to the opposite end.

WEIGHT: 0.2 grams.

MOUNTING POSITION: Any.

# 1N4099 thru 1N4135, 1N4614 thru 1N4627 DO-35

Noise density, ( $N_D$ ) is specified in microvolts-rms per square-root-hertz. Actual measurement is performed using a 1 KHz to 3 KHz frequency bandpass filter at a constant Zener test current ( $I_{ZT}$ ) at 25°C ambient temperature.  $N_D$  is calculated from the formula.

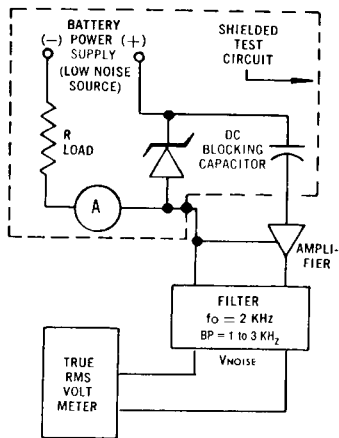

**FIGURE 2** NOISE DENSITY MEASUREMENT CIRCUIT

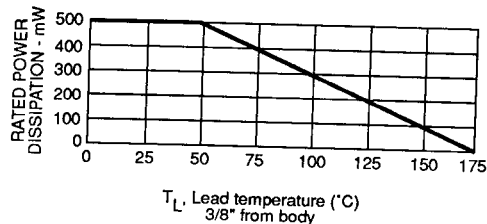

**FIGURE 3** POWER DERATING CURVE

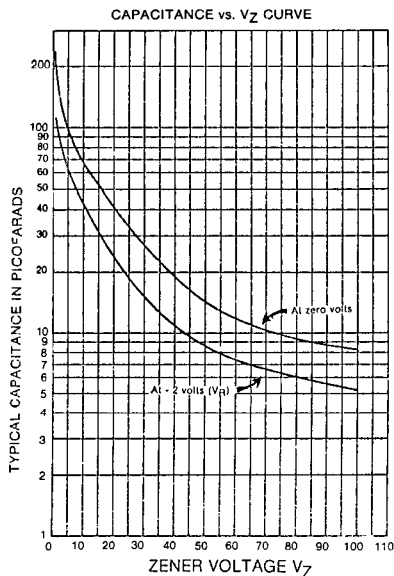

**FIGURE 4**  
CAPACITANCE VS. ZENER VOLTAGE  
(TYPICAL)

**NOTE 1** The JEDEC type numbers shown above have a standard tolerance of  $\pm 5\%$  on the nominal Zener voltage. Also available in 2% and 1% tolerance, suffix C and D respectively.  $V_Z$  is measured with the diode in thermal equilibrium in 25°C still air.

**NOTE 2** Zener impedance is derived by superimposing on  $I_{ZT}$ , a 60 Hz rms a.c. current equal to 10% of  $I_{ZT}$  (25 $\mu$ A a.c.).

**NOTE 3** Based upon 400 mW maximum power dissipation at 75°C lead temperature, allowance has been made for the higher voltage associated with operation at higher currents.

This datasheet has been download from :

[www.AllDataSheet.com](http://www.AllDataSheet.com)

100% Free DataSheet Search Site.

Free Download.

No Register.

Fast Search System.

[www.AllDataSheet.com](http://www.AllDataSheet.com)