

19-0016; Rev 1; 1/95

MAXIM

140MHz, 2-Channel Video Multiplexer/Amplifier

MAX442

General Description

The MAX442 combines a 140MHz video amplifier with a high-speed, 2-channel multiplexer in an 8-pin package. With its 36ns switching time and low differential gain (0.07%) and phase (0.09°) errors, it is ideal for broadcast-quality video applications. The device is designed to drive both 50Ω and 75Ω cables, and can directly drive a 75Ω load to ±3V.

The MAX442 video amplifier is compensated for unity-gain stability, and features a 140MHz bandwidth and a 250V/μs slew rate. The multiplexer's low input capacitance (4pF with the channel on or off) maximizes high-speed performance, and a ground pin separating the two input channels minimizes crosstalk and simplifies board layout.

The MAX442 operates from ±5V supplies and typically consumes 300mW. For applications that require more input channels, see the data sheets for the MAX440 8-channel mux/amp and the MAX441 4-channel mux/amp.

Applications

- Broadcast-Quality Video-Signal Multiplexing
- Coaxial-Cable Drivers
- Video Editing
- Video Security Systems
- Medical Imaging
- High-Speed Signal Processing

Pin Configuration

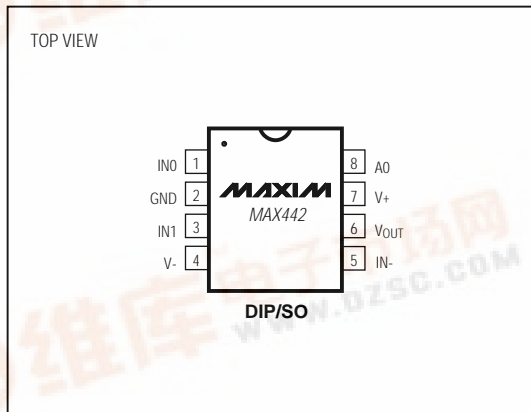

Features

- ◆ 140MHz Unity-Gain Bandwidth
- ◆ 250V/μs Slew Rate
- ◆ 0.07%/0.09° Differential Gain/Phase Error
- ◆ 36ns Channel Switch Time
- ◆ No External Compensation Components
- ◆ 8-Pin DIP and SO Packages
- ◆ Directly Drives 50Ω and 75Ω Cables

Ordering Information

PART	TEMP. RANGE	PIN-PACKAGE
MAX442CPA	0°C to +70°C	8 Plastic DIP
MAX442CSA	0°C to +70°C	8 SO
MAX442C/D	0°C to +70°C	Dice*
MAX442EPA	-40°C to +85°C	8 Plastic DIP
MAX442ESA	-40°C to +85°C	8 SO

*Dice are specified at $T_A = +25^\circ\text{C}$, DC parameters only.

Typical Operating Circuit

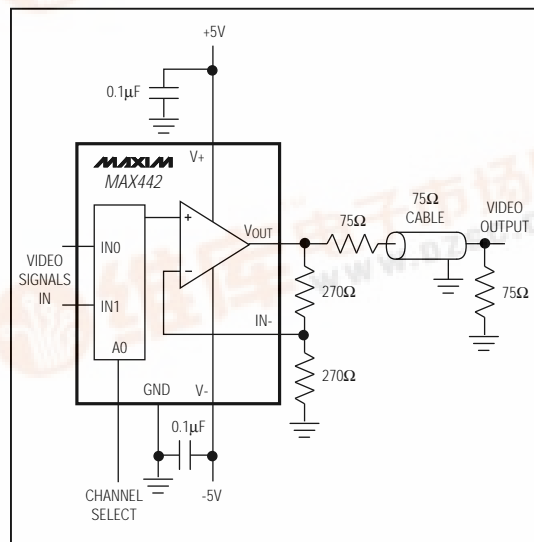

140MHz, 2-Channel Video Multiplexer/Amplifier

ABSOLUTE MAXIMUM RATINGS

Supply Voltage (V+ to V-)	12V
Analog Input Voltage	(V+ + 0.3V) to (V- - 0.3V)
Digital Input Voltage	-0.3V to (V+ + 0.3V)
Short-Circuit Current Duration	1 minute
Input Current to Any Pin, Power On or Off	±50mA
Continuous Power Dissipation (T _A = +70°C)	
Plastic DIP (derate 9.09mW/°C above +70°C)	727mW
SO (derate 5.88mW/°C above +70°C)	471mW

Operating Temperature Ranges

MAX442C_A	0°C to +70°C
MAX442E_A	-40°C to +85°C
Storage Temperature Range	-65°C to +150°C
Lead Temperature (soldering, 10sec)	+300°C

Stresses beyond those listed under "Absolute Maximum Ratings" may cause permanent damage to the device. These are stress ratings only, and functional operation of the device at these or any other conditions beyond those indicated in the operational sections of the specifications is not implied. Exposure to absolute maximum rating conditions for extended periods may affect device reliability.

ELECTRICAL CHARACTERISTICS

(V+ = 5V, V- = -5V, R_L = 150Ω, T_A = T_{MIN} to T_{MAX}, unless otherwise noted.)

PARAMETER	SYMBOL	CONDITIONS	MIN	TYP	MAX	UNITS
DC PERFORMANCE						
Input Voltage Range	V _{IN}		-2		2	V
Input Offset Voltage (All Channels)	V _{OS}	T _A = +25°C		±1.5	±7.0	mV
		MAX442C			±10	
		MAX442E			±12	
Offset Matching (V _{OS0} -V _{OS1})		T _A = +25°C		±1	±2.5	mV
		T _A = T _{MIN} to T _{MAX}			±5.0	
Input Bias Current (Channel On)	I _B	V _{IN} = 0V	T _A = +25°C	±0.6	±2	μA
			T _A = T _{MIN} to T _{MAX}		±5	
Input Leakage Current (Channel Off)	I _{LKG}	V _{IN} = 0V	T _A = +25°C	±0.5	±50	nA
			T _A = T _{MIN} to T _{MAX}		±1	μA
Input Resistance (Channel On) (Note 1)	R _{IN}	-2V ≤ V _{CM} ≤ 2V	T _A = +25°C	0.5	2.0	MΩ
			T _A = T _{MIN} to T _{MAX}	0.2		
Input Capacitance	C _{IN}	Channel on or off		4		pF
DC Output Resistance	R _{OUT}		A _V = 0dB		25	mΩ
			A _V = 6dB		50	
Open-Loop Voltage Gain	A _{VOL}	R _L = 75Ω, -2V ≤ V _{OUT} ≤ +2V	T _A = +25°C	50	60	dB
			T _A = T _{MIN} to T _{MAX}	46		
Common-Mode Rejection Ratio	CMRR	-2V ≤ V _{IN} ≤ +2V	T _A = +25°C	46	50	dB
			T _A = T _{MIN} to T _{MAX}	46		
Power-Supply Rejection Ratio	PSRR	±4.75V to ±5.25V	T _A = +25°C	54	80	dB
			T _A = T _{MIN} to T _{MAX}	54		
Output Voltage Swing	V _{OUT}	R _L = 75Ω	T _A = +25°C	±2.5	±3.0	V
			T _A = T _{MIN} to T _{MAX}	±2.0		

140MHz, 2-Channel Video Multiplexer/Amplifier

MAX442

ELECTRICAL CHARACTERISTICS (continued)

(V₊ = 5V, V₋ = -5V, R_L = 150Ω, T_A = T_{MIN} to T_{MAX}, unless otherwise noted.)

PARAMETER	SYMBOL	CONDITIONS	MIN	TYP	MAX	UNITS	
DYNAMIC PERFORMANCE							
-3dB Bandwidth	BW	A _V = 0dB, R _L = 100Ω		140		MHz	
Slew Rate	SR1			250		V/μs	
Differential Phase Error	DP	Figure 1		0.09		degrees	
Differential Gain Error	DG	Figure 1		0.07		%	
Settling Time	t _s	To 0.1% of final value, A _V = 0dB, R _L = 150Ω, 2V step input		50		ns	
Crosstalk	XTALK	f = 10MHz, R _S = 75Ω, A _V = 0dB, Figure 6		76		dB	
Input Noise-Voltage Density	e _n	f = 10kHz		12		nV/√Hz	
POWER REQUIREMENTS							
Operating Supply-Voltage Range	V _S		±4.75		±5.25	V	
Positive Supply Current	I _{CC}	V _{IN} = 0V	T _A = +25°C	25	30	35	mA
			MAX442C	22		38	
			MAX442E	19		41	
Negative Supply Current	I _{EE}	V _{IN} = 0V	T _A = +25°C	23	28	35	mA
			MAX442C	20		38	
			MAX442E	17		41	
SWITCHING CHARACTERISTICS							
Logic Low Voltage	V _{IL}				0.8	V	
Logic High Voltage	V _{IH}		2.4			V	
Address Propagation Delay	t _{APD}	Figure 7		24		ns	
Channel Switching Time	t _{sw}	Figure 7 (Note 2)		36		ns	

Note 1: Incremental resistance for a common-mode voltage between ±2V.

Note 2: Channel Switching Time specified between two grounded input channels; does not include signal rise/fall times for switching between channels with different input voltages.

Typical Operating Characteristics

(T_A = +25°C, unless otherwise noted.)

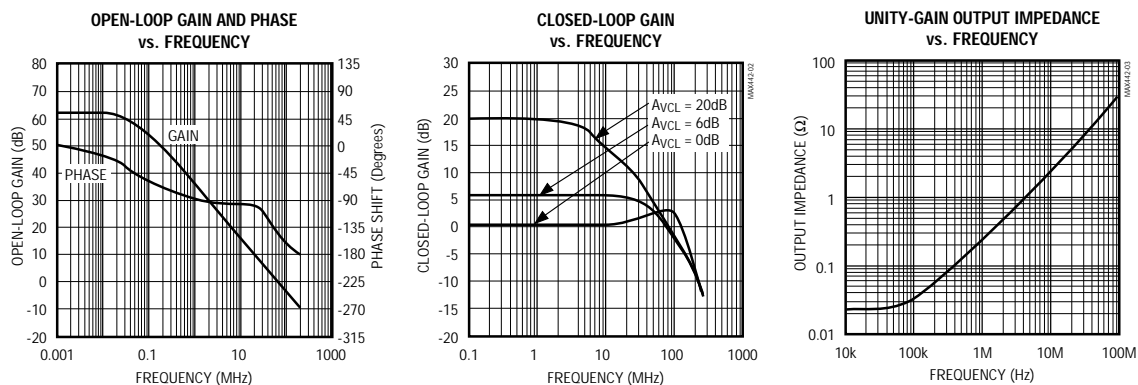

140MHz, 2-Channel Video Multiplexer/Amplifier

Typical Operating Characteristics (continued)

($T_A = +25^\circ\text{C}$, unless otherwise noted.)

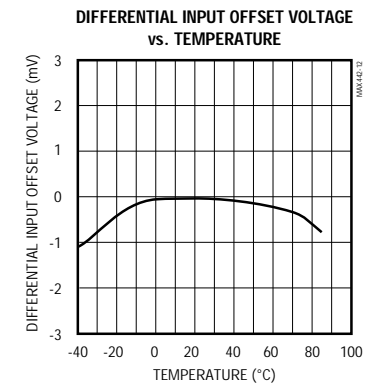
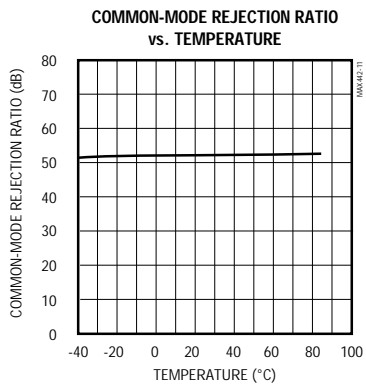
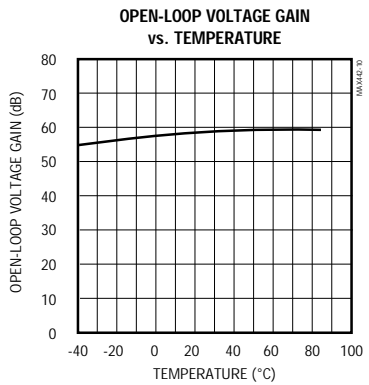
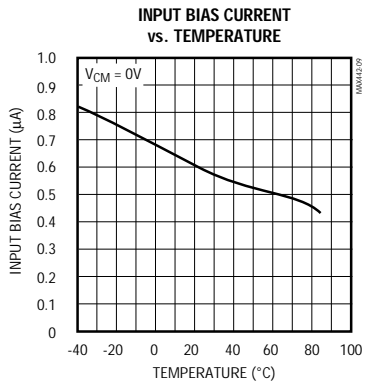
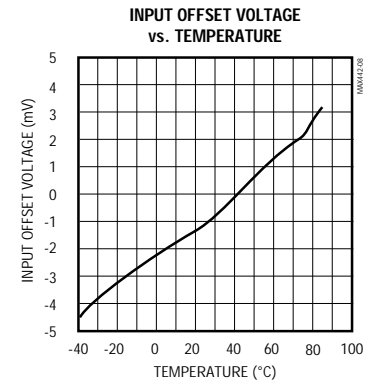
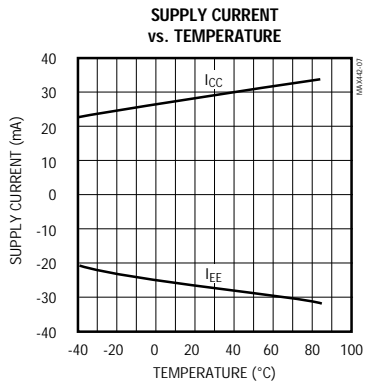
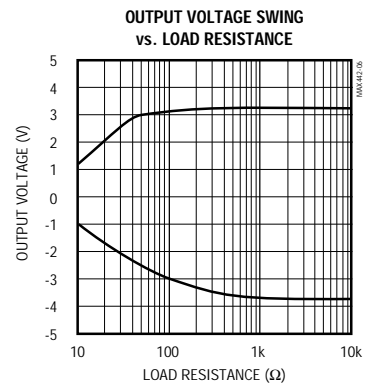
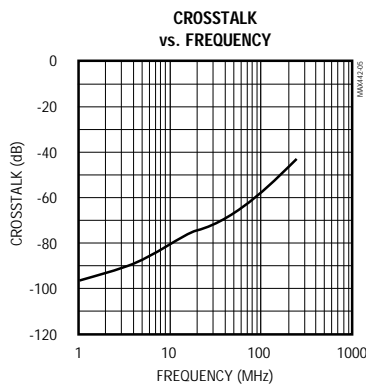
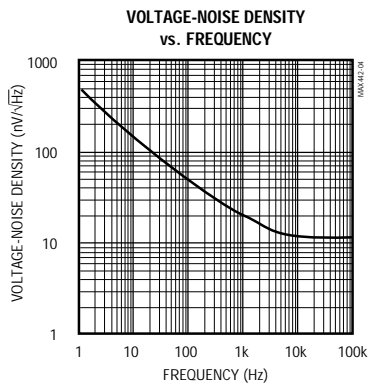

140MHz, 2-Channel Video Multiplexer/Amplifier

MAX442

Pin Description

PIN	NAME	FUNCTION
1	IN0	Analog Input, channel 0
2	GND	Ground
3	IN1	Analog Input, channel 1
4	V-	Negative Power Supply, -5V
5	IN-	Amplifier Inverting Input
6	VOUT	Amplifier Output
7	V+	Positive Power Supply, +5V
8	A0	Channel Address Input: A0 = logic 0 selects channel 0, A0 = logic 1 selects channel 1

Applications Information

The MAX442's bipolar construction results in a typical channel input capacitance of only 4pF, whether the channel is on or off. As with all ICs, the mux's input capacitance forms a single-pole RC lowpass filter with the signal source's output impedance. This filter can limit the system's signal bandwidth if the RC product becomes too large. However, the MAX442's low channel input capacitance allows full AC performance of the amplifier, even with source impedances as great as 250Ω—a significant improvement over common mux or switch alternatives.

Feedback resistors should be limited to no more than 500Ω to ensure that the RC time constant formed by the resistors, the circuit board's capacitance, and the capacitance of the amplifier input pins does not limit the system's high-speed performance.

Power-Supply Bypassing and Board Layout

Realizing the full AC performance of high-speed amplifiers requires careful attention to power-supply bypassing and board layout. Use a low-impedance ground plane with the MAX442. With multilayer boards, the ground plane should be located on the PC board's component side to minimize impedance between the components and the ground plane. For single-layer boards, components should be mounted on the board's copper side and the ground plane should include the entire portion of the board that is not dedicated to a specific signal trace.

To prevent oscillation and unwanted signal coupling, minimize trace area at the circuit's critical high-impedance nodes, especially the amplifier summing junction (the amplifier's inverting input). Surround these critical nodes with a ground trace, and include ground traces between all signal traces to minimize parasitic coupling that can degrade crosstalk and/or amplifier stability. Keep signal paths as short as possible to minimize inductance, and keep all input channel traces at equal lengths to maintain the phase relationship between the input channels.

Bypass all power-supply pins directly to the ground plane with 0.1μF ceramic capacitors, placed as close to the supply pins as possible. For high-current loads, it may be necessary to include 1μF tantalum or aluminum-electrolytic capacitors in parallel with the 0.1μF ceramic bypass capacitors. Keep capacitor lead lengths as short as possible to minimize series inductance; surface-mount (chip) capacitors are ideal for this application.

Differential Gain and Phase Errors

In color video applications, lowest differential gain and phase errors are critical for an IC, because they cause changes in contrast and color of the displayed picture. Typically, the MAX442's multiplexer/amplifier combination has a differential gain and phase error of only 0.07% and 0.09°, respectively. This low differential gain and phase error makes the MAX442 ideal for use in broadcast-quality color video systems.

Coaxial-Cable Drivers

High-speed performance and excellent output current capability make the MAX442 ideal for driving 50Ω or 75Ω coaxial cables. The MAX442 will drive 50Ω and 75Ω coaxial cables to ±3V.

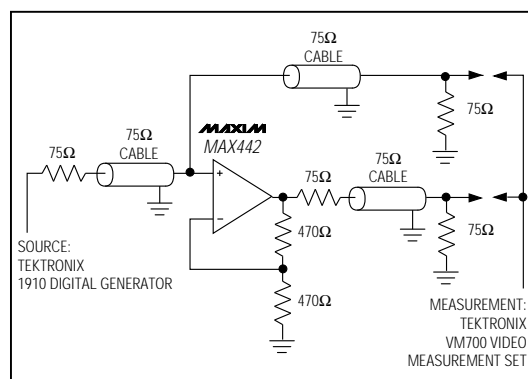

Figure 1. Differential Gain and Phase Error Test Circuit

140MHz, 2-Channel Video Multiplexer/Amplifier

The *Typical Operating Circuit* shows the MAX442 driving a back-terminated 75Ω video cable. The back-termination resistor (at the MAX442 output) is included to match the impedance of the cable's driven end to the characteristic impedance of the cable itself. This, plus the load-termination resistor, eliminates signal reflections from the cable's ends. The back-termination resistor forms a voltage divider with the load impedance, which attenuates the signal at the cable output by one-half. The amplifier is operated with a 2V/V closed-loop gain to provide unity gain at the cable's video output.

Capacitive-Load Driving

Driving large capacitive loads increases the likelihood of oscillation in most amplifier circuits. This is especially true for circuits with high loop gains, like voltage fol-

lowers. The amplifier's output impedance and the capacitive load form an RC filter that adds a pole to the loop response. If the pole frequency is low enough, as when driving a large capacitive load, the circuit phase margin is degraded and oscillation may occur.

With capacitive loads greater than approximately 50pF and the MAX442 configured as a unity-gain buffer, use an isolation resistor in series with the load, as shown in Figure 2. The resistor removes the pole from the loop response caused by the load capacitance.

Channel Switching Time/Transient

When the MAX442 multiplexer is switched from one channel to another, a small glitch will appear at the output. Figure 3 shows the results of putting a 0V to 5V pulse 100ns wide into A0.

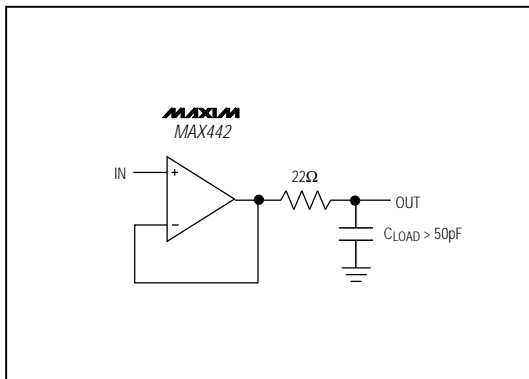

Figure 2. Capacitive-Load-Driving Circuit

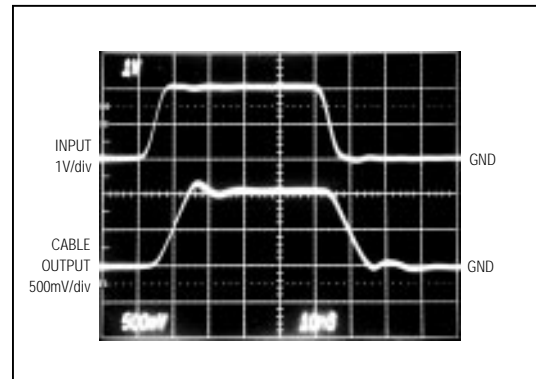

Figure 4. Pulse Response with $R_L = 100\Omega$ (50Ω back-terminated cable), $A_{VCL} = +1V/V$

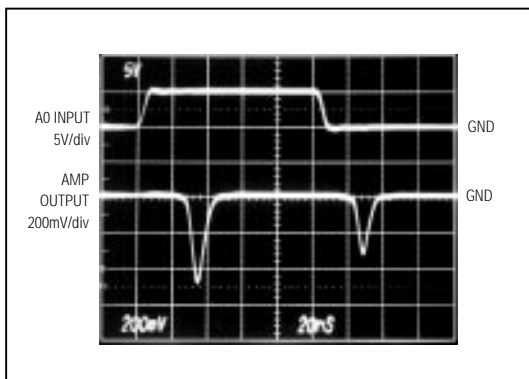

Figure 3. Output Switching Transient when Switching Between Two Grounded Inputs with $R_L = 100\Omega$

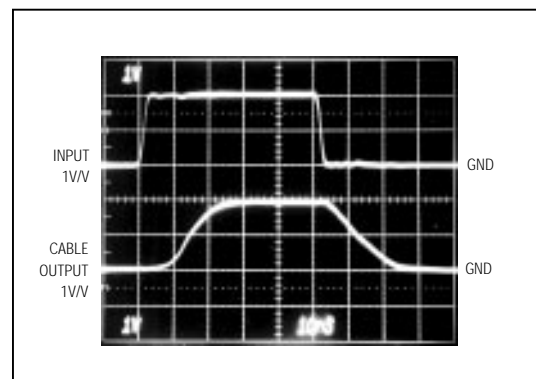

Figure 5. Pulse Response with $R_L = 100\Omega$ (50Ω back-terminated cable), $A_{VCL} = +2V/V$

140MHz, 2-Channel Video Multiplexer/Amplifier

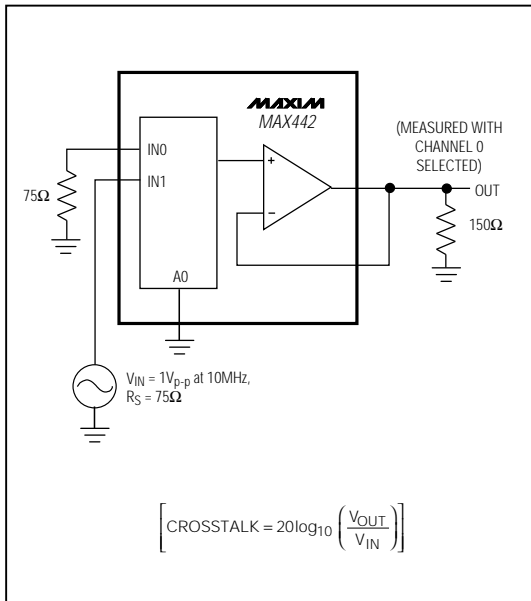

Figure 6. Crosstalk Test Circuit

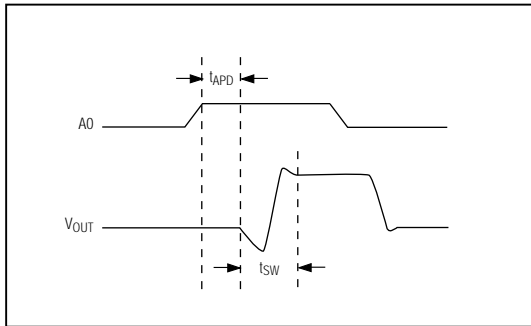
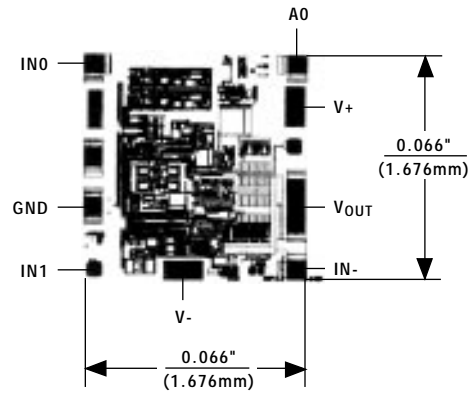

Figure 7. Switch Timing

Chip Topography



TRANSISTOR COUNT: 137
SUBSTRATE CONNECTED TO V-

MAX442

MAX442

140MHz, 2-Channel Video Multiplexer/Amplifier

Package Information

**Plastic DIP
PLASTIC
DUAL-IN-LINE
PACKAGE
(0.300 in.)**

DIM	INCHES		MILLIMETERS	
	MIN	MAX	MIN	MAX
A	—	0.200	—	5.08
A1	0.015	—	0.38	—
A2	0.125	0.175	3.18	4.45
A3	0.055	0.080	1.40	2.03
B	0.016	0.022	0.41	0.56
B1	0.045	0.065	1.14	1.65
C	0.008	0.012	0.20	0.30
D1	0.005	0.080	0.13	2.03
E	0.300	0.325	7.62	8.26
E1	0.240	0.310	6.10	7.87
e	0.100	—	2.54	—
eA	0.300	—	7.62	—
eB	—	0.400	—	10.16
L	0.115	0.150	2.92	3.81

PKG.	DIM	PINS	INCHES		MILLIMETERS	
			MIN	MAX	MIN	MAX
P	D	8	0.348	0.390	8.84	9.91
P	D	14	0.735	0.765	18.67	19.43
P	D	16	0.745	0.765	18.92	19.43
P	D	18	0.885	0.915	22.48	23.24
P	D	20	1.015	1.045	25.78	26.54
N	D	24	1.14	1.265	28.96	32.13

21-0043A

**Narrow SO
SMALL-OUTLINE
PACKAGE
(0.150 in.)**

DIM	INCHES		MILLIMETERS	
	MIN	MAX	MIN	MAX
A	0.053	0.069	1.35	1.75
A1	0.004	0.010	0.10	0.25
B	0.014	0.019	0.35	0.49
C	0.007	0.010	0.19	0.25
E	0.150	0.157	3.80	4.00
e	0.050		1.27	
H	0.228	0.244	5.80	6.20
L	0.016	0.050	0.40	1.27

DIM	PINS	INCHES		MILLIMETERS	
		MIN	MAX	MIN	MAX
D	8	0.189	0.197	4.80	5.00
D	14	0.337	0.344	8.55	8.75
D	16	0.386	0.394	9.80	10.00

21-0041A

Maxim cannot assume responsibility for use of any circuitry other than circuitry entirely embodied in a Maxim product. No circuit patent licenses are implied. Maxim reserves the right to change the circuitry and specifications without notice at any time.

8 Maxim Integrated Products, 120 San Gabriel Drive, Sunnyvale, CA 94086 (408) 737-7600