

Part Number: **XLMDKVG34M**

T-1(3mm) BI-COLOR INDICATOR LAMP

Features

- UNIFORM LIGHT OUTPUT.
- LOW POWER CONSUMPTION.
- 3 LEADS WITH ONE COMMON LEAD.
- I.C. COMPATIBLE.
- LONG LIFE - SOLID STATE RELIABILITY.
- RoHS COMPLIANT.

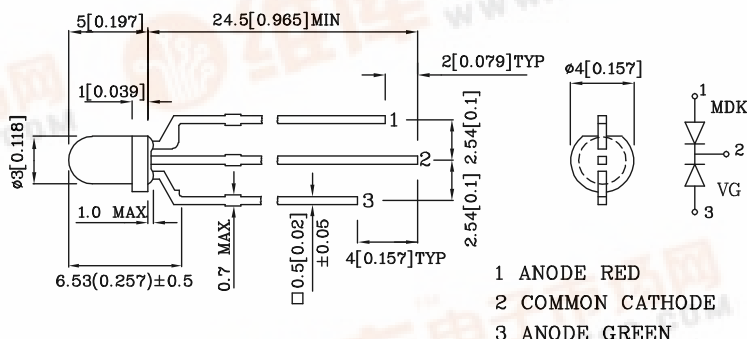

Notes:

1. All dimensions are in millimeters (inches).
2. Tolerance is $\pm 0.25(0.01)$ " unless otherwise noted.

Absolute Maximum Ratings (TA=25°C)		MDK (InGaA IP)	VG (InGaAlP)	Unit
Reverse Voltage	VR	5	5	V
Forward Current	IF	30	30	mA
Forward Current (peak) 1/10Duty Cycle 0.1ms Pulse Width	iFS	185	150	mA
Power Dissipation	PT	170	105	mW
Operating Temperature	TA	-40 ~ +85		°C
Storage Temperature	Tstg	-40 ~ +85		

Operating Characteristics (TA=25°C)		MDK (InGaA IP)	VG (InGaAlP)	Unit
Forward Voltage (typ.) (IF=20mA)	VF	1.95	2.1	V
Forward Voltage (max.) (IF=20mA)	VF	2.5	2.5	V
Reverse Current (VR=5V)	IR	10	10	uA
Wavelength of Peak Emission (IF=20mA)	λ P	650	574	nm
Wavelength of Dominant Emission (IF=20mA)	λ D	635	570	nm
Spectral Line Full Width At Half-Maximum (IF=20mA)	$\Delta\lambda$	28	20	nm
Capacitance (VF=0V, f=1MHz)	C	35	15	pF

Part Number	Emitting Color	Emitting Material	Lens-color	Luminous Intensity (IF=20mA) mcd	Wavelength nm λ P	Viewing Angle 2 θ 1/2
-------------	----------------	-------------------	------------	--	---------------------------------	---------------------------------

min. typ.

Red InGaAlP
Green InGaAlP

White Diffused

110 397 650
18 108 574

60°

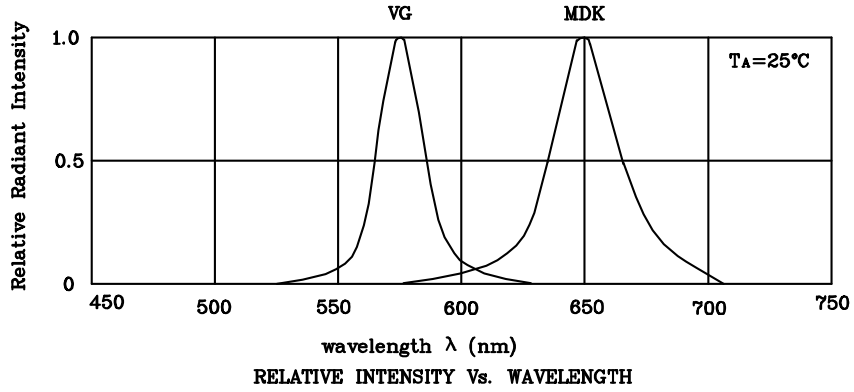

❖ MDK

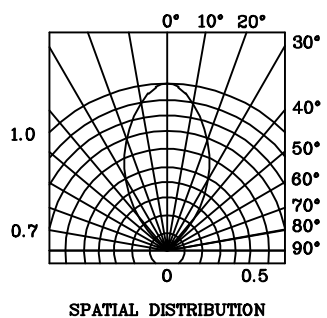
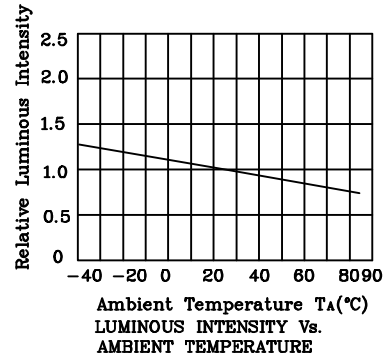
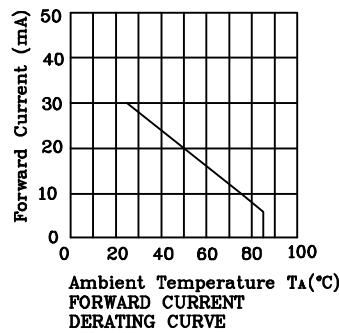
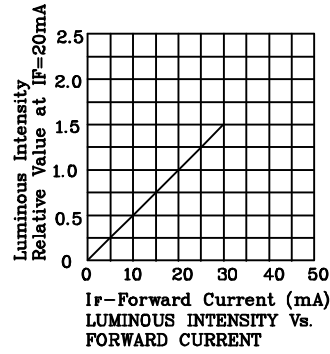
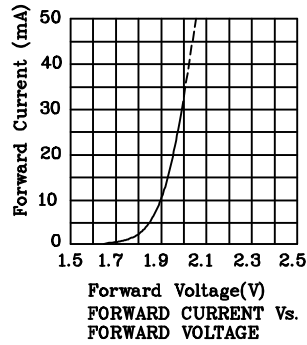

❖ VG

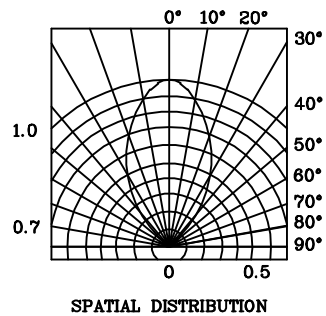
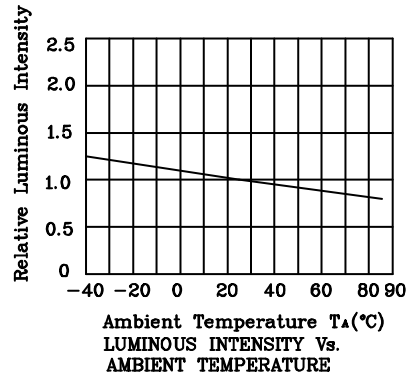
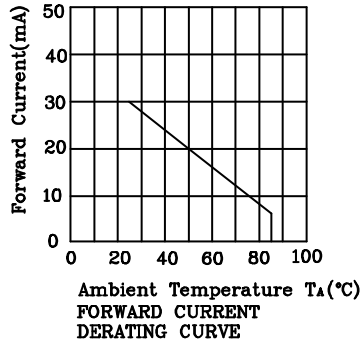
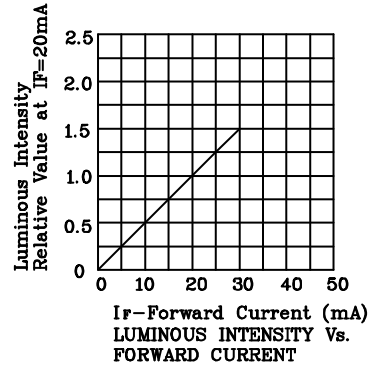
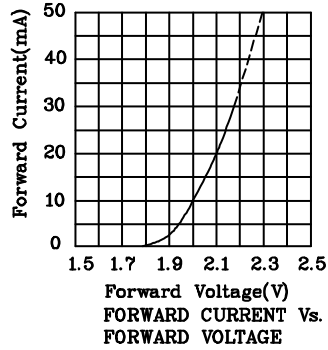

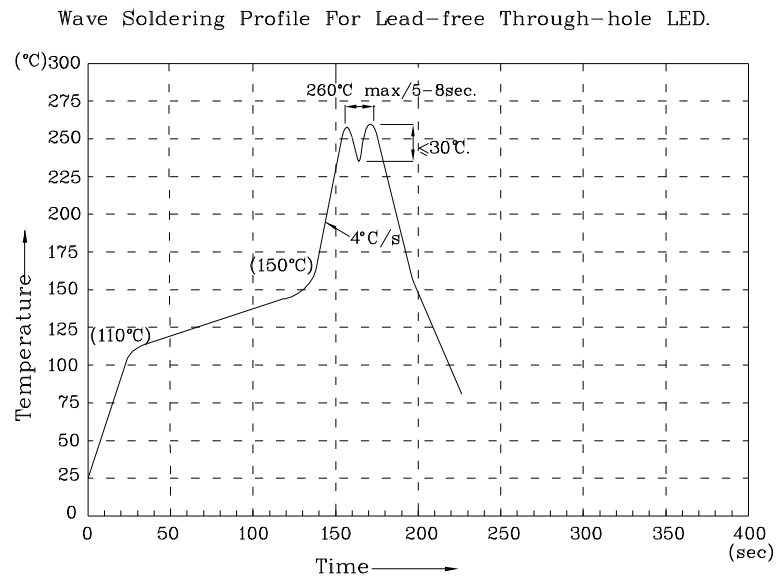

NOTE:

1. Recommend the wave temperature 245°C~260°C. The maximum soldering temperature should be less than 260°C.
2. Do not apply stress on epoxy resins when temperature is over 85 degree°C.
3. The soldering profile apply to the lead free soldering (Sn/Cu/Ag alloy).
4. No more than once.

Remarks:

If special sorting is required (e.g. binning based on forward voltage, luminous intensity, or wavelength), the typical accuracy of the sorting process is as follows:

1. Wavelength: +/-1nm
2. Luminous Intensity: +/-15%
3. Forward Voltage: +/-0.1V

Note: Accuracy may depend on the sorting parameters.