

Shock-Safe Fuseholder, 5 x 20 mm, horizontal, Slot/Fingergrip, SMD, IEC 60335-1

[查询"B43254F2187M000"供应商](#)

Fingergrip

250 VAC · 2.5W/10A (VDE)16A (UL/CSA)

**Description**

- Surface Mount Device
- Meets the new requirements of IEC 60335-1 Ed. 4.0 for appliances in unattended use (clause 30.2.3). This includes the enhanced requirements of glow wire tests acc. to IEC 60695-2-11 to -13. Order number: 3101.0071 / 3101.0076
- Cap is available slotted or fingergrip

Standards

- IEC 60127-6
- UL 4248-1 / UL 512
- CSA C22.2 no. 39

Approvals

- VDE License Number: 129098
- UL File Number: E39328

Applications

- Industrial electronic
- Household appliances
- Medical equipments

References

[General Product Information](#)
[Packaging Details](#)

Weblinks

[Approvals](#), [RoHS](#), [CHINA-RoHS](#), [e-Store](#), [Distributor-Stock-Check](#), [Accessories](#), [Product Change Notification \(PCN\)](#)

Technical Data

Shocksafe Category	PC2
Fuse-Link	5 x 20 mm
Mounting	PCB
Terminal	Solder SMT
Rated Voltage	250VAC
Rated Current	10A (VDE), 16A (UL/CSA)
Rated Power Acceptance IEC	2.5W / 10A @ Ta 23°C Admissible power acceptance at higher ambient temperature see derating curves
Degree of Protection	IP 40
Protection Class	Suitable for appliances with protection class 1 or 2 acc. to IEC 61140
Admissible Ambient Air Temp.	-40°C to 85°C
Climatic Category	40/085/21 acc. to IEC 60068-1
Material: Socket	Thermoplastic, black, UL 94V-0
Material: Terminals	Tin-Plated Copper Alloy
Unit Weight (Socket/Cap)	4.4 g
Storage Conditions	0°C to 60°C, max. 70% r.h.
Product Marking	 Type, Voltage, Power Acc./Current Rating, Approvals

Soldering Methods	Reflow
Solderability	245°C / 3 sec acc. to IEC 60068-2-58, Test Td
Resistance to Soldering Heat	260°C / 20 - 40 sec acc. to IPC/JEDEC J-STD-020D
Contact Resistance	< 5 mΩ at 20 mV
Dielectric Strength	> 3kV between L-N (50Hz; 1 min)
Impulse Withstand Voltage	> 2.5kV between L-N
Insulation Resistance	> 10 MΩ between L-N (500 VDC; 1 min)
Overvoltage Category	I - II acc. to IEC 60664-1
Pollution Degree	1 - 3 acc. to IEC 60664-1
Resistance to Vibration	acc. to IEC 60068-2-6, test Fc

查询"B43254F2187M000"供应商

Abmessungen

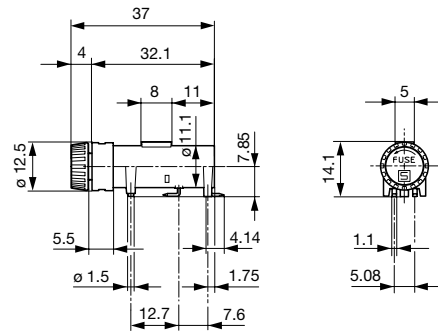
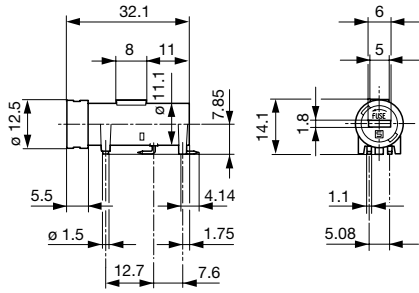

Variant 3101.0070

Variant 3101.0075

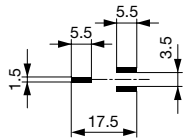

Soldering pads

Derating Curves for Fuseholders

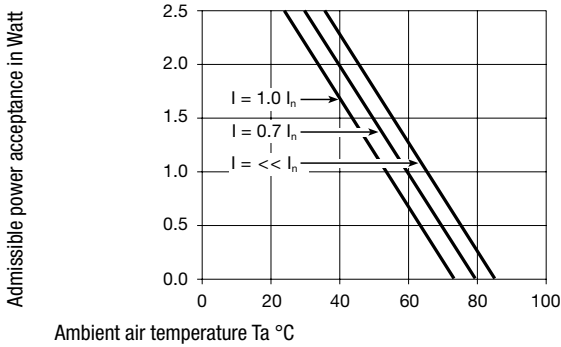

Variants

Holder	Cap	Material	Reflow Condition	Remark	Order Number
●	Slot Knob	Thermoplastic	-	will be replaced by 3101.0071	3101.0070
●	Slot Knob	Spec. Thermoplastic 2	acc. to JEDEC J-STD-020C, Tp=260 +/-5 °C, tp = 20-40 s	Approvals pending	3101.0071
●	Fingergrip	Thermoplastic	-	Will be replaced by 3101.0076	3101.0075
●	Fingergrip	Spec. Thermoplastic 2	acc. to JEDEC J-STD-020C, Tp=260 +/-5 °C, tp = 20-40 s	Approvals pending	3101.0076

Spec. thermoplastic meet the new requirements of IEC 60335-1 Ed. 4.0 for appliances in unattended use (clause 30.2.3). This includes the enhanced requirements of glow wire tests acc. to IEC 60695-2-11 to -13.

Packaging Unit xxxx.xxxx.D2 Blister Tape 38 cm Reel (250 pcs.)