

MODEL 44

4mm Square Multiturn Surface Mount Cermet Trimming Potentiometer

查询"44IR1K1FT7"供应商



1

ELECTRICAL

Standard Resistance Range, Ohms	10 to 2Meg
Standard Resistance Tolerance	±10% (<100 Ohms = ±20%)
Input Voltage, Maximum	300 Vdc or rms not to exceed power rating
Slider Current, Maximum	100mA or within rated power, whichever is less
Power Rating, Watts	0.25 at 85°C derating to 0 at 150°C
End Resistance, Maximum	1% or 2 Ohms, whichever is greater
Actual Electrical Travel, Turns, Nominal	9
Dielectric Strength	600Vrms
Insulation Resistance, Minimum	1,000 Megohms
Resolution	Essentially infinite
Contact Resistance Variation, Maximum	1% or 3 Ohms, whichever is greater

ENVIRONMENTAL

Seal	85°C Fluorinert® (No Leaks)
Temperature Coefficient, Maximum	±100ppm/°C (<100 Ohms = ±250ppm/°C)
Operating Temperature Range	-65°C to +150°C
Thermal Shock	5 cycles, -65°C to +150°C (2% ΔRT, 1% ΔVR)
Moisture Resistance	Ten 24 hour cycles (2% ΔRT, IR 10 Megohms Min.)
Shock, 6ms Sawtooth	100G's (1% ΔRT, 1% ΔVR)
Vibration	20G's, 10 to 2,000 Hz (1% ΔRT, 1% ΔVR)
Rotational Life	200 cycles (3% ΔRT, 1% CRV)
Load Life at 0.25 Watts	1,000 hours at 85°C (2% ΔRT, 1% CRV)
Resistance to Solder Heat	260°C for 10 sec. (1% ΔRT)
Temperature Exposure, Maximum	215°C for 3 min. (1% ΔRT)
Solderability	Per MIL-STD-202, Method 208

MECHANICAL

Mechanical Stops	Clutch action, both ends
Torque, Starting Maximum	3 oz.-in. (0.021 N-m)
Weight, Nominal	.01 oz. (0.3 grams)

Fluorinert® is a registered trademark of 3M Company.
Specifications subject to change without notice.



1-21

Model 44



TOP ADJUSTMENT (Inch/mm)

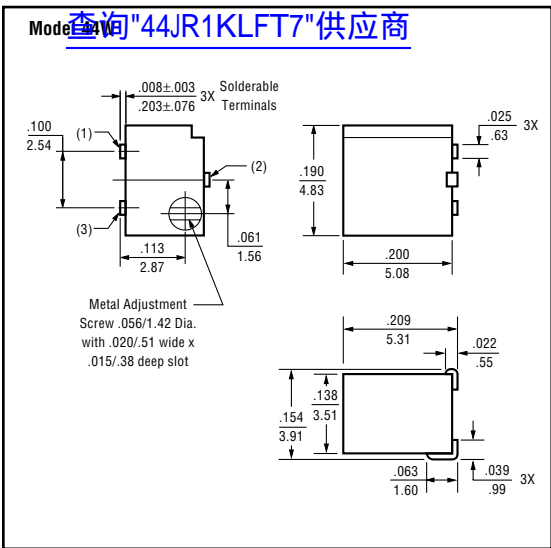

SIDE ADJUSTMENT (Inch/mm)

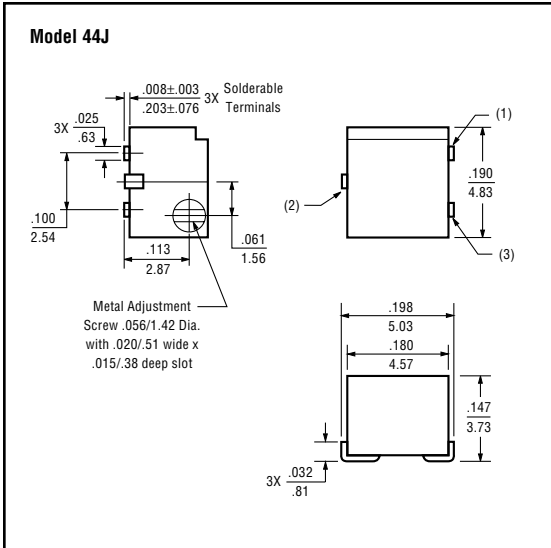

SOLDER PAD LAYOUT (Inch/mm)

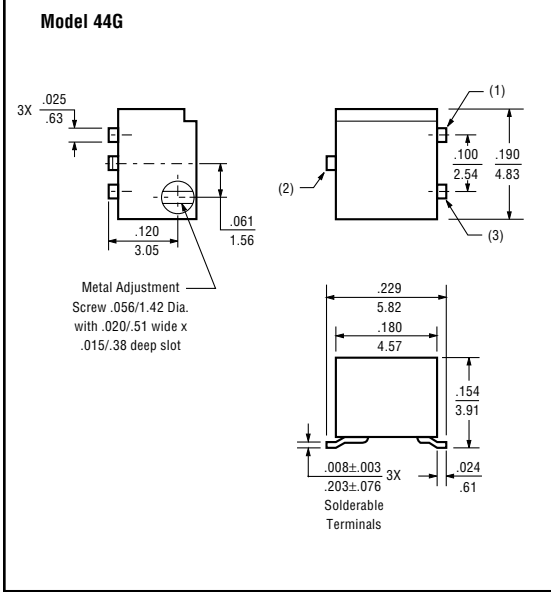
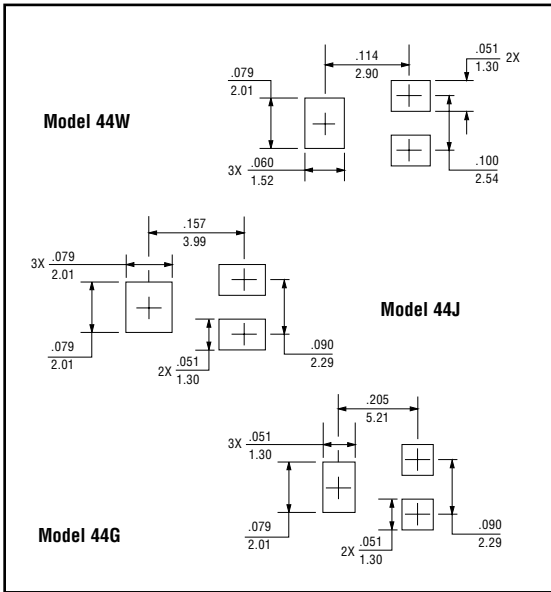

STANDARD RESISTANCE VALUES, OHMS

10	100	1K	10K	50K	250K	2Meg
20	200	2K	20K	100K	500K	
50	500	5K	25K	200K	1Meg	



FEATURES AND BENEFITS

- Space saving SMD Design for the most compact board designs
- Sealed to withstand aggressive water wash
- Long life - set and forget construction
- BI quality and reliability
- Available in top and side adjustment versions, J-Hook or gull wing termination

1

PACKAGING

Standard: Embossed Tape & Reel

All units oriented with #1 pin to the right of the direction of feed.

Tape	Pin Style	13" Reel		7" Reel	
		G & J	W	G & J	W
Width	=	12 mm	16 mm	12 mm	16 mm
Sprocket	=	4 mm Pitch	4 mm Pitch	4 mm Pitch	4 mm Pitch
Capacity	=	1,000 Units	1,000 Units	500 Units	250 Units
Reel Diameter	=	13" (330.2 mm)		7" (178 mm)	

Option: Anti-Static Tubes

All units oriented with #1 pin to same side.

Magazine Capacity = 100 Units

ORDERING INFORMATION

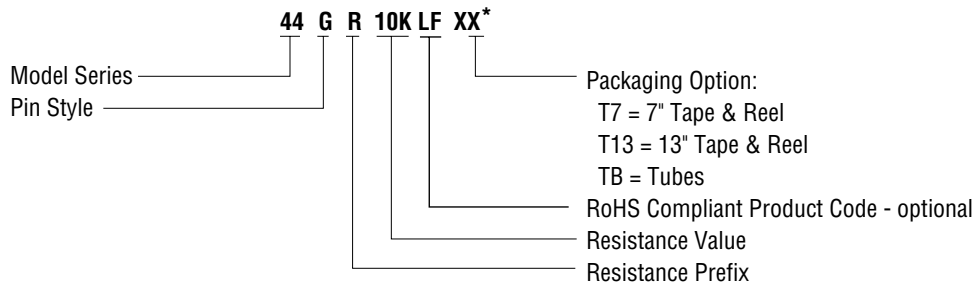

* Packaging option must be specified.

CIRCUIT DIAGRAM

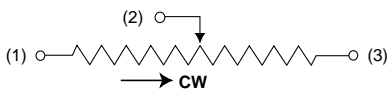

NOTES

Metric equivalents, based on 1 inch = 25.4mm are rounded to the same number of significant figures as in the original English units and are provided for general information only.

Tolerances unless otherwise specified:
 Linear = ± .012 inches (.30mm)
 Angular = ± 2 degrees

