

RECTIFIER ASSEMBLIES

Single Phase Bridges, 10 Amp,

Military Approved

JAN & JANTX 469-1
 JAN & JANTX 469-2
 JAN & JANTX 469-3

FEATURES

- Qualified to MIL-S-19500/469
- Current Rating: to 10A
- PIV: from 200 to 600V
- Surge Ratings of 100A
- Only Fused-in-Glass Diodes Used
- Controlled Avalanche Characteristics
- Aluminum Heat Sink Case, Electrically Insulated

DESCRIPTION

This series of military high-current single-phase bridge offer the utmost in reliability as required in military system designs. The TX series is assembled with diodes which have been subjected to 100% screening tests.

ABSOLUTE MAXIMUM RATINGS

Peak Inverse Voltage	200 to 600V
Maximum Average D.C. Output Current	
@ $T_C = +55^\circ\text{C}$	10A
@ $T_C = +100^\circ\text{C}$	6A
Non-Repetitive Sinusoidal Surge (8.3ms)	
@ $T_C = +55^\circ\text{C}$	100A
Operating and Storage Temperature Range, T_C	-65°C to $+150^\circ\text{C}$
Thermal Resistance Junction to Ambient	25°C/W
Junction to Case	5°C/W

Ltr	Dimensions			
	INCHES		MILLIMETERS	
	MIN.	MAX.	MIN.	MAX.
C ₁	.367	.375	9.32	9.53
C ₂	.350	.450	8.89	11.43
C ₃	.175	.225	4.45	5.72
φD ₁	.139	.149	3.53	3.78
φD ₂	.091	.101	2.31	2.57
φD ₃	.066	.076	1.68	1.93
H ₁		.570		14.48
H ₂		.370		9.40
L ₁	.088	.098	2.24	2.49
L ₂	.020	.030	.51	.76
W	.735	.750	18.67	19.05

MECHANICAL SPECIFICATIONS

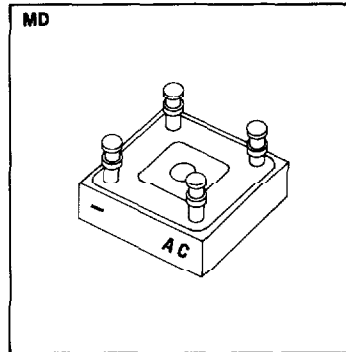
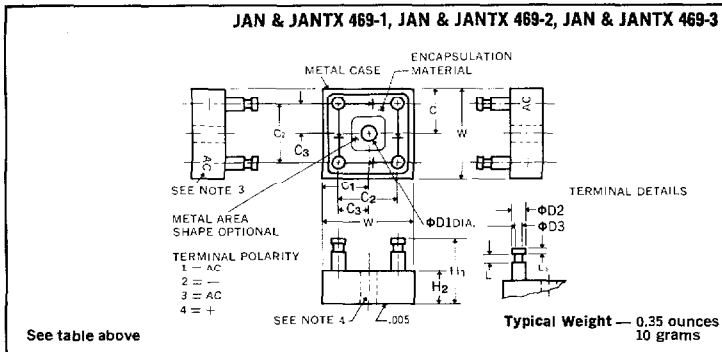

NOTES:

1. Metric equivalents (to the nearest .01 mm) are given for general information only and are based upon 1 inch = 25.4 mm.
2. Terminals shall be tinned.
3. Polarity shall be marked on the bridge body adjacent to terminals. Terminal numbers are for reference and do not have to be marked on the bridge; however, terminal (1) shall be indicated by a mechanical index such as a line, flattened corner, etc., visible from the top (terminal surface) of the device.
4. Point at which T_C is read shall be in metal part of a case as shown on drawing.

Microsemi Corp.
Watertown
 The diode experts

Electrical Specification (at 25°C unless noted)

3

Type	PIV Per Leg Volts	Minimum Reverse Breakdown Voltage Per Leg @ 50 μ A Volts	Maximum Forward Voltage Drop Per Leg†	Maximum Reverse Recovery Time† μ s	Maximum Leakage Current Per Leg @ PIV	
					$T_C = 25^\circ\text{C}$	$T_C = 100^\circ\text{C}$
					μ A	μ A
JAN & JANTX 469-1	200	240	1.35V @ 15.7A(pk)	2	2	125
JAN & JANTX 469-2	400	460			2	125
JAN & JANTX 469-3	600	660			2	125

*Maximum forward voltage drop is measured at a pulse width of 8.3ms.

†Measured in a reverse-recovery circuit switching from 0.5A forward to 1.0A reverse current recovering to 0.25A.

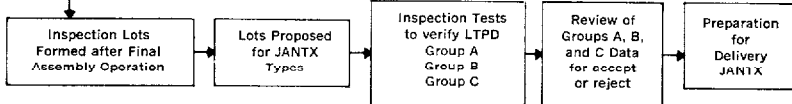
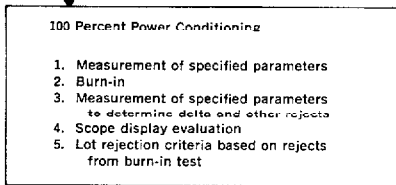
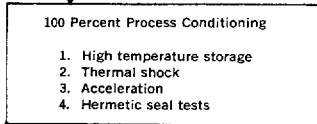
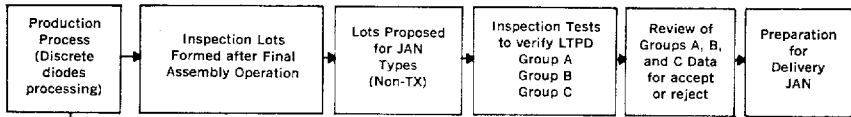
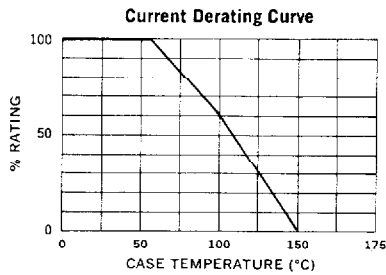
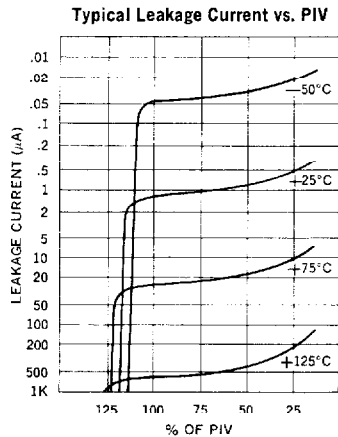
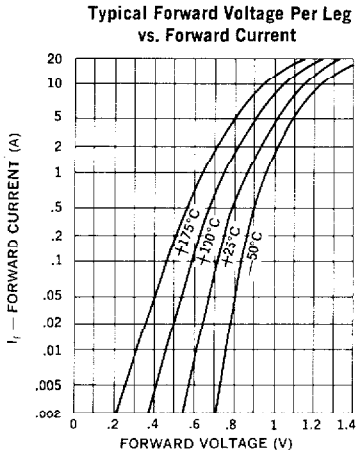

Reverse-Recovery Circuit

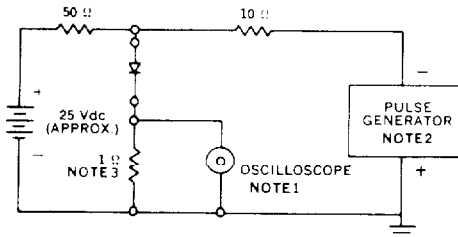

- NOTES:
1. Oscilloscope: Rise time \leq 3ns; input impedance = 50 Ω .
 2. Pulse Generator: Rise time \leq 8ns; source impedance 10 Ω .
 3. Current viewing resistor, non-inductive, coaxial recommended.