



**Series 800 "Mighty Mouse" with UN Mating Thread
Crimp Receptacle Ordering Information
800-010 and 800-011**



In-Line



Rear Panel Jam Nut Mount



Square Flange Mount

Integral Band Platform for direct attachment of a cable shield using a **BAND-IT®** strap. Install a boot, or overmold onto the band platform. An accessory thread is available for attaching strain reliefs and backshells.

Three Shell Options: Jam nut with o-ring for rear panel mounting, square flange or in-line receptacle for free-hanging cables.

HOW TO ORDER

Sample Part Number

800-011	-01	M	6-4	P	N																																																																																																																																	
Series	Shell Style	Shell Material / Finish	Shell Size- Insert Arrangement	Contact Type	Shell Key Position																																																																																																																																	
<p>800-010 Receptacle with Banding Platform</p>	<p>-01 In-Line</p>	<p>C Aluminum / Black Anodize (Non-Conductive) RoHS Compliant</p> <p>M Aluminum / Electroless Nickel RoHS Compliant</p>	<p>No. of Contacts</p> <table border="1"> <tr> <th>Arr.</th> <th>#23</th> <th>#20</th> <th>#16</th> <th>#12</th> </tr> <tr> <td>5-3</td> <td>3</td> <td></td> <td></td> <td></td> </tr> <tr> <td>6-1</td> <td></td> <td></td> <td>1</td> <td></td> </tr> <tr> <td>6-4</td> <td>4</td> <td></td> <td></td> <td></td> </tr> <tr> <td>6-7</td> <td>7</td> <td></td> <td></td> <td></td> </tr> <tr> <td>7-1</td> <td></td> <td></td> <td></td> <td>1</td> </tr> <tr> <td>7-10</td> <td>10</td> <td></td> <td></td> <td></td> </tr> <tr> <td>8-2</td> <td></td> <td></td> <td>2</td> <td></td> </tr> <tr> <td>8-13</td> <td>13</td> <td></td> <td></td> <td></td> </tr> <tr> <td>8-200</td> <td>4</td> <td>2</td> <td></td> <td></td> </tr> <tr> <td>9-4</td> <td></td> <td></td> <td>4</td> <td></td> </tr> <tr> <td>9-19</td> <td>19</td> <td></td> <td></td> <td></td> </tr> <tr> <td>9-200</td> <td>4</td> <td></td> <td>2</td> <td></td> </tr> <tr> <td>9-201</td> <td>8</td> <td>2</td> <td></td> <td></td> </tr> <tr> <td>10-5</td> <td></td> <td></td> <td>5</td> <td></td> </tr> <tr> <td>10-26</td> <td>26</td> <td></td> <td></td> <td></td> </tr> <tr> <td>10-200</td> <td>12</td> <td></td> <td></td> <td>1</td> </tr> <tr> <td>10-201</td> <td>4</td> <td></td> <td></td> <td>2</td> </tr> <tr> <td>10-202</td> <td>8</td> <td></td> <td>2</td> <td></td> </tr> <tr> <td>12-2</td> <td></td> <td></td> <td></td> <td>2</td> </tr> <tr> <td>12-3</td> <td></td> <td></td> <td></td> <td>3</td> </tr> <tr> <td>12-7</td> <td></td> <td></td> <td>7</td> <td></td> </tr> <tr> <td>12-37</td> <td>37</td> <td></td> <td></td> <td></td> </tr> <tr> <td>12-200</td> <td>6</td> <td></td> <td></td> <td>2</td> </tr> <tr> <td>12-201</td> <td>10</td> <td></td> <td></td> <td>2</td> </tr> </table>					Arr.	#23	#20	#16	#12	5-3	3				6-1			1		6-4	4				6-7	7				7-1				1	7-10	10				8-2			2		8-13	13				8-200	4	2			9-4			4		9-19	19				9-200	4		2		9-201	8	2			10-5			5		10-26	26				10-200	12			1	10-201	4			2	10-202	8		2		12-2				2	12-3				3	12-7			7		12-37	37				12-200	6			2	12-201	10			2	<p>Connector supplied with contacts</p> <p>P Pin</p> <p>S Socket</p> <p>Connector supplied without contacts</p> <p>A Pin</p> <p>B Socket Connector</p> <p>Connectors with contacts are supplied with signal and/or power crimp contacts. These contacts are not installed.</p> <p>Coaxial contacts and non-standard signal contacts are ordered separately.</p>	<p>N Normal</p> <p>X Pos. X</p> <p>Y Pos. Y</p> <p>Z Pos. Z</p>
			Arr.	#23	#20	#16	#12																																																																																																																															
			5-3	3																																																																																																																																		
			6-1			1																																																																																																																																
			6-4	4																																																																																																																																		
			6-7	7																																																																																																																																		
			7-1				1																																																																																																																															
			7-10	10																																																																																																																																		
			8-2			2																																																																																																																																
			8-13	13																																																																																																																																		
8-200	4	2																																																																																																																																				
9-4			4																																																																																																																																			
9-19	19																																																																																																																																					
9-200	4		2																																																																																																																																			
9-201	8	2																																																																																																																																				
10-5			5																																																																																																																																			
10-26	26																																																																																																																																					
10-200	12			1																																																																																																																																		
10-201	4			2																																																																																																																																		
10-202	8		2																																																																																																																																			
12-2				2																																																																																																																																		
12-3				3																																																																																																																																		
12-7			7																																																																																																																																			
12-37	37																																																																																																																																					
12-200	6			2																																																																																																																																		
12-201	10			2																																																																																																																																		
<p>800-011 Receptacle with Accessory Thread</p>	<p>-02 Square Flange for Front or Rear Mounting</p>	<p>NF Aluminum / Cadmium with Olive Drab Chromate</p> <p>ZN Aluminum / Zinc-Nickel with Olive Drab Chromate</p> <p>UCR Aluminum / Zinc-Cobalt with Black Chromate RoHS Compliant</p> <p>ZNU Aluminum / Zinc-Nickel with Black Chromate</p> <p>MT Aluminum / Nickel-PTFE RoHS Compliant</p> <p>Z1 Stainless Steel / Passivated RoHS Compliant</p>																																																																																																																																				
			<p>-07 Jam Nut for Rear Panel Mounting</p>																																																																																																																																			

Dimensions in inches (millimeters) and are subject to change without notice.

CAGE Code 06324

Printed in U.S.A.

© 2009 Glennair, Inc.

GLENNAIR, INC. • 1211 AIR WAY • GLENDALE, CA 91201-2497 • 818-247-6000 • FAX 818-500-9912

C-6

E-Mail: sales@glenair.com

Rev. 01-FEB-2009



Series 800 "Mighty Mouse" with UN Mating Thread Jam Nut Crimp Receptacle Dimensions 800-010-07 and 800-011-07



Integral Band Platform
800-010-07

Accessory Thread
800-011-07

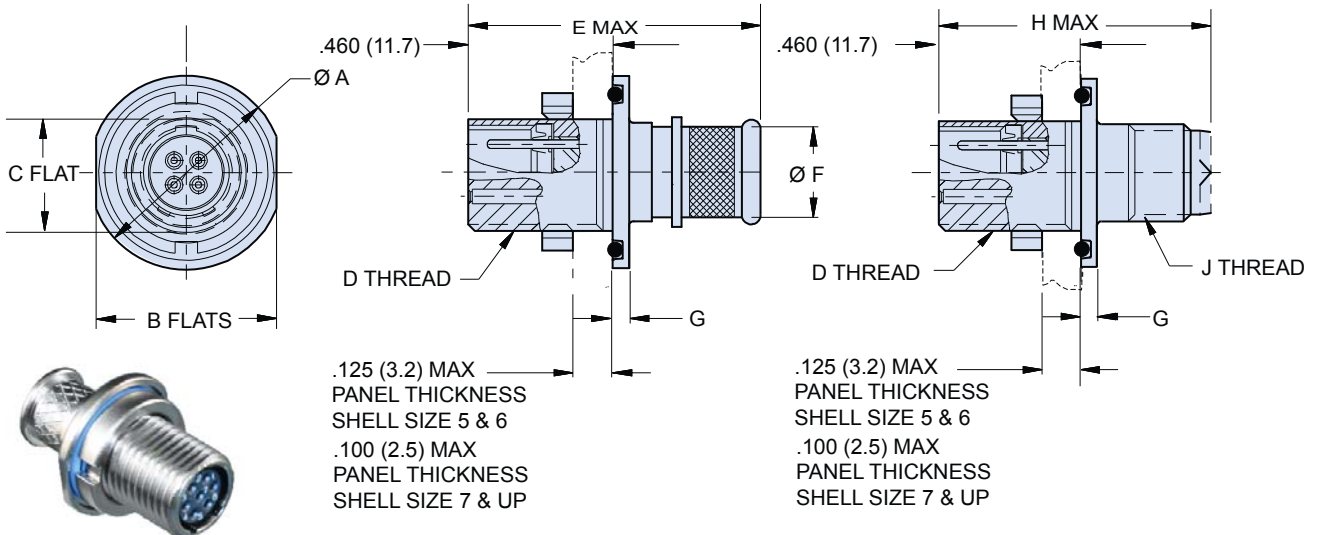

DIMENSIONS

Shell Size	Ø A		B		C		D Threads Mating	E Max.		Ø F		Ø G		H Max.		J Threads Accessory
	In.	mm.	In.	mm.	In.	mm.		In.	mm.	In.	mm.	In.	mm.	In.	mm.	
5	.541	13.74	.500	12.70	.285	7.24	.3125-28 UN-2A	.875	22.22	.230	5.84	.051	1.30	.850	21.59	.250-32 UNEF-2A
6	.610	15.49	.562	14.27	.352	8.94	.3750-28 UN-2A	.875	22.22	.286	7.26	.051	1.30	.850	21.59	.3125-32 UNEF-2A
7	.670	17.02	.635	16.13	.411	10.44	.4375-28 UNEF-2A	.875	22.22	.390	9.91	.093	2.36	.850	21.59	.4375-28 UNEF-2A
8	.775	19.69	.735	18.67	.473	12.01	.5000-32 UN-2A	.875	22.22	.445	11.30	.093	2.36	.850	21.59	.5000-28 UNEF-2A
9	.875	22.23	.806	20.47	.530	13.46	.5625-32 UN-2A	.875	22.22	.500	12.70	.093	2.36	.850	21.59	.5625-24 UNEF-2A
10	.980	24.89	.940	23.88	.604	15.34	.6250-32 UN-2A	.875	22.22	.565	14.35	.093	2.36	.850	21.59	.6250-24 UNEF-2A
12	1.062	26.97	.986	25.04	.712	18.08	.7500-28 UN-2A	.875	22.22	.650	16.51	.093	2.36	.850	21.59	.6875-24 UNEF-2A

SERIES 800 PANEL CUTOUTS

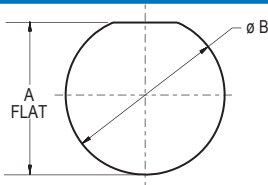

Shell Size	A Flat		Ø B	
	In.	mm.	In.	mm.
5	.302 / .298	7.67 / 7.57	.318	8.08
6	.365 / .361	9.27 / 9.17	.386	9.80
7	.424 / .420	10.77 / 10.67	.449	11.40
8	.486 / .482	12.34 / 12.24	.510	12.95
9	.543 / .539	13.79 / 13.69	.574	14.58
10	.617 / .613	15.67 / 15.57	.635	16.12
12	.725 / .721	18.42 / 18.31	.760	19.30

SERIES 800 KEY POSITIONS

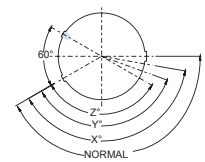
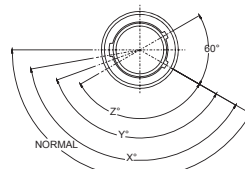

Key Position	Key Rotation
Normal (N)	150°
X	140°
Y	130°
Z	120°

Shell size 5 and 6: master key is located at top dead center for normal (N) position. Shell size 7 thru 12: master key is rotated 90° from TDC.

Dimensions in inches (millimeters) and are subject to change without notice.



Series 800 "Mighty Mouse" with UN Mating Thread Square Flange Crimp Receptacle Dimensions 800-010-02 and 800-011-02

C

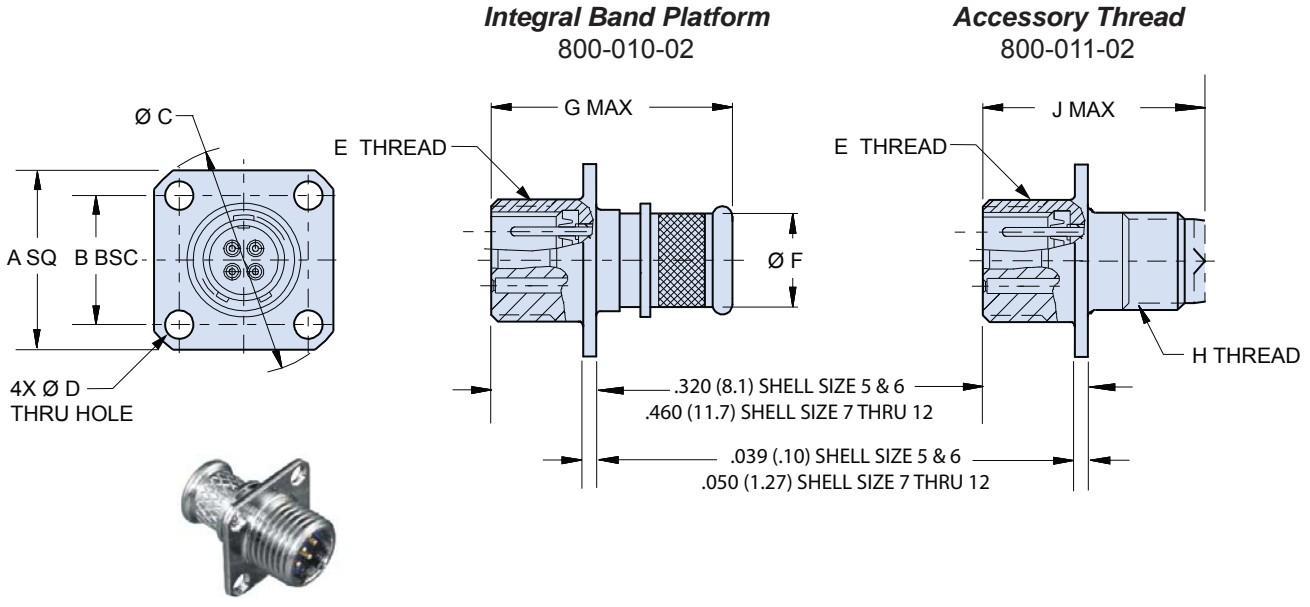

DIMENSIONS

Shell Size	A SQ		B		Ø C		Ø D		E Threads Mating	Ø F		G Max.		H Threads Accessory	J Max.	
	In.	mm.	In.	mm.	In.	mm.	In.	mm.		In.	mm.	In.	mm.		In.	mm.
5	.527	13.39	.363	9.22	.680	17.27	.094	2.39	.3125-28 UN-2A	.230	5.84	.750	19.05	.250-32 UNEF-2A	.725	18.42
6	.588	14.92	.423	10.74	.750	19.05	.094	2.39	.3750-28 UN-2A	.286	7.26	.750	19.05	.3125-32 UNEF-2A	.725	18.42
7	.650	16.51	.483	12.27	.830	21.08	.128	3.25	.4375-28 UNEF-2A	.390	9.91	.825	20.96	.4375-28 UNEF-2A	.800	20.32
8	.710	18.03	.542	13.77	.938	23.83	.128	3.25	.5000-32 UN-2A	.445	11.30	.825	20.96	.5000-28 UNEF-2A	.800	20.32
9	.938	23.83	.719	18.26	1.250	31.75	.128	3.25	.5625-32 UN-2A	.500	12.70	.825	20.96	.5625-24 UNEF-2A	.800	20.32
10	.938	23.83	.719	18.26	1.250	31.75	.128	3.25	.6250-32 UN-2A	.565	14.35	.825	20.96	.6250-24 UNEF-2A	.800	20.32
12	1.031	26.19	.812	20.62	1.375	34.93	.128	3.25	.7500-28 UN-2A	.650	16.51	.825	20.96	.6875-24 UNEF-2A	.800	20.32

SERIES 800 KEY POSITIONS

Key Position	Key Rotation		
Normal (N)	150°	<p>Plug Key Position</p>	<p>Receptacle Key Position</p>
X	140°		
Y	130°		
Z	120°		

Shell size 5 and 6: master key is located at top dead center for normal (N) position. Shell size 7 thru 12: master key is rotated 90° from TDC.

Dimensions in inches (millimeters) and are subject to change without notice.

Series 800 "Mighty Mouse" with UN Mating Thread In-Line Crimp Receptacle Dimensions 800-010-01 and 800-011-01



Integral Band Platform
800-010-01

Accessory Thread
800-011-01

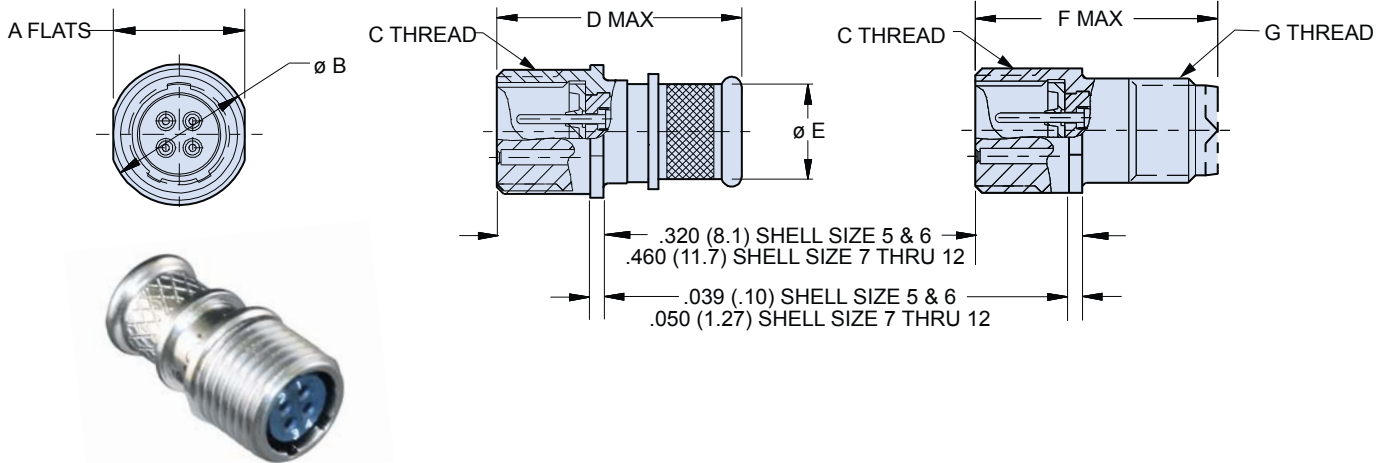

DIMENSIONS

Shell Size	A		Ø B		C Threads Mating	D Max.		Ø E		F Max.		G Threads Accessory
	In.	mm.	In.	mm.		In.	mm.	In.	mm.	In.	mm.	
5	.312	7.92	.355	9.02	.3125-28 UN-2A	.750	19.05	.230	5.84	.725	18.42	.250-32 UNEF-2A
6	.375	9.53	.400	10.16	.3750-28 UN-2A	.750	19.05	.286	7.26	.725	18.42	.3125-32 UNEF-2A
7	.445	11.30	.490	12.45	.4375-28 UNEF-2A	.825	20.96	.390	9.91	.800	20.32	.4375-28 UNEF-2A
8	.550	13.97	.600	15.24	.5000-32 UN-2A	.825	20.96	.445	11.30	.800	20.32	.5000-28 UNEF-2A
9	.613	15.57	.663	16.84	.5625-32 UN-2A	.825	20.96	.500	12.70	.800	20.32	.5625-24 UNEF-2A
10	.675	17.15	.725	18.42	.6250-32 UN-2A	.825	20.96	.565	14.35	.800	20.32	.6250-24 UNEF-2A
12	.800	20.32	.850	21.59	.7500-28 UN-2A	.825	20.96	.650	16.51	.800	20.32	.6875-24 UNEF-2A

SERIES 800 KEY POSITIONS

Key Position	Key Rotation	<p>Plug Key Position</p>	<p>Receptacle Key Position</p>
Normal (N)	150°		
X	140°		
Y	130°		
Z	120°		

Shell size 5 and 6: master key is located at top dead center for normal (N) position. Shell size 7 thru 12: master key is rotated 90° from TDC for normal position.

Dimensions in inches (millimeters) and are subject to change without notice.

This datasheet has been downloaded from:

www.EEworld.com.cn

Free Download

Daily Updated Database

100% Free Datasheet Search Site

100% Free IC Replacement Search Site

Convenient Electronic Dictionary

Fast Search System

www.EEworld.com.cn