

UNCONTROLLED DOCUMENT

[查询"SML-LX1610SIC/A"供应商](#)

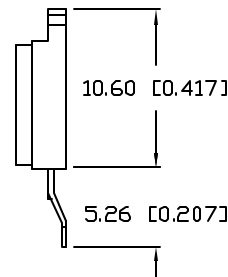
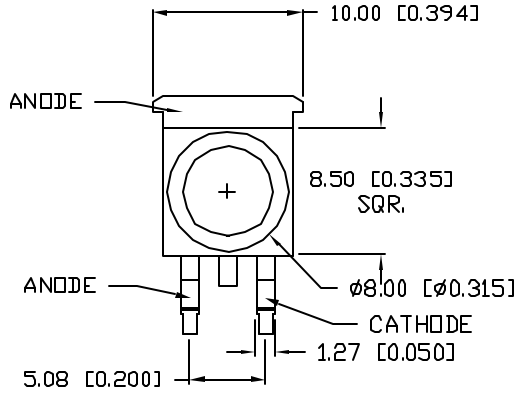
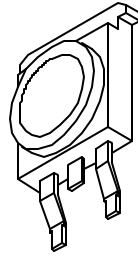
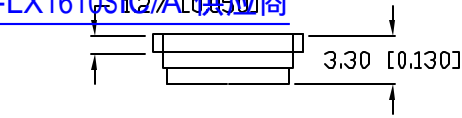

PART NUMBER		REV.
SML-LX1610SIC/A		A
REV.	E.C.N. NUMBER AND REVISION COMMENTS	DATE
A	E.C.N. #11391.	01.16.07

ELECTRO-OPTICAL CHARACTERISTICS $T_A=25^{\circ}\text{C}$ $I_f=350\text{mA}$

PARAMETER	SYMBOL	MIN	TYP	MAX	UNITS	TEST COND
PEAK WAVELENGTH			625		nm	
FORWARD VOLTAGE	V_f		2.1	3.2	V	$I_f=350\text{mA}$
REVERSE VOLTAGE	V_r	5			V	$I_r=10\mu\text{A}$
AXIAL INTENSITY(*1)	I_v		22		lm	$I_f=350\text{mA}$
VIEWING ANGLE			110		$2x \theta_{\text{theta}}$	
EMITTED COLOR:	RED					
EPOXY LENS FINISH:	WATER CLEAR					

LIMITS OF SAFE OPERATION AT 25°C

PARAMETER	SYMBOL	MAX	UNITS
PULSE FORWARD CURRENT	I_p	400	mA
STEADY CURRENT	I_F	350	mA
POWER DISSIPATION	P_D	1.1	W
OPERATING TEMP.	T_{OPR}	-20 TO +70	°C
STORAGE TEMP.	T_{STG}	-40 TO +85	°C

*DUTY 1/10 PULSE WIDTH 10ms

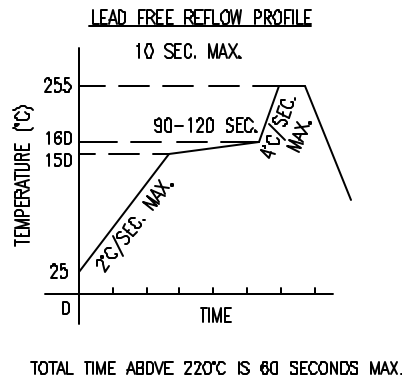

SOLDER PAD LAYOUT

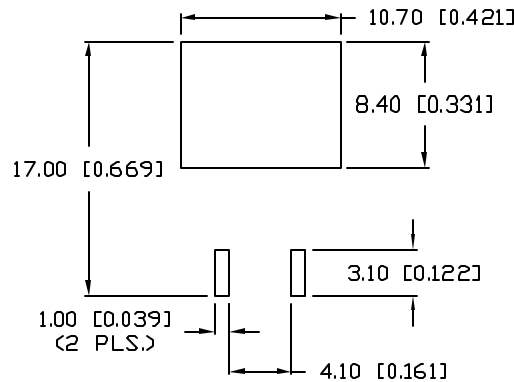

CAUTION: STATIC SENSITIVE DEVICE
FOLLOW PROPER E.S.D. HANDLING PROCEDURES
WHEN WORKING WITH THIS PART.



NOTES:

1. 50 PCS. IN EACH TUBE.

UNCONTROLLED DOCUMENT

*UNLESS OTHERWISE SPECIFIED TOLERANCES PER DECIMAL PRECISION ARE: X=±1 (±0.039), XX=±0.5 (±0.020), XXX=±0.25 (±0.010), XXXX=±0.127 (±0.005). LEAD SIZE=±0.05 (±0.002), LEAD LENGTH=±0.75 (±0.030), MIN=+0.00 DECIMAL PRECISION MAX.=+0.00 DECIMAL PRECISION

REV. A	PART NUMBER SML-LX1610SIC/A	CONFIDENTIAL INFORMATION THE INFORMATION CONTAINED IN THIS DOCUMENT IS THE PROPERTY OF LUMEX INC. EXCEPT AS SPECIFICALLY AUTHORIZED IN WRITING BY LUMEX INC, THE HOLDER OF THIS DOCUMENT SHALL KEEP ALL INFORMATION CONTAINED HEREIN CONFIDENTIAL AND SHALL PROTECT SAME IN WHOLE OR IN PART FROM DISCLOSURE AND DISSEMINATION TO ALL THIRD PARTIES.	LUMEX INC. 290 E. HELEN ROAD PALATINE, IL 60067-6976 PHONE: +1.847.359.2790 US WEB: www.lumex.com TW WEB: www.lumex.com.tw
10.60 x 10mm HIGH POWER LED, 625nm RED LED.		RELIABILITY NOTE OUR MANY YEARS OF EXPERIENCE DATA ACCUMULATION INDICATE THAT SOLDER HEAT IS A MAJOR CAUSE OF EARLY AND FUTURE FAILURE. PLEASE PAY ATTENTION TO YOUR SOLDERING PROCESS.	DRAWN BY: JC CHECKED BY: APPROVED BY: DATE: 8.31.06 PAGE: 1 OF 1 SCALE: N/A