



EPCOS

[查询"B43305A2158M007"供应商](#)

Aluminum electrolytic capacitors

Snap-in capacitors

Series/Type: B43305
Date: December 2006

General-purpose grade capacitors

Applications

- Switch-mode power supplies in industrial and entertainment electronics
- Uninterruptible power supplies

Features

- Extremely high CV product, ultra compact
- High ripple current capability
- Different case sizes available for each capacitance value
- Voltage derating ($0.93 \cdot V_R$) enables 105 °C operation, more details available upon request

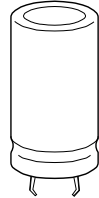

Construction

- Charge/discharge-proof, polar
- Aluminum case, fully insulated
- Snap-in solder pins to hold component in place on PC-board
- Minus pole marking on case surface
- Minus pole not insulated from case
- Overload protection by safety vent on the base

Terminals

- Standard version with 2 terminals, 2 lengths available: 6.3 and 4.5 mm
- 3 terminals to ensure correct insertion: length 4.5 mm



Specifications and characteristics in brief

Rated voltage V_R	200 ... 450 V DC	
Surge voltage V_S	$1.15 \cdot V_R$ (for $V_R \leq 250$ V DC) $1.10 \cdot V_R$ (for $V_R \geq 400$ V DC)	
Rated capacitance C_R	68 ... 3300 μ F	
Capacitance tolerance	$\pm 20\% \triangleq M$	
Dissipation factor $\tan \delta$ (20 °C, 120 Hz)	$V_R \leq 250$ V DC: $\tan \delta \leq 0.15$ $V_R \geq 400$ V DC: $\tan \delta \leq 0.20$	
Leakage current I_{leak} (5 min, 20 °C)	$I_{leak} \leq 0.3 \mu A \cdot \left(\frac{C_R}{\mu F} \cdot \frac{V_R}{V} \right)^{0.7} + 4 \mu A$	
Self-inductance ESL	Approx. 20 nH	
Useful life 85 °C, V_R , $I_{AC,R}$ 40 °C, V_R , $1.1 \cdot I_{AC,R}$	> 2000 h > 100000 h	Requirements: $\Delta C/C \leq \pm 30\%$ of initial value $\tan \delta \leq 3$ times initial specified limit $I_{leak} \leq$ initial specified limit
Voltage endurance test 85 °C, V_R	2000 h	Post test requirements: $\Delta C/C \leq \pm 10\%$ of initial value $\tan \delta \leq 1.3$ times initial specified limit $I_{leak} \leq$ initial specified limit
Vibration resistance test	To IEC 60068-2-6, test Fc: Displacement amplitude 0.35 mm, frequency range 10 Hz ... 55 Hz, acceleration max. 5 g, duration 3×2 h. Capacitor mounted by its body which is rigidly clamped to the work surface.	
IEC climatic category	To IEC 60068-1: $V_R \leq 250$ V DC: 40/085/56 (–40 °C/+85 °C/56 days damp heat test) $V_R \geq 400$ V DC: 25/085/56 (–25 °C/+85 °C/56 days damp heat test)	
Detail specification	Similar to CECC 30301-806	
Sectional specification	IEC 60384-4	



B43305

查询"B43305A2158M007"供应商

Ultra compact 85 °C

Dimensional drawings

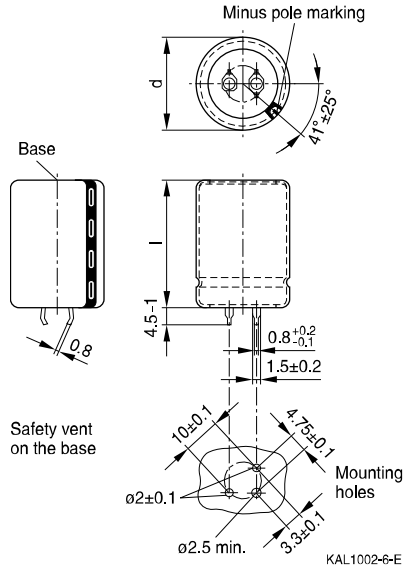
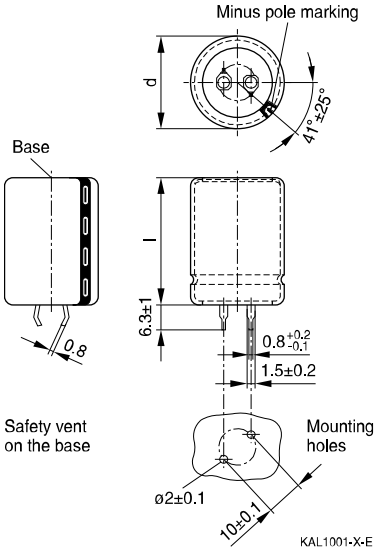

Snap-in terminals, length 6.3 ± 1 mm.
Also available in a shorter version with a length of $4.5 - 1$ mm. For packing mode and ordering example see next page.

Snap-in capacitors are also available with 3 terminals (length $4.5 - 1$ mm).
For packing mode and ordering example see next page.

Dimensions (mm)		Approx weight(g)	Packing units (pcs.)
d +1	l ±2		
22	25	9	160
22	30	12	160
22	35	15	160
22	40	18	160
22	45	20	160
22	50	24	160
25	25	13	130
25	30	17	130
25	35	19	130
25	40	22	130
25	45	25	130
25	50	29	130
25	55	32	130

Dimensions (mm)		Approx weight(g)	Packing units (pcs.)
d +1	l ±2		
30	25	17	80
30	30	23	80
30	35	29	80
30	40	36	80
30	45	41	80
30	50	46	80
30	55	53	80
35	25	22	60
35	30	29	60
35	35	36	60
35	40	41	60
35	45	56	60
35	50	70	60
35	55	81	60



Packing of snap-in capacitors



For ecological reasons the packing is pure cardboard. Components can be withdrawn (in full or in part) in the correct position for insertion.

Ordering codes for terminal styles

Snap-in capacitors Terminal versions	Identification in 3rd block of ordering code
Standard terminals (6.3 ±1) mm	M000
Short terminals (4.5 – 1) mm	M007
3 terminals (4.5 – 1) mm	M002

Ordering examples:

B43305A9107M007 } snap-in capacitor with short terminals
 B43305A9107M002 } snap-in capacitor with 3 terminals

B43305
[查询"B43305A2158M007"供应商](#)
Ultra compact 85 °C
Overview of available types

V_R (V DC)	200	250	400	450
	Case dimensions d × l (mm)			
C_R (μF)				
68			22 × 25	22 × 25
82			22 × 25	22 × 25
100			22 × 25	22 × 25
120			22 × 25	22 × 30 25 × 25
150			22 × 30	22 × 35 25 × 30
180			22 × 30 25 × 25	22 × 40 25 × 30 30 × 25
220			22 × 35 25 × 30	22 × 45 25 × 35 30 × 30
270		22 × 25	22 × 45 25 × 35 30 × 25	22 × 50 25 × 40 30 × 30 35 × 25
330	22 × 25	22 × 30 25 × 25	22 × 50 25 × 40 30 × 30 35 × 25	25 × 50 30 × 35 35 × 30
390	22 × 25	22 × 30 25 × 25	25 × 45 30 × 35 35 × 30	25 × 55 30 × 40 35 × 30
470	22 × 30 25 × 25	22 × 35 25 × 30	25 × 50 30 × 40 35 × 30	30 × 45 35 × 35
560	22 × 35 25 × 30	22 × 40 25 × 35 30 × 25	30 × 45 35 × 35	30 × 50 35 × 40
680	22 × 40 25 × 30 30 × 25	22 × 45 25 × 40 30 × 30	30 × 50 35 × 40	35 × 45
820	22 × 45 25 × 35 30 × 30	25 × 45 30 × 35 35 × 25	30 × 55 35 × 45	35 × 55



V _R (V DC)	200	250	400	450
	Case dimensions d × l (mm)			
C _R (μF)				
1000	22 × 50 25 × 40 30 × 30 35 × 25	25 × 50 30 × 35 35 × 30	35 × 50	
1200	25 × 45 30 × 35 35 × 30	25 × 55 30 × 40 35 × 35		
1500	25 × 55 30 × 40 35 × 30	30 × 50 35 × 40		
1800	30 × 45 35 × 35	30 × 55 35 × 45		
2200	30 × 55 35 × 40	35 × 50		
2700	35 × 50			
3300	35 × 55			

The capacitance and voltage ratings listed above are available in different cases upon request. Other voltage and capacitance ratings are also available upon request.



B43305

查询"B43305A2158M007"供应商

Ultra compact 85 °C

Technical data and ordering codes

C_R 100 Hz 20 °C μF	Case dimensions d × l mm	ESR _{typ} 100 Hz 20 °C mΩ	Z _{max} 10 kHz 20 °C mΩ	I _{AC,max} 100 Hz 60 °C A	I _{AC,R} ⁽¹⁾ 100 Hz 85 °C A	Ordering code (composition see below)
--------------------------------	-----------------------------------	---	---	---	--	--

V_R = 200 V DC

330	22 × 25	380	520	2.72	1.38	B43305A2337M00*
390	22 × 25	320	440	2.95	1.50	B43305A2397M00*
470	22 × 30	270	370	3.38	1.72	B43305A2477M00*
470	25 × 25	270	370	3.33	1.70	B43305B2477M00*
560	22 × 35	230	310	3.82	1.95	B43305A2567M00*
560	25 × 30	230	310	3.79	1.93	B43305B2567M00*
680	22 × 40	190	260	4.34	2.21	B43305A2687M00*
680	25 × 30	190	260	4.18	2.13	B43305B2687M00*
680	30 × 25	190	260	3.82	1.95	B43305C2687M00*
820	22 × 45	150	210	4.90	2.50	B43305A2827M00*
820	25 × 35	150	210	4.76	2.42	B43305B2827M00*
820	30 × 30	150	210	4.37	2.23	B43305C2827M00*
1000	22 × 50	130	180	5.54	2.83	B43305A2108M00*
1000	25 × 40	130	180	5.42	2.76	B43305B2108M00*
1000	30 × 30	130	180	4.83	2.46	B43305C2108M00*
1000	35 × 25	130	180	4.11	2.09	B43305D2108M00*
1200	25 × 45	110	150	6.10	3.11	B43305A2128M00*
1200	30 × 35	110	150	5.48	2.79	B43305B2128M00*
1200	35 × 30	110	150	4.99	2.54	B43305C2128M00*
1500	25 × 55	85	120	7.15	3.64	B43305A2158M00*
1500	30 × 40	85	120	6.74	3.44	B43305B2158M00*
1500	35 × 30	85	120	5.58	2.84	B43305C2158M00*
1800	30 × 45	70	100	7.59	3.87	B43305A2188M00*
1800	35 × 35	70	100	6.33	3.23	B43305B2188M00*
2200	30 × 55	60	80	8.80	4.49	B43305A2228M00*
2200	35 × 40	60	80	7.22	3.68	B43305B2228M00*
2700	35 × 50	45	65	8.44	4.30	B43305A2278M00*
3300	35 × 55	40	55	9.55	4.87	B43305A2338M00*

Composition of ordering code

* = Terminal style

0 = snap-in standard terminals (6.3 ±1) mm

2 = snap-in 3 terminals (4.5 – 1) mm

7 = snap-in short terminals (4.5 – 1) mm

1) 120-Hz conversion factor of ripple current: I_{AC} (120 Hz) = 1.03 · I_{AC} (100 Hz)

Technical data and ordering codes

C_R 100 Hz 20 °C μF	Case dimensions d × l mm	ESR _{typ} 100 Hz 20 °C mΩ	Z _{max} 10 kHz 20 °C mΩ	I _{AC,max} 100 Hz 60 °C A	I _{AC,R} ²⁾ 100 Hz 85 °C A	Ordering code (composition see below)
V_R = 250 V DC						
270	22 × 25	470	640	2.61	1.33	B43305E2277M00*
330	22 × 30	380	520	3.01	1.53	B43305E2337M00*
330	25 × 25	380	520	2.95	1.50	B43305F2337M00*
390	22 × 30	320	440	3.27	1.67	B43305E2397M00*
390	25 × 25	320	440	3.21	1.64	B43305F2397M00*
470	22 × 35	270	370	3.72	1.90	B43305E2477M00*
470	25 × 30	270	370	3.68	1.87	B43305F2477M00*
560	22 × 40	230	310	4.19	2.13	B43305E2567M00*
560	25 × 35	230	310	4.16	2.12	B43305F2567M00*
560	30 × 25	230	310	3.62	1.84	B43305G2567M00*
680	22 × 45	190	260	4.74	2.42	B43305E2687M00*
680	25 × 40	190	260	4.73	2.41	B43305F2687M00*
680	30 × 30	190	260	4.15	2.12	B43305G2687M00*
820	25 × 45	150	210	5.34	2.72	B43305E2827M00*
820	30 × 35	150	210	4.73	2.41	B43305F2827M00*
820	35 × 25	150	210	3.82	1.95	B43305G2827M00*
1000	25 × 50	130	180	6.04	3.08	B43305E2108M00*
1000	30 × 35	130	180	5.22	2.66	B43305F2108M00*
1000	35 × 30	130	180	4.69	2.39	B43305G2108M00*
1200	25 × 55	110	150	6.77	3.45	B43305E2128M00*
1200	30 × 40	110	150	6.29	3.21	B43305F2128M00*
1200	35 × 35	110	150	5.32	2.71	B43305G2128M00*
1500	30 × 50	85	120	7.41	3.78	B43305E2158M00*
1500	35 × 40	85	120	6.13	3.13	B43305F2158M00*
1800	30 × 55	70	100	8.31	4.24	B43305E2188M00*
1800	35 × 45	70	100	6.91	3.52	B43305F2188M00*
2200	35 × 50	60	80	7.83	3.99	B43305E2228M00*

Composition of ordering code

* = Terminal style

0 = snap-in standard terminals (6.3 ±1) mm

2 = snap-in 3 terminals (4.5 – 1) mm

7 = snap-in short terminals (4.5 – 1) mm

2) 120-Hz conversion factor of ripple current: I_{AC} (120 Hz) = 1.03 · I_{AC} (100 Hz)



B43305

查询"B43305A2158M007"供应商

Ultra compact 85 °C

Technical data and ordering codes

C_R	Case dimensions	ESR_{typ}	Z_{max}	$I_{AC,max}$	$I_{AC,R}^{(3)}$	Ordering code (composition see below)
100 Hz	d × l	100 Hz	10 kHz	100 Hz	100 Hz	
20 °C	mm	20 °C	20 °C	60 °C	85 °C	
μF		mΩ	mΩ	A	A	

$V_R = 400$ V DC

68	22 × 25	1990	2690	1.28	0.65	B43305A9686M00*
82	22 × 25	1650	2230	1.41	0.72	B43305A9826M00*
100	22 × 25	1360	1830	1.55	0.79	B43305A9107M00*
120	22 × 25	1130	1530	1.70	0.87	B43305A9127M00*
150	22 × 30	900	1220	1.98	1.01	B43305A9157M00*
180	22 × 30	750	1020	2.17	1.11	B43305A9187M00*
180	25 × 25	750	1020	2.18	1.11	B43305B9187M00*
220	22 × 35	620	830	2.49	1.27	B43305A9227M00*
220	25 × 30	620	830	2.51	1.28	B43305B9227M00*
270	22 × 45	500	680	2.92	1.49	B43305A9277M00*
270	25 × 35	500	680	2.89	1.47	B43305B9277M00*
270	30 × 25	500	680	2.79	1.42	B43305C9277M00*
330	22 × 50	410	560	3.31	1.69	B43305A9337M00*
330	25 × 40	410	560	3.29	1.68	B43305B9337M00*
330	30 × 30	410	560	3.22	1.64	B43305C9337M00*
330	35 × 25	410	560	3.04	1.55	B43305D9337M00*
390	25 × 45	350	470	3.68	1.87	B43305A9397M00*
390	30 × 35	350	470	3.62	1.85	B43305B9397M00*
390	35 × 30	350	470	3.67	1.87	B43305C9397M00*
470	25 × 50	290	390	4.14	2.11	B43305A9477M00*
470	30 × 40	290	390	4.37	2.23	B43305B9477M00*
470	35 × 30	290	390	4.03	2.05	B43305C9477M00*
560	30 × 45	240	330	4.91	2.50	B43305A9567M00*
560	35 × 35	240	330	4.56	2.32	B43305B9567M00*
680	30 × 50	200	270	5.55	2.83	B43305A9687M00*
680	35 × 40	200	270	5.18	2.64	B43305B9687M00*
820	30 × 55	170	230	6.23	3.18	B43305A9827M00*
820	35 × 45	170	230	5.85	2.98	B43305B9827M00*
1000	35 × 50	140	190	6.63	3.38	B43305A9108M00*

Composition of ordering code

* = Terminal style

0 = snap-in standard terminals (6.3 ±1) mm

2 = snap-in 3 terminals (4.5 – 1) mm

7 = snap-in short terminals (4.5 – 1) mm

3) 120-Hz conversion factor of ripple current: $I_{AC}(120\text{ Hz}) = 1.03 \cdot I_{AC}(100\text{ Hz})$

Technical data and ordering codes

\hat{C}_R	Case dimensions	ESR _{typ}	Z _{max}	I _{AC,max}	I _{AC,R} ⁴⁾	Ordering code (composition see below)
100 Hz	d × l	100 Hz	10 kHz	100 Hz	100 Hz	
20 °C	mm	20 °C	20 °C	60 °C	85 °C	
μF		mΩ	mΩ	A	A	

 $V_R = 450 \text{ V DC}$

68	22 × 25	1990	2800	1.37	0.70	B43305A5686M00*
82	22 × 25	1650	2320	1.50	0.76	B43305A5826M00*
100	22 × 25	1360	1900	1.66	0.85	B43305A5107M00*
120	22 × 30	1130	1590	1.90	0.97	B43305A5127M00*
120	25 × 25	1130	1590	1.90	0.97	B43305B5127M00*
150	22 × 35	900	1270	2.20	1.12	B43305A5157M00*
150	25 × 30	900	1270	2.21	1.13	B43305B5157M00*
180	22 × 40	750	1060	2.48	1.26	B43305A5187M00*
180	25 × 30	750	1060	2.42	1.23	B43305B5187M00*
180	30 × 25	750	1060	2.49	1.27	B43305C5187M00*
220	22 × 45	620	870	2.82	1.44	B43305A5227M00*
220	25 × 35	620	870	2.78	1.41	B43305B5227M00*
220	30 × 30	620	870	2.87	1.46	B43305C5227M00*
270	22 × 50	500	710	3.20	1.63	B43305A5277M00*
270	25 × 40	500	710	3.17	1.62	B43305B5277M00*
270	30 × 30	500	710	3.18	1.62	B43305C5277M00*
270	35 × 25	500	710	3.04	1.55	B43305D5277M00*
330	25 × 50	410	580	3.70	1.88	B43305A5337M00*
330	30 × 35	410	580	3.64	1.86	B43305B5337M00*
330	35 × 30	410	580	3.73	1.90	B43305C5337M00*
390	25 × 55	350	490	4.11	2.09	B43305A5397M00*
390	30 × 40	350	490	4.36	2.22	B43305B5397M00*
390	35 × 30	350	490	4.06	2.07	B43305C5397M00*
470	30 × 45	290	410	4.92	2.51	B43305A5477M00*
470	35 × 35	290	410	4.62	2.35	B43305B5477M00*
560	30 × 50	240	340	5.50	2.81	B43305A5567M00*
560	35 × 40	240	340	5.20	2.65	B43305B5567M00*
680	35 × 45	200	280	5.89	3.00	B43305A5687M00*
820	35 × 55	170	240	6.79	3.46	B43305A5827M00*

Composition of ordering code

* = Terminal style

0 = snap-in standard terminals (6.3 ± 1) mm

2 = snap-in 3 terminals (4.5 – 1) mm

7 = snap-in short terminals (4.5 – 1) mm

4) 120-Hz conversion factor of ripple current: I_{AC} (120 Hz) = 1.03 · I_{AC} (100 Hz)



B43305

查询"B43305A2158M007"供应商

Ultra compact 85 °C

Useful life

depending on ambient temperature T_A under ripple current operating conditions¹⁾

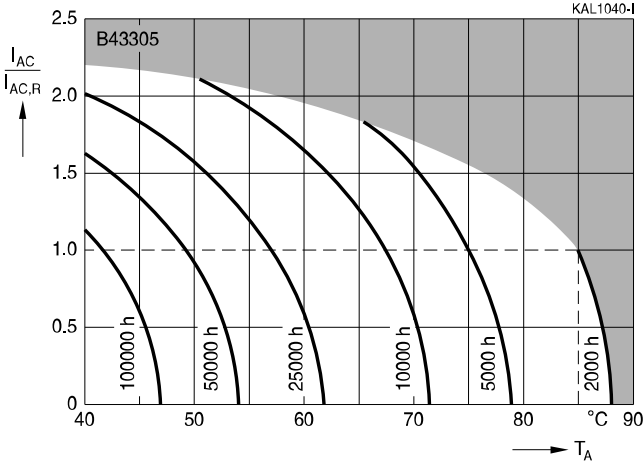

Frequency factor of permissible ripple current I_{AC} versus frequency f

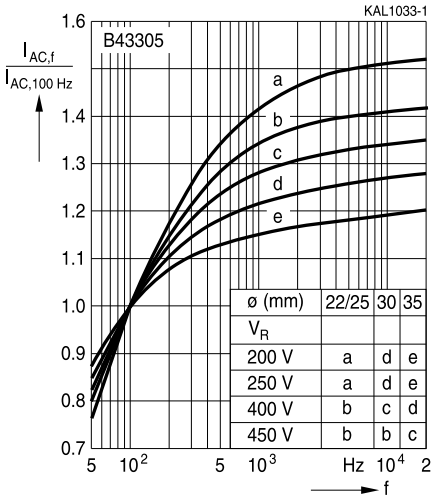

Frequency characteristics of ESR Typical behavior

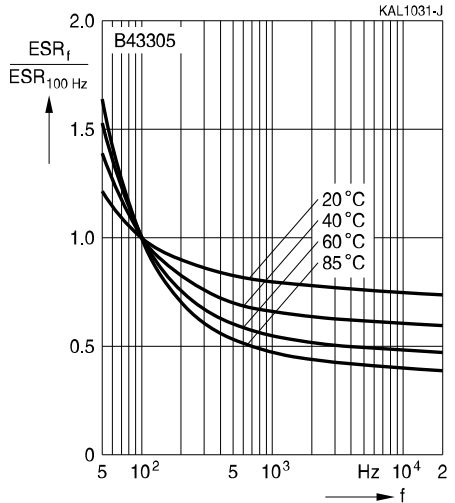

1) Refer to chapter "General technical information, 5.3 Calculation of useful life" for an explanation on how to interpret the useful life graphs.



Impedance Z versus frequency f

Typical behavior at 20 °C

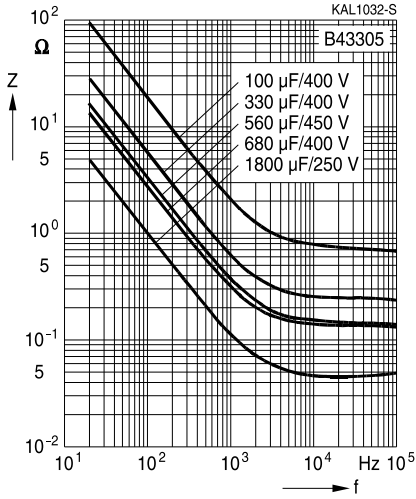



B43305

Ultra compact 85 °C

[查询"B43305A2158M007"供应商](#)

Cautions and warnings

Personal safety

The electrolytes used by EPCOS have not only been optimized with a view to the intended application, but also with regard to health and environmental compatibility. They do not contain any solvents that are detrimental to health, e.g. dimethyl formamide (DMF) or dimethyl acetamide (DMAC).

Furthermore, part of the high-voltage electrolytes used by EPCOS are self-extinguishing. They contain flame-retarding substances which will quickly extinguish any flame that may have been ignited.

As far as possible, EPCOS does not use any dangerous chemicals or compounds to produce operating electrolytes. However, in exceptional cases, such materials must be used in order to achieve specific physical and electrical properties because no safe substitute materials are currently known. However, the amount of dangerous materials used in our products has been limited to an absolute minimum. Nevertheless, the following rules should be observed when handling Al electrolytic capacitors:

- Any escaping electrolyte should not come into contact with eyes or skin.
- If electrolyte does come into contact with the skin, wash the affected parts immediately with running water. If the eyes are affected, rinse them for 10 minutes with plenty of water. If symptoms persist, seek medical treatment.
- Avoid breathing in electrolyte vapor or mists. Workplaces and other affected areas should be well ventilated. Clothing that has been contaminated by electrolyte must be changed and rinsed in water.



Product safety

The table below summarize the safety instructions that must be observed without fail. A detailed description can be found in the relevant sections of chapter "General technical information".

Topic	Safety information	Reference Chapter "General technical information"
Polarity	Make sure that polar capacitors are connected with the right polarity.	1 "Basic construction of aluminum electrolytic capacitors"
Reverse voltage	Voltages polarity classes should be prevented by connecting a diode.	3.1.6 "Reverse voltage"
Upper category temperature	Do not exceed the upper category temperatur.	7.2 "Maximum permissible operating temperature"
Maintenance	Make periodic inspections of the capacitors. Before the inspection, make sure that the power supply is turned off and carefully discharge the electricity of the capacitors. Do not apply any mechanical stress to the capacitor terminals.	10 "Maintenance"
Mounting position of screw terminal capacitors	Do not mount the capacitor with the terminals (safety vent) upside down.	11.1. "Mounting positions of capacitors with screw terminals"
Mounting of single-ended capacitors	The internal structure of single-ended capacitors might be damaged if excessive force is applied to the lead wires. Avoid any compressive, tensile or flexural stress. Do not move the capacitor after soldering to PC board. Do not pick up the PC board by the soldered capacitor. Do not insert the capacitor on the PC board with a hole space different to the lead space specified.	11.4 "Mounting considerations for single-ended capacitors"
Robustness of terminals	The following maximum tightening torques must not be exceeded when connecting screw terminals: M5: 2 Nm M6: 2.5 Nm	11.3 "Mounting torques"
Soldering	Do not exceed the specified time or temperature limits during soldering.	11.5 "Soldering"



B43305

Ultra compact 85 °C

[查询"B43305A2158M007"供应商](#)

Topic	Safety information	Reference Chapter "General technical information"
Soldering, cleaning agents	Do not allow halogenated hydrocarbons to come into contact with aluminum electrolytic capacitors.	11.6 "Cleaning agents"
Passive flammability	Avoid external energy, such as fire or electricity.	8.1 "Passive flammability"
Active flammability	Avoid overload of the capacitors.	8.2 "Active flammability"
		Reference Chapter "Capacitors with screw terminals"
Breakdown strength of insulating sleeves	Do not damage the insulating sleeve, especially when ring clips are used for mounting.	"Screw terminals - accessories"

The following applies to all products named in this publication:

1. Some parts of this publication contain **statements about the suitability of our products for certain areas of application**. These statements are based on our knowledge of typical requirements that are often placed on our products in the areas of application concerned. We nevertheless expressly point out **that such statements cannot be regarded as binding statements about the suitability of our products for a particular customer application**. As a rule, EPCOS is either unfamiliar with individual customer applications or less familiar with them than the customers themselves. For these reasons, it is always ultimately incumbent on the customer to check and decide whether an EPCOS product with the properties described in the product specification is suitable for use in a particular customer application.
2. We also point out that **in individual cases, a malfunction of passive electronic components or failure before the end of their usual service life cannot be completely ruled out in the current state of the art, even if they are operated as specified**. In customer applications requiring a very high level of operational safety and especially in customer applications in which the malfunction or failure of a passive electronic component could endanger human life or health (e.g. in accident prevention or life-saving systems), it must therefore be ensured by means of suitable design of the customer application or other action taken by the customer (e.g. installation of protective circuitry or redundancy) that no injury or damage is sustained by third parties in the event of malfunction or failure of a passive electronic component.
3. **The warnings, cautions and product-specific notes must be observed**.
4. In order to satisfy certain technical requirements, **some of the products described in this publication may contain substances subject to restrictions in certain jurisdictions (e.g. because they are classed as "hazardous")**. Useful information on this will be found in our Material Data Sheets on the Internet (www.epcos.com/material). Should you have any more detailed questions, please contact our sales offices.
5. We constantly strive to improve our products. Consequently, **the products described in this publication may change from time to time**. The same is true of the corresponding product specifications. Please check therefore to what extent product descriptions and specifications contained in this publication are still applicable before or when you place an order. We also **reserve the right to discontinue production and delivery of products**. Consequently, we cannot guarantee that all products named in this publication will always be available.
6. Unless otherwise agreed in individual contracts, **all orders are subject to the current version of the "General Terms of Delivery for Products and Services in the Electrical Industry" published by the German Electrical and Electronics Industry Association (ZVEI)**.
7. The trade names EPCOS, EPCOS-JONES, BAOKE, Alu-X, CeraDiode, CSSP, MLSC, PhaseCap, PhaseMod, SIFERRIT, SIFI, SIKOREL, SilverCap, SIMID, SIOV, SIP5D, SIP5K, UltraCap, WindCap are **trademarks registered or pending** in Europe and in other countries. Further information will be found on the Internet at www.epcos.com/trademarks.