

2.5V/3.3V 16-bit transceiver (3-State)

[查询 74ALVT16245DL-T 供应商](#)

74ALVT16245

FEATURES

- 16-bit bidirectional bus interface
- 5V I/O Compatible
- 3-State buffers
- Output capability: +64mA/-32mA
- TTL input and output switching levels
- Bus-hold data inputs eliminate the need for external pull-up resistors to hold unused inputs
- Live insertion/extraction permitted
- Power-up 3-State
- No bus current loading when output is tied to 5V bus
- Latch-up protection exceeds 500mA per JEDEC Std 17
- ESD protection exceeds 2000V per MIL STD 883 Method 3015 and 400V per Machine Model

DESCRIPTION

The 74ALVT16245 is a high-performance BiCMOS product designed for V_{CC} operation at 2.5V or 3.3V with I/O compatibility up to 5V.

This device is a 16-bit transceiver featuring non-inverting 3-State bus compatible outputs in both send and receive directions. The control function implementation minimizes external timing requirements. The device features an Output Enable (\overline{OE}) input for easy cascading and a Direction (DIR) input for direction control.

QUICK REFERENCE DATA

SYMBOL	PARAMETER	CONDITIONS $T_{amb} = 25^{\circ}C$	TYPICAL		UNIT
			2.5V	3.3V	
t_{PLH} t_{PHL}	Propagation delay nAx to nBx or nBx to nAx	$C_L = 50pF$	1.7 1.9	1.5 1.5	ns
C_{IN}	Input capacitance DIR, \overline{OE}	$V_I = 0V$ or V_{CC}	3	3	pF
$C_{I/O}$	I/O pin capacitance	$V_{I/O} = 0V$ or V_{CC}	9	9	pF
I_{CCZ}	Total supply current	Outputs disabled	40	70	μA

ORDERING INFORMATION

PACKAGES	TEMPERATURE RANGE	OUTSIDE NORTH AMERICA	NORTH AMERICA	DWG NUMBER
48-Pin Plastic SSOP Type III	-40°C to +85°C	74ALVT16245 DL	AV16245 DL	SOT370-1
48-Pin Plastic TSSOP Type II	-40°C to +85°C	74ALVT16245 DGG	AV16245 DGG	SOT362-1

LOGIC SYMBOL

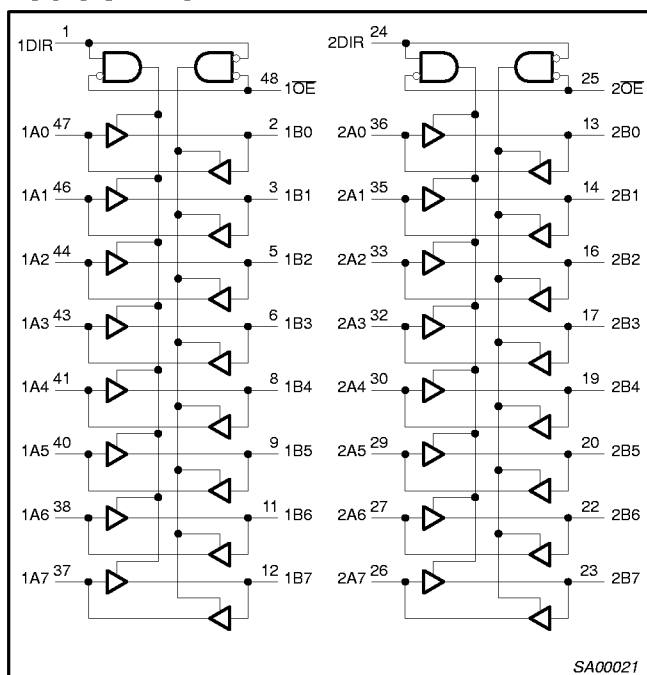

LOGIC SYMBOL (IEEE/IEC)

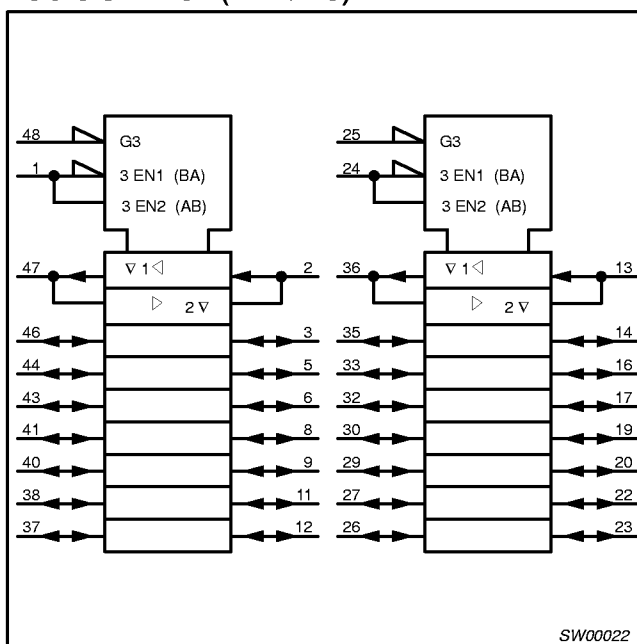

2.5V/3.3V 16-bit transceiver (3-State)

74ALVT16245

[查询 74ALVT16245DL-T 供应商](#)

PIN CONFIGURATION

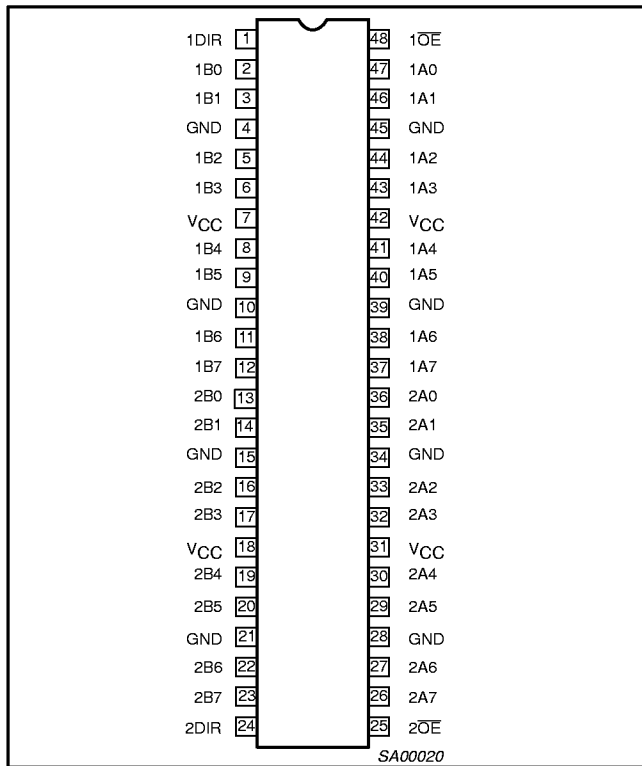

PIN DESCRIPTION

PIN NUMBER	SYMBOL	NAME AND FUNCTION
1, 24	nDIR	Direction control input
47, 46, 44, 43, 41, 40, 38, 37, 36, 35, 33, 32, 30, 29, 27, 26	nA0 – nA7	Data inputs/outputs (A side)
2, 3, 5, 6, 8, 9, 11, 12, 13, 14, 16, 17, 19, 20, 22, 23	nB0 – nB7	Data inputs/outputs (B side)
25, 48	nOE	Output enable input (active-Low)
4, 10, 15, 21, 28, 34, 39, 45	GND	Ground (0V)
7, 18, 31, 42	VCC	Positive supply voltage

FUNCTION TABLE

INPUTS		INPUTS/OUTPUTS	
nOE	nDIR	nAx	nBx
L	L	nAx = nBx	Inputs
L	H	Inputs	nBx = nAx
H	X	Z	Z

H = High voltage level
 L = Low voltage level
 X = Don't care
 Z = High Impedance "off" state

ABSOLUTE MAXIMUM RATINGS^{1, 2}

SYMBOL	PARAMETER	CONDITIONS	RATING	UNIT
VCC	DC supply voltage		-0.5 to +4.6	V
IIK	DC input diode current	V _I < 0	-50	mA
V _I	DC input voltage ³		-0.5 to +7.0	V
IOK	DC output diode current	V _O < 0	-50	mA
V _{OUT}	DC output voltage ³	Output in Off or High state	-0.5 to +7.0	V
I _{OUT}	DC output current	Output in Low state	128	mA
		Output in High state	-64	
T _{stg}	Storage temperature range		-65 to +150	°C

NOTES:

- Stresses beyond those listed may cause permanent damage to the device. These are stress ratings only and functional operation of the device at these or any other conditions beyond those indicated under "recommended operating conditions" is not implied. Exposure to absolute-maximum-rated conditions for extended periods may affect device reliability.
- The performance capability of a high-performance integrated circuit in conjunction with its thermal environment can create junction temperatures which are detrimental to reliability. The maximum junction temperature of this integrated circuit should not exceed 150°C.
- The input and output negative voltage ratings may be exceeded if the input and output clamp current ratings are observed.

2.5V/3.3V 16-bit transceiver (3-State)

74ALVT16245

[查询 74ALVT16245DL-T 供应商](#)

RECOMMENDED OPERATING CONDITIONS

SYMBOL	PARAMETER	2.5V RANGE LIMITS		3.3V RANGE LIMITS		UNIT
		MIN	MAX	MIN	MAX	
V _{CC}	DC supply voltage	2.3	2.7	3.0	3.6	V
V _I	Input voltage	0	5.5	0	5.5	V
V _{IH}	High-level input voltage	1.7		2.0		V
V _{IL}	Input voltage		0.7		0.8	V
I _{OH}	High-level output current		-8		-32	mA
I _{OL}	Low-level output current		8		32	mA
	Low-level output current; current duty cycle ≤ 50%; f ≥ 1kHz		24		64	
Δt/Δv	Input transition rise or fall rate; Outputs enabled		10		10	ns/V
T _{amb}	Operating free-air temperature range	-40	+85	-40	+85	°C

DC ELECTRICAL CHARACTERISTICS (3.3V ± 0.3V RANGE)

SYMBOL	PARAMETER	TEST CONDITIONS	LIMITS			UNIT
			Temp = -40°C to +85°C			
			MIN	TYP ¹	MAX	
V _{IK}	Input clamp voltage	V _{CC} = 3.0V; I _{IK} = -18mA		-0.85	-1.2	V
V _{OH}	High-level output voltage	V _{CC} = 3.0 to 3.6V; I _{OH} = -100μA	V _{CC} -0.2	V _{CC}		V
		V _{CC} = 3.0V; I _{OH} = -32mA	2.0	2.3		
V _{OL}	Low-level output voltage	V _{CC} = 3.0V; I _{OL} = 100μA		0.07	0.2	V
		V _{CC} = 3.0V; I _{OL} = 16mA		0.25	0.4	
		V _{CC} = 3.0V; I _{OL} = 32mA		0.3	0.5	
		V _{CC} = 3.0V; I _{OL} = 64mA		0.4	0.55	
I _I	Input leakage current	V _{CC} = 3.6V; V _I = V _{CC} or GND	Control pins	0.1	±1	μA
		V _{CC} = 0 or 3.6V; V _I = 5.5V		0.1	10	
		V _{CC} = 3.6V; V _I = 5.5V	Data pins ⁴	0.1	20	
		V _{CC} = 3.6V; V _I = V _{CC}		0.5	10	
		V _{CC} = 3.6V; V _I = 0		0.1	-5	
I _{OFF}	Off current	V _{CC} = 0V; V _I or V _O = 0 to 4.5V		0.1	±100	μA
I _{HOLD}	Bus Hold current A or B ports ⁶	V _{CC} = 3V; V _I = 0.8V	75	130	μA	
		V _{CC} = 3V; V _I = 2.0V	-75	-140		
		V _{CC} = 0V to 3.6V; V _{CC} = 3.6V	±500			
I _{EX}	Current into an output in the High state when V _O > V _{CC}	V _O = 5.5V; V _{CC} = 3.0V		50	125	μA
I _{PU/PD}	Power up/down 3-State output current ³	V _{CC} ≤ 1.2V; V _O = 0.5V to V _{CC} ; V _I = GND or V _{CC} ; OE/OE = Don't care		40	±100	μA
I _{CCH}	Quiescent supply current	V _{CC} = 3.6V; Outputs High, V _I = GND or V _{CC} , I _O = 0		0.07	0.1	mA
I _{CCL}		V _{CC} = 3.6V; Outputs Low, V _I = GND or V _{CC} , I _O = 0		3.2	5	
I _{CCZ}		V _{CC} = 3.6V; Outputs Disabled; V _I = GND or V _{CC} , I _O = 0 ⁵		0.07	0.1	
ΔI _{CC}	Additional supply current per input pin ²	V _{CC} = 3V to 3.6V; One input at V _{CC} -0.6V, Other inputs at V _{CC} or GND		0.2	0.4	mA

NOTES:

1. All typical values are at V_{CC} = 3.3V and T_{amb} = 25°C.
2. This is the increase in supply current for each input at the specified voltage level other than V_{CC} or GND
3. This parameter is valid for any V_{CC} between 0V and 1.2V with a transition time of up to 10msec. From V_{CC} = 1.2V to V_{CC} = 3.3V ± 0.3V a transition time of 100μsec is permitted. This parameter is valid for T_{amb} = 25°C only.
4. Unused pins at V_{CC} or GND.
5. I_{CCZ} is measured with outputs pulled up to V_{CC} or pulled down to ground.
6. This is the bus hold overdrive current required to force the input to the opposite logic state.

2.5V/3.3V 16-bit transceiver (3-State)

74ALVT16245

[查询 74ALVT16245DL-T 供应商](#)

AC CHARACTERISTICS (3.3V ± 0.3V RANGE)

GND = 0V; $t_R = t_F = 2.5\text{ns}$; $C_L = 50\text{pF}$; $R_L = 500\Omega$; $T_{\text{amb}} = -40^\circ\text{C}$ to $+85^\circ\text{C}$.

SYMBOL	PARAMETER	WAVEFORM	LIMITS			UNIT
			$V_{CC} = 3.3V \pm 0.3V$			
			MIN	TYP ¹	MAX	
t_{PLH} t_{PHL}	Propagation delay nAx to nBx or nBx to nAx	1	0.5 0.5	1.5 1.5	2.4 2.4	ns
t_{PZH} t_{PZL}	Output enable time to High and Low level	2	1.0 1.0	2.1 1.7	3.5 2.9	ns
t_{PHZ} t_{PLZ}	Output disable time from High and Low Level	2	1.5 1.5	3.4 2.8	4.5 3.7	ns

NOTE:

1. All typical values are at $V_{CC} = 3.3V$ and $T_{\text{amb}} = 25^\circ\text{C}$.

DC ELECTRICAL CHARACTERISTICS (2.5V ± 0.2V RANGE)

SYMBOL	PARAMETER	TEST CONDITIONS	LIMITS			UNIT
			Temp = -40°C to $+85^\circ\text{C}$			
			MIN	TYP ¹	MAX	
V_{IK}	Input clamp voltage	$V_{CC} = 2.3V$; $I_{IK} = -18\text{mA}$		-0.85	-1.2	V
V_{OH}	High-level output voltage	$V_{CC} = 2.3$ to $3.6V$; $I_{OH} = -100\mu\text{A}$ $V_{CC} = 2.3V$; $I_{OH} = -8\text{mA}$	$V_{CC}-0.2$ 1.8	2.1		V
V_{OL}	Low-level output voltage	$V_{CC} = 2.3V$; $I_{OL} = 100\mu\text{A}$ $V_{CC} = 2.3V$; $I_{OL} = 24\text{mA}$ $V_{CC} = 2.3V$; $I_{OL} = 8\text{mA}$		0.07 0.3	0.2 0.5	V
I_I	Input leakage current	$V_{CC} = 2.7V$; $V_I = V_{CC}$ or GND	Control pins	0.1	± 1	μA
		$V_{CC} = 0$ or $2.7V$; $V_I = 5.5V$		0.1	10	
		$V_{CC} = 2.7V$; $V_I = 5.5V$	Data pins ⁴	0.1	20	
		$V_{CC} = 2.7V$; $V_I = V_{CC}$		0.1	10	
		$V_{CC} = 2.7V$; $V_I = 0$		0.1	-5	
I_{OFF}	Off current	$V_{CC} = 0V$; V_I or $V_O = 0$ to $4.5V$		0.1	± 100	μA
I_{HOLD}	Bus Hold current	$V_{CC} = 2.3V$; $V_I = 0.7V$		90		μA
	Data inputs ⁶	$V_{CC} = 2.3V$; $V_I = 1.7V$		-10		
I_{EX}	Current into an output in the High state when $V_O > V_{CC}$	$V_O = 5.5V$; $V_{CC} = 2.3V$		50	125	μA
$I_{PU/PD}$	Power up/down 3-State output current ³	$V_{CC} \leq 1.2V$; $V_O = 0.5V$ to V_{CC} ; $V_I = \text{GND}$ or V_{CC} ; OE/OE = Don't care		40	100	μA
I_{CCH}	Quiescent supply current	$V_{CC} = 2.7V$; Outputs High, $V_I = \text{GND}$ or V_{CC} , $I_O = 0$		0.04	0.1	mA
I_{CCL}		$V_{CC} = 2.7V$; Outputs Low, $V_I = \text{GND}$ or V_{CC} , $I_O = 0$		2.3	45	
I_{CCZ}		$V_{CC} = 2.7V$; Outputs Disabled; $V_I = \text{GND}$ or V_{CC} , $I_O = 0^5$		0.04	0.1	
ΔI_{CC}	Additional supply current per input pin ²	$V_{CC} = 2.3V$ to $2.7V$; One input at $V_{CC}-0.6V$, Other inputs at V_{CC} or GND		0.1	0.4	mA

NOTES:

1. All typical values are at $V_{CC} = 2.5V$ and $T_{\text{amb}} = 25^\circ\text{C}$.
2. This is the increase in supply current for each input at the specified voltage level other than V_{CC} or GND
3. This parameter is valid for any V_{CC} between 0V and 1.2V with a transition time of up to 10msec. From $V_{CC} = 1.2V$ to $V_{CC} = 2.5V \pm 0.3V$ a transition time of 100 μsec is permitted. This parameter is valid for $T_{\text{amb}} = 25^\circ\text{C}$ only.
4. Unused pins at V_{CC} or GND.
5. I_{CCZ} is measured with outputs pulled up to V_{CC} or pulled down to ground.
6. Not guaranteed.

2.5V/3.3V 16-bit transceiver (3-State)

74ALVT16245

[查询 74ALVT16245DL-T 供应商](#)

DYNAMIC SWITCHING THRESHOLD

Dynamic switching threshold is the change in V_{IH} and V_{IL} when the device is operated in various switching and output loading conditions. The cause of this variation is due to extra load placed on internal circuit structures. V_{IHD} and V_{ILD} are measures of the dynamic switching threshold. V_{IHD} is the input high switching level when the device is heavily loaded. V_{ILD} is the input low switching level when the device is heavily loaded.

V_{ILD}/V_{IHD} vs V_{CC}

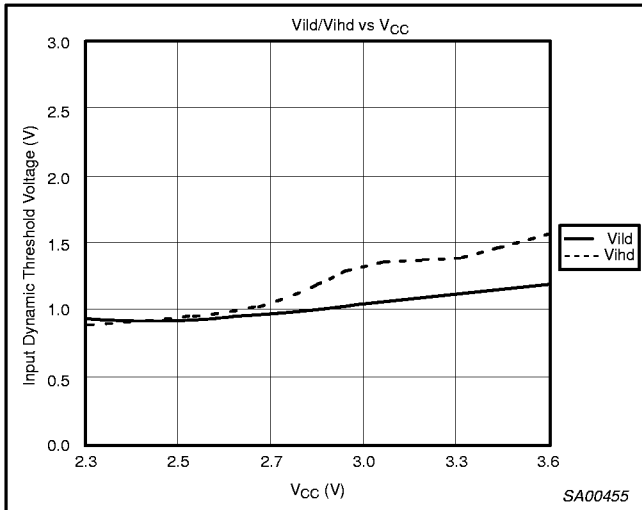

V_{ILD}/V_{IHD} vs Frequency

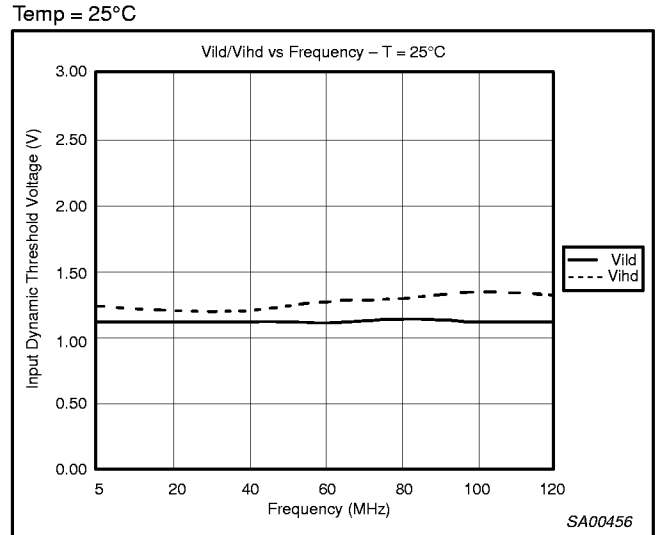

GROUND/ V_{CC} BOUNCE

V_{OLP} vs Temperature

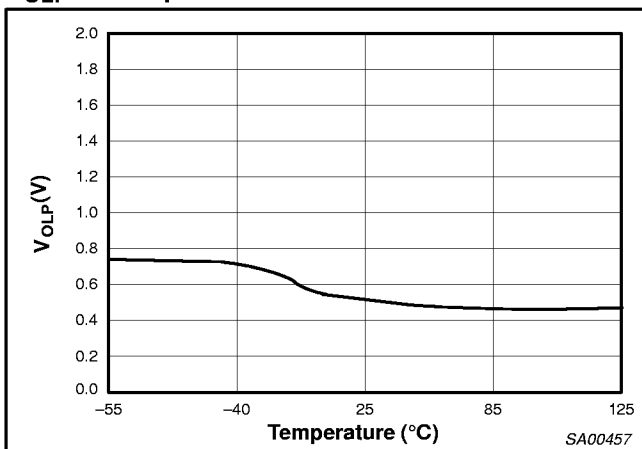

V_{OLP} vs Capacitive Load

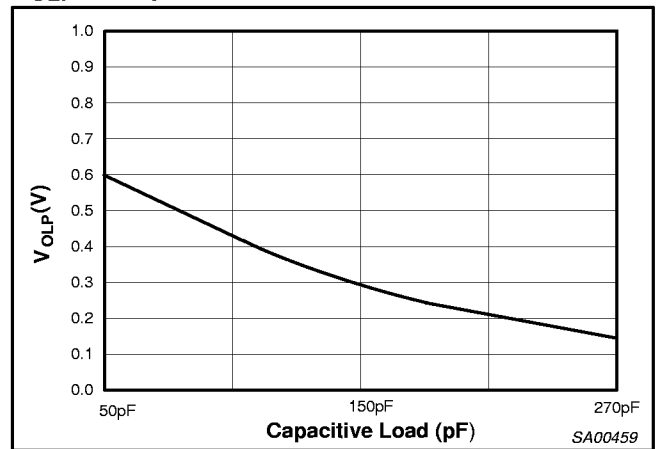

V_{OHV} vs Temperature

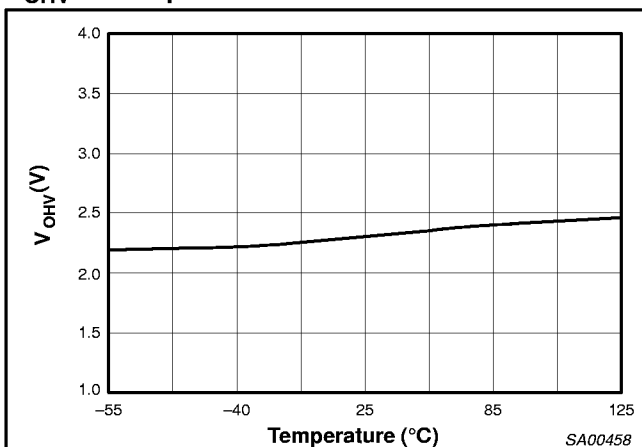

V_{OHV} vs Capacitive Load

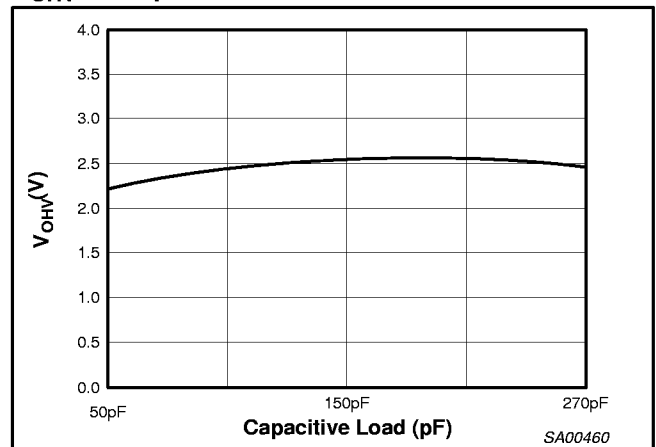

2.5V/3.3V 16-bit transceiver (3-State)

74ALVT16245

[查询 74ALVT16245DL-T 供应商](#)

AC CHARACTERISTICS (2.5V ± 0.2V RANGE)

GND = 0V; $t_R = t_F = 2.5\text{ns}$; $C_L = 50\text{pF}$; $R_L = 500\Omega$; $T_{\text{amb}} = -40^\circ\text{C}$ to $+85^\circ\text{C}$.

SYMBOL	PARAMETER	WAVEFORM	LIMITS			UNIT
			$V_{CC} = 2.5V \pm 0.2V$			
			MIN	TYP ¹	MAX	
t_{PLH} t_{PHL}	Propagation delay nAx to nBx or nBx to nAx	1	0.5 0.5	1.7 1.9	2.8 2.8	ns
t_{PZH} t_{PZL}	Output enable time to High and Low level	2	1.5 1.0	3.0 2.3	4.5 3.5	ns
t_{PHZ} t_{PLZ}	Output disable time from High and Low Level	2	1.5 1.0	3.0 2.3	4.6 3.5	ns

NOTE:

1. All typical values are at $V_{CC} = 2.5V$ and $T_{\text{amb}} = 25^\circ\text{C}$.

SKEW DATA

t_{ps} (Pin Skew or Transition Skew)

$$t_{ps} = |t_{PHL} - t_{PLH}|$$

t_{ps} Max	$V_{CC} = 2.3$	$V_{CC} = 2.5$	$V_{CC} = 2.7$	$V_{CC} = 3.0$	$V_{CC} = 3.3$	$V_{CC} = 3.6$	UNITS
	429	469	430	426	267	336	ps

$$t_{OST} = |t_{\Phi m} - t_{\Phi n}|$$

Where Φ is any edge transition (high-to-low or low-to-high) measured between any two outputs (m or n) within any given device.

t_{OST} nAn-nBn	$V_{CC} = 2.3$	$V_{CC} = 2.5$	$V_{CC} = 2.7$	$V_{CC} = 3.0$	$V_{CC} = 3.3$	$V_{CC} = 3.6$	UNITS
	546	625	586	546	427	397	ps
nBn-nAn	508	547	586	506	427	417	

NOTE:

One output switching, Temp = 25°C .

t_{OSHL} , t_{OSLH} : (Common Edge Skew)

$$t_{OSHL} = |t_{PHL\text{ max}} - t_{PHL\text{ min}}| \text{ (Output Skew for Low-to-High Transitions)}$$

$$t_{OSLH} = |t_{PLH\text{ max}} - t_{PLH\text{ min}}| \text{ (Output Skew for High-to-Low Transitions)}$$

t_{OSLH} nAn-nBn	$V_{CC} = 2.3$	$V_{CC} = 2.5$	$V_{CC} = 2.7$	$V_{CC} = 3.0$	$V_{CC} = 3.3$	$V_{CC} = 3.6$	UNITS
	312	312	313	276	267	257	
t_{OSHL} nAn-nBn	312	352	352	297	289	267	
t_{OSLH} nBn-nAn	235	273	312	274	296	326	
t_{OSHL} nBn-nAn	234	235	274	248	287	267	

NOTE:

One output switching, Temp = 25°C .

2.5V/3.3V 16-bit transceiver (3-State)

[查询 74ALVT16245DL-T 供应商](#)

74ALVT16245

EXTENDED DATA

TPHL vs TEMP

V_{CC} = 3.3V, one output switching

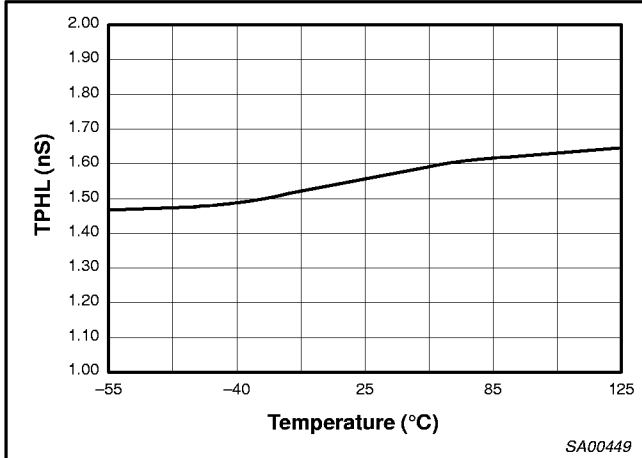

TPHL vs NUMBER of OUTPUTS SWITCHING

T = 25°C, 50pF/500 ohm load

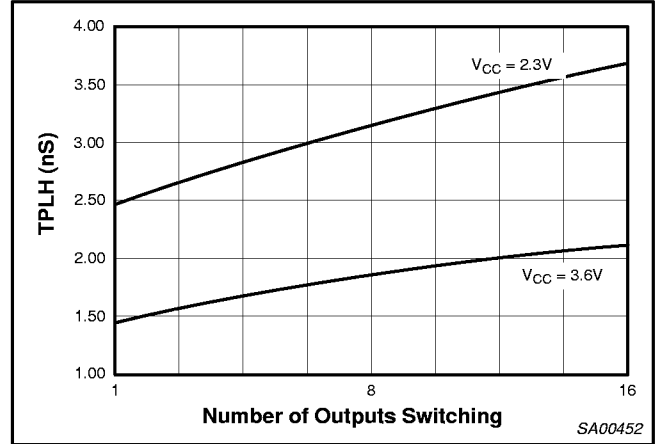

TPHL vs TEMP

V_{CC} = 3.3V, one output switching

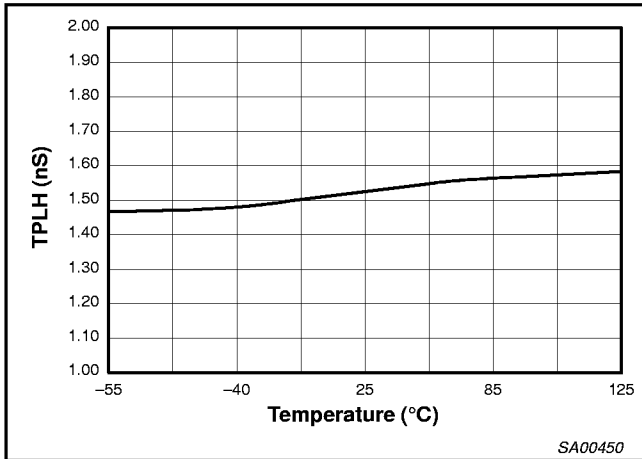

TPHL vs NUMBER of OUTPUTS SWITCHING

T = 25°C, 50pF/500 ohm load

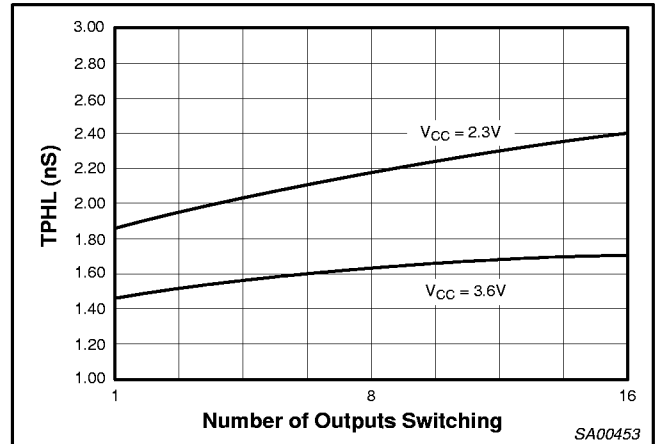

TPHL vs OUTPUT LOAD

Outputs also loaded with 500 ohms to ground, T = 25°C

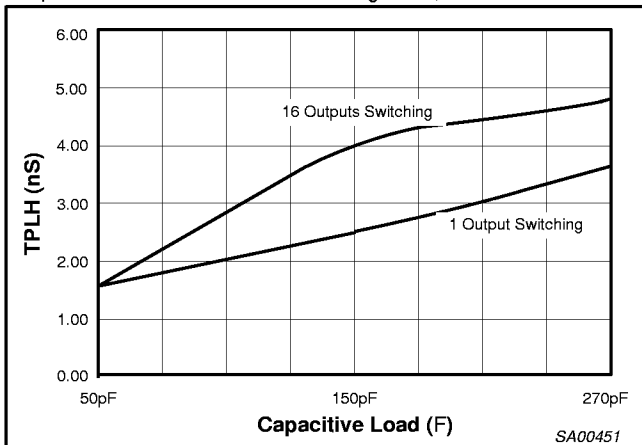

TPHL vs OUTPUT LOAD

Outputs also loaded with 500 ohms to ground, T = 25°C

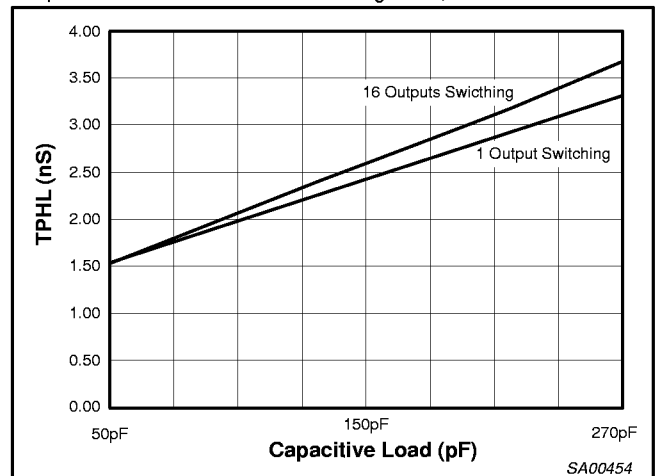

2.5V/3.3V 16-bit transceiver (3-State)

[查询 74ALVT16245DL-T 供应商](#)

74ALVT16245

AC WAVEFORMS

$V_M = 1.5V$ at $V_{CC} \geq 3.0V$, $V_M = V_{CC}/2$ at $V_{CC} \leq 2.7V$
 $V_X = V_{OL} + 0.3V$ at $V_{CC} \geq 3.0V$, $V_X = V_{OL} + 0.15V$ at $V_{CC} \leq 2.7V$
 $V_Y = V_{OH} - 0.3V$ at $V_{CC} \geq 3.0V$, $V_Y = V_{OH} - 0.15V$ at $V_{CC} \leq 2.7V$

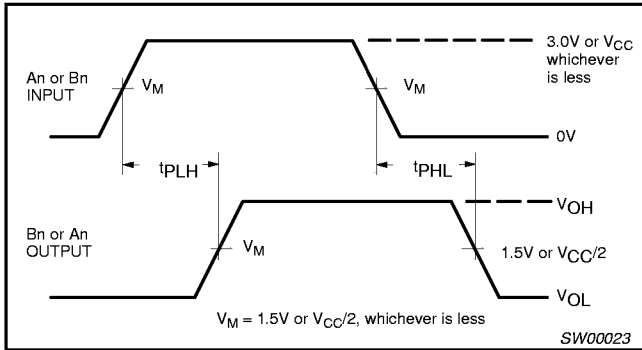

Waveform 1. Input to Output Propagation Delays

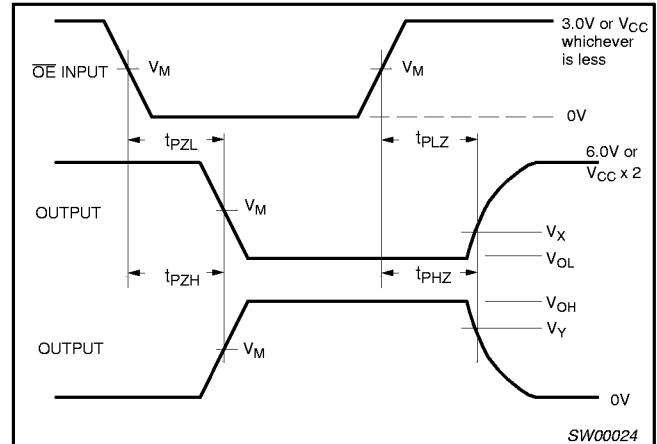

Waveform 2. 3-State Output Enable and Disable Times

TEST CIRCUIT AND WAVEFORMS

Test Circuit for 3-State Outputs

SWITCH POSITION

TEST	SWITCH
t_{PLZ}/t_{PZL}	6V or $V_{CC} \times 2$
t_{PLH}/t_{PHL}	Open
t_{PHZ}/t_{PZH}	GND

DEFINITIONS

R_L = Load resistor; see AC CHARACTERISTICS for value.
 C_L = Load capacitance includes jig and probe capacitance: See AC CHARACTERISTICS for value.
 R_T = Termination resistance should be equal to Z_{OUT} of pulse generators.

FAMILY	INPUT PULSE REQUIREMENTS				
	Amplitude	Rep. Rate	t_w	t_R	t_F
74ALVT16	3.0V or V_{CC} whichever is less	$\leq 10\text{MHz}$	500ns	$\leq 2.5\text{ns}$	$\leq 2.5\text{ns}$

SW00025

2.5V/3.3V ALVT 16-bit transceiver (3-State)

74ALVT16245

[查询 74ALVT16245DL-T 供应商](#)

SSOP48: plastic shrink small outline package; 48 leads; body width 7.5mm

SOT370-1

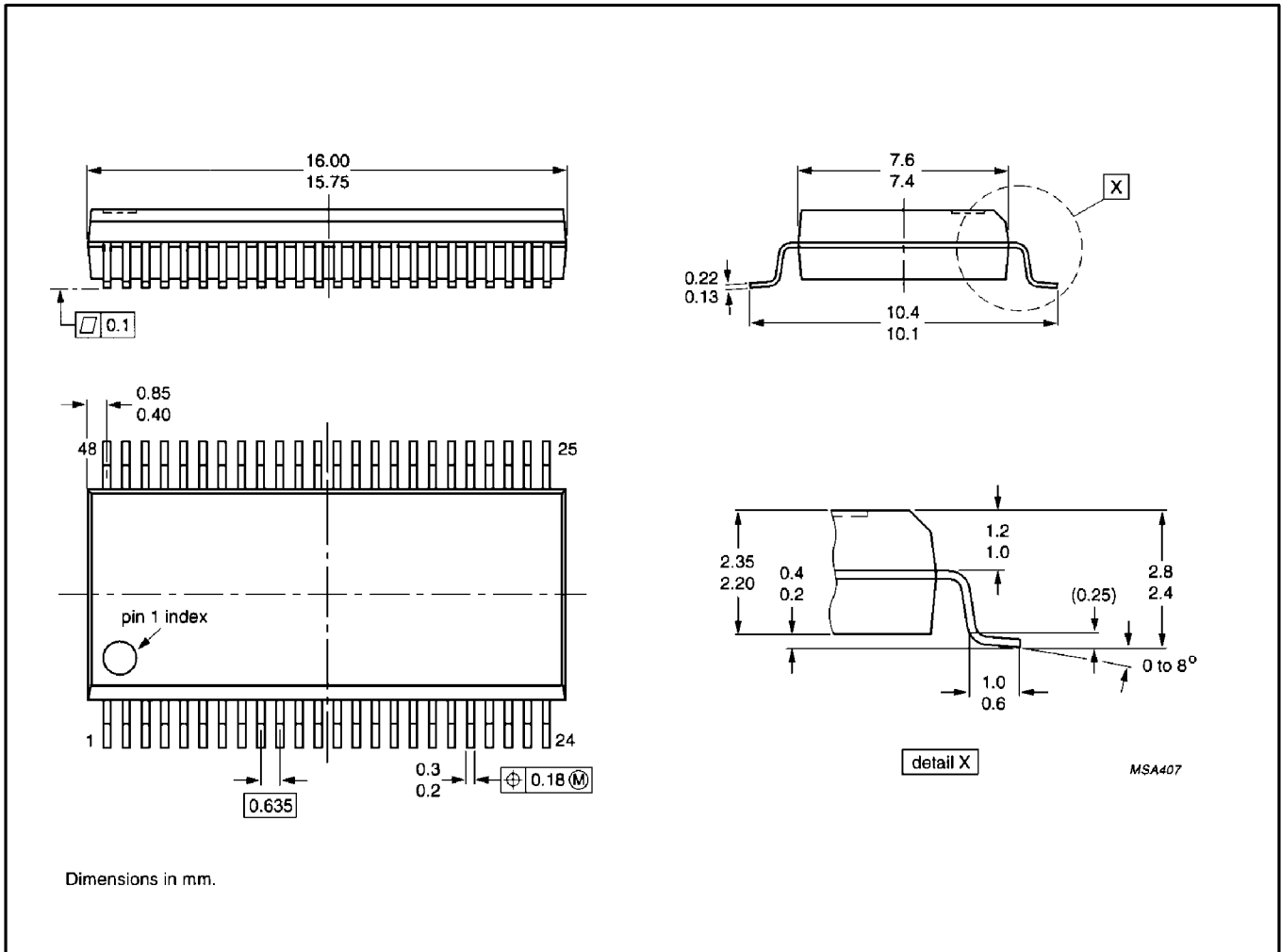

2.5V/3.3V ALVT 16-bit transceiver (3-State)

74ALVT16245

[查询 74ALVT16245DL-T 供应商](#)

TSSOP48: plastic thin shrink small outline package; 48 leads; body width 6.1mm

SOT362-1

