

**TG39**  
**MIL-C-26482 Series I and II, MIL-C-83723 Series I,**  
**and NAS 1599 Connector Wrench**

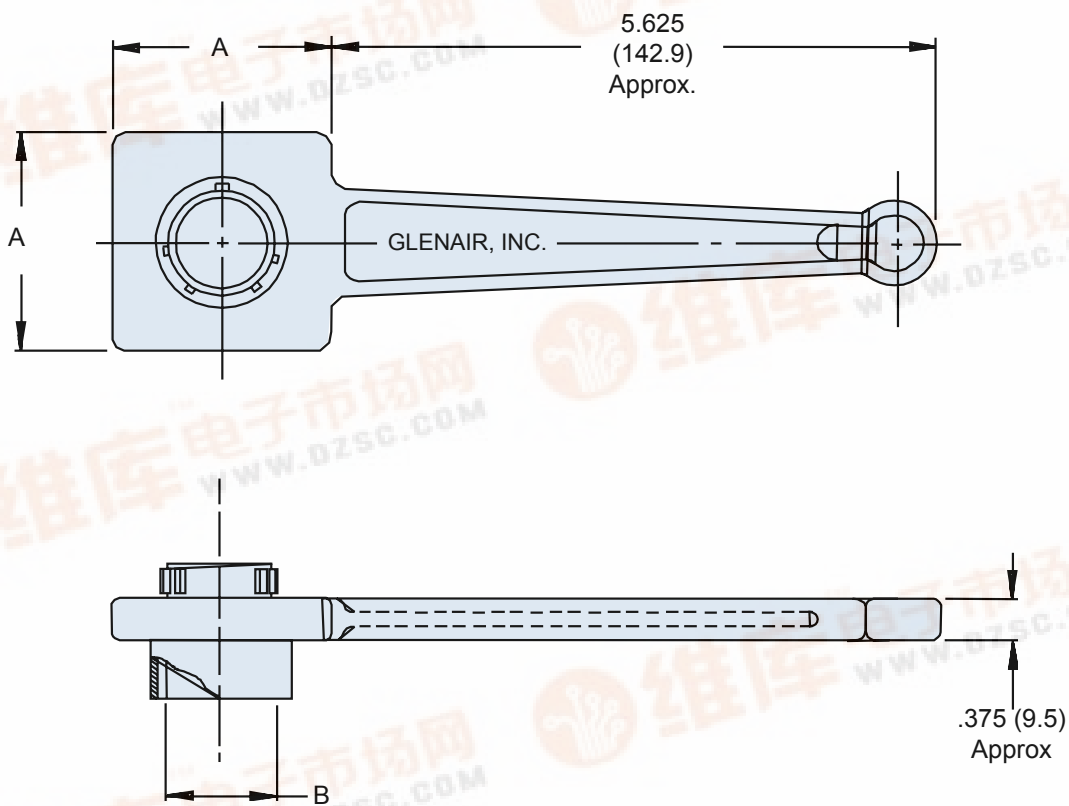

Torque

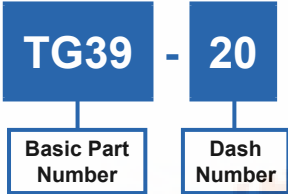

Shell Size	A Dim. ± .062 (1.6)	B Dia. Ref.
8	1.250 (31.8)	.362 (9.2)
10	1.250 (31.8)	.490 (12.4)
12	1.250 (31.8)	.607 (15.4)
14	1.250 (31.8)	.732 (18.6)
16	2.000 (50.8)	.857 (21.8)
18	2.000 (50.8)	.962 (24.4)
20	2.000 (50.8)	1.087 (27.6)
22	2.000 (50.8)	1.212 (30.8)
24	2.000 (50.8)	1.337 (34.0)

**APPLICATION NOTES**

1. Metric dimensions (mm) are indicated in parentheses.
2. Material: Aluminum alloy with electroless nickel finish.



**This datasheet has been downloaded from:**

**[www.EEworld.com.cn](http://www.EEworld.com.cn)**

**Free Download**

**Daily Updated Database**

**100% Free Datasheet Search Site**

**100% Free IC Replacement Search Site**

**Convenient Electronic Dictionary**

**Fast Search System**

**[www.EEworld.com.cn](http://www.EEworld.com.cn)**