

- 1N3016BUR-1 thru 1N3045BUR-1 AVAILABLE IN JAN, JANTX AND JANTXV PER MIL-PRF-19500/115
- 1 WATT ZENER DIODES 供应商
- LEADLESS PACKAGE FOR SURFACE MOUNT
- DOUBLE PLUG CONSTRUCTION
- METALLURGICALLY BONDED

1N3016BUR-1
thru
1N3045BUR-1
and
CDLL3016B
thru
CDLL3045B

MAXIMUM RATINGS

Operating Temperature: -65°C to +175°C
Storage Temperature: -65°C to +175°C
DC Power Dissipation: 1watt @ $T_{EC} = +125^{\circ}C$
Power Derating: 20 mW / °C above $T_{EC} = +125^{\circ}C$
Forward Voltage @ 200mA: 1.2 volts maximum

ELECTRICAL CHARACTERISTICS @ 25°C

CDI TYPE NUMBER (NOTE 1)	NOMINAL ZENER VOLTAGE $V_Z @ 1Z_T$ (NOTE 2)	ZENER TEST CURRENT $1Z_T$ mA	MAXIMUM ZENER IMPEDANCE (NOTE 3)			MAX. DC ZENER CURRENT $1Z_M$ mA	MAX. REVERSE LEAKAGE CURRENT $I_R @ V_R$	
			$Z_{ZT} @ 1Z_T$		VOLTS		μA	VOLTS
			OHMS	OHMS				
CDLL3016B	6.8	37	3.5	700	1.0	140	5.0	5.2
CDLL3017B	7.5	34	4.0	700	.5	125	5.0	5.7
CDLL3018B	8.2	31	4.5	700	.5	115	5.0	6.2
CDLL3019B	9.1	28	5	700	.5	105	5.0	6.9
CDLL3020B	10	25	7	700	.25	95	5.0	7.6
CDLL3021B	11	23	8	700	.25	85	1.0	8.4
CDLL3022B	12	21	9	700	.25	80	1.0	9.1
CDLL3023B	13	19	10	700	.25	74	0.5	9.9
CDLL3024B	15	17	14	700	.25	63	0.5	11.4
CDLL3025B	16	15.5	16	700	.25	60	0.5	12.2
CDLL3026B	18	14	20	750	.25	52	0.5	13.7
CDLL3027B	20	12.5	22	750	.25	47	0.5	15.2
CDLL3028B	22	11.5	23	750	.25	43	0.5	16.7
CDLL3029B	24	10.5	25	750	.25	40	0.5	18.2
CDLL3030B	27	9.5	35	750	.25	34	0.5	20.6
CDLL3031B	30	8.5	40	1000	.25	31	0.5	22.8
CDLL3032B	33	7.5	45	1000	.25	28	0.5	25.1
CDLL3033B	36	7.0	50	1000	.25	26	0.5	27.4
CDLL3034B	39	6.5	60	1000	.25	23	0.5	29.7
CDLL3035B	43	6.0	70	1500	.25	21	0.5	32.7
CDLL3036B	47	5.5	80	1500	.25	19	0.5	35.8
CDLL3037B	51	5.0	95	1500	.25	18	0.5	38.8
CDLL3038B	56	4.5	110	2000	.25	17	0.5	42.6
CDLL3039B	62	4.0	125	2000	.25	15	0.5	47.1
CDLL3040B	68	3.7	150	2000	.25	14	0.5	51.7
CDLL3041B	75	3.3	175	2000	.25	12	0.5	56.0
CDLL3042B	82	3.0	200	3000	.25	11	0.5	62.2
CDLL3043B	91	2.8	250	3000	.25	10	0.5	69.2
CDLL3044B	100	2.5	350	3000	.25	9.0	0.5	76.0
CDLL3045B	110	2.3	450	4000	.25	8.3	0.5	83.6

- NOTE 1** No suffix signifies $\pm 20\%$. "A" Suffix signifies $\pm 10\%$, "B" Suffix signifies $\pm 5\%$. "C" suffix signifies $\pm 2\%$ and "B" suffix signifies $\pm 1\%$.
- NOTE 2** Zener voltage is measured with the device junction in thermal equilibrium at an ambient temperature of $25^{\circ}C \pm 3^{\circ}C$.
- NOTE 3** Zener impedance is derived by superimposing on $1Z_T$ A 60Hz rms a.c. current equal to 10% of $1Z_T$

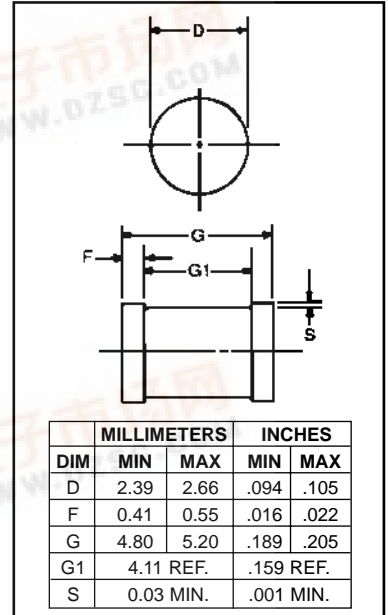

FIGURE 1

DESIGN DATA

CASE: DO-213AB, Hermetically sealed glass case. (MELF, LL41)

LEAD FINISH: Tin / Lead

THERMAL RESISTANCE: ($R_{\theta JEC}$): 50 $^{\circ}C/W$ maximum at $L = 0$ inch

THERMAL IMPEDANCE: ($Z_{\theta JX}$): 15 $^{\circ}C/W$ maximum

POLARITY: Diode to be operated with the banded (cathode) end positive with respect to the opposite end.

MOUNTING SURFACE SELECTION:
The Axial Coefficient of Expansion (COE) Of this Device is Approximately +6PPM/ $^{\circ}C$. The COE of the Mounting Surface System Should Be Selected To Provide A Suitable Match With This Device.



COMPENSATED DEVICES INCORPORATED

22 COREY STREET, MELROSE, MASSACHUSETTS 02176
PHONE (781) 665-1071 FAX (781) 665-7379
WEBSITE: <http://www.cdi-diodes.com> E-mail: mail@cdi-diodes.com



1N3016UR-1 thru 1N3045UR-1

[查询"1N3040BUR-1"供应商](#)

and

CDLL3016 thru CDLL3045B

FIGURE 2

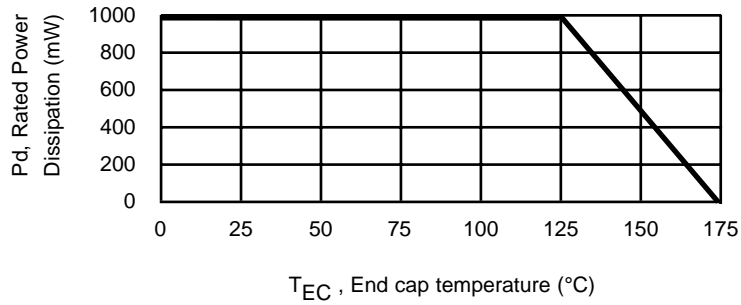

POWER DERATING CURVE

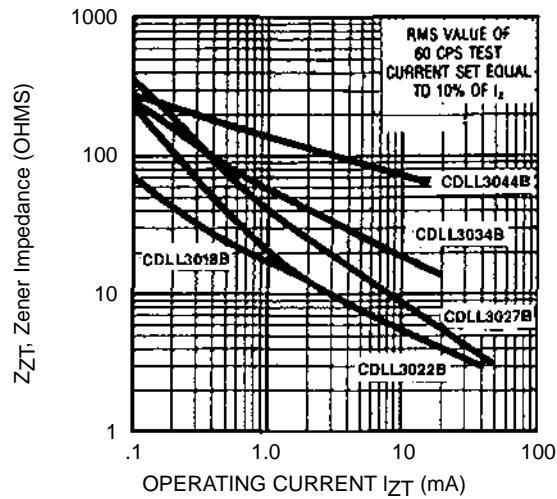

FIGURE 3

ZENER IMPEDANCE VS. OPERATING CURRENT