

查询"1591TFLBK"供应商

NOTES

- MATERIAL** (ABS) FLAME RETARDANT UL94 VO MATERIAL WITH BRASS INSERTS IN CORNER POSTS.
(STYRENE) IS NON-FLAME RETARDANT WITHOUT BRASS INSERTS.
- PARTS** (ABS) VERSION MACHINE SCREWS M3-0.5 x 10mm.
REPLACEMENT PN 1591MS100 (100 / BAG). (STYRENE) VERSION SELF TAPPING #4 x 0.5".
REPLACEMENT PN 1599TS100BK (100 / BAG).
- COLORS** (ABS) BLACK, GRAY, BLUE, & BEIGE, (STYRENE) BLACK ONLY.

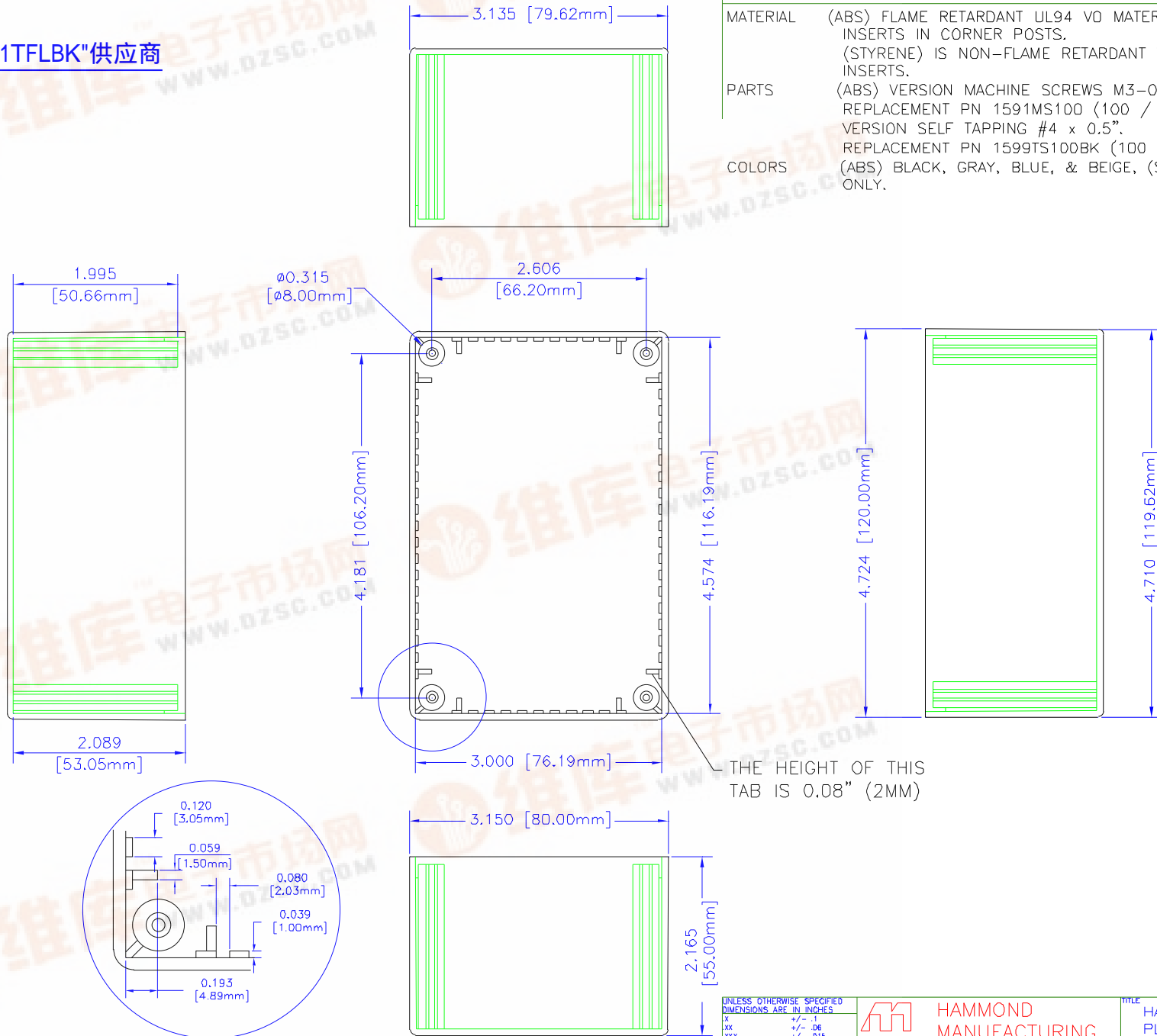

BOX

UNLESS OTHERWISE SPECIFIED
DIMENSIONS ARE IN INCHES
X +/- .1
XX +/- .06
XXX +/- .015
SLOTS +/- .009
ANGLES +/- .5 DEG

NOTICE
HAMMOND CLAIMS PROPRIETARY RIGHTS TO THE MATERIAL ON THIS DRAWING. IT IS INTENDED TO BE USED AS A REFERENCE FOR ENGINEERING INFORMATION ONLY. THIS INFORMATION MAY NOT BE USED TO MANUFACTURE PRODUCT WITHOUT WRITTEN PERMISSION FROM HAMMOND MANUFACTURING.



HAMMOND
MANUFACTURING

WEB: WWW.HAMMONDMFG.COM

TITLE
HAMMOND 1591 SERIES
PLASTIC ENCLOSURE

| | | | |
|-------------|---------|------|----------|
| DRAWN BY | MJM | DATE | 01/25/01 |
| SCALE | | PAGE | 1 OF 2 |
| PART NUMBER | 1591TFL | | |



查询"1591TFLBK"供应商

NOTES

MATERIAL (ABS) FLAME RETARDANT UL94 V0 MATERIAL WITH BRASS INSERTS IN CORNER POSTS.
(STYRENE) IS NON-FLAME RETARDANT WITHOUT BRASS INSERTS.

PARTS (ABS) VERSION MACHINE SCREWS M3-0.5 x 10mm.
REPLACEMENT PN 1591MS100 (100 / BAG). (STYRENE) VERSION SELF TAPPING #4 x 0.5".
REPLACEMENT PN 1599TS100BK (100 / BAG).

COLORS (ABS) BLACK, GRAY, BLUE, & BEIGE, (STYRENE) BLACK ONLY.

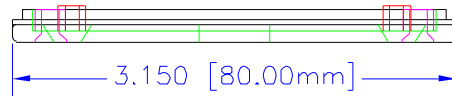
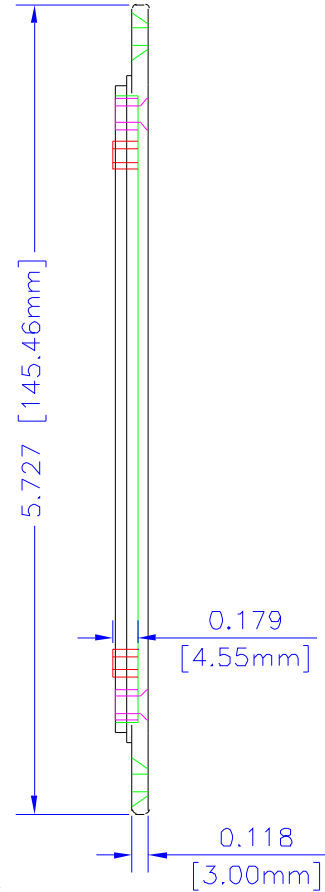
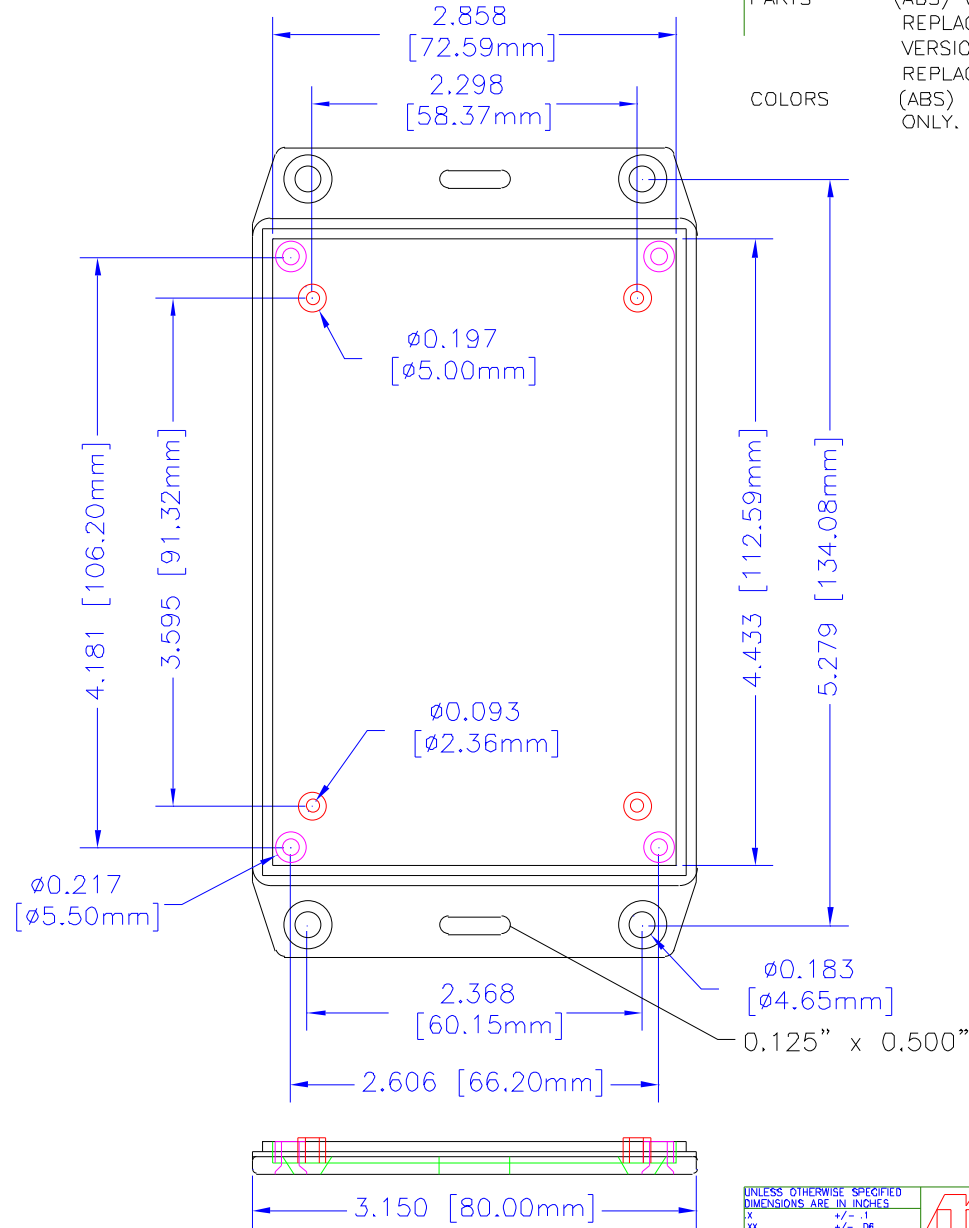
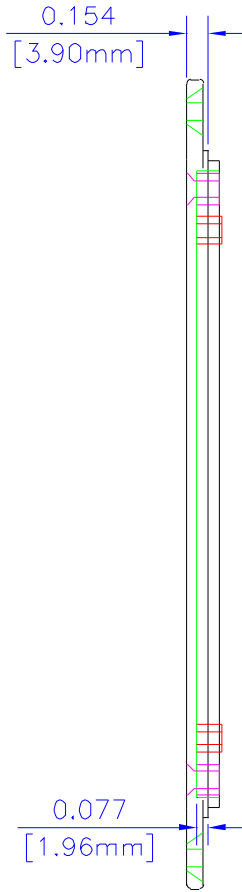

LID

UNLESS OTHERWISE SPECIFIED
DIMENSIONS ARE IN INCHES

XX +/- .1

XXX +/- .06

XXX +/- .015

CUPS +/- .005

ANGLES +/- .5 DEG

NOTICE
HAMMOND MANUFACTURING PROPRIETARY RIGHTS TO THE MATERIAL ON THIS DRAWING. IT IS INTENDED TO BE USED AS A REFERENCE FOR ENGINEERING INFORMATION ONLY. THIS INFORMATION MAY NOT BE USED TO MANUFACTURE PRODUCTS WITHOUT WRITTEN PERMISSION FROM HAMMOND MANUFACTURING.



HAMMOND
MANUFACTURING

WEB: WWW.HAMMONDMFG.COM

TITLE
HAMMOND 1591 SERIES
PLASTIC ENCLOSURE

DRAWN BY MJM DATE 01/25/01

SCALE PAGE 2 OF 2

PART NUMBER
1591TFL