

Pb Free

RoHS Compliant

Features

- Crystal unit for audio-visual, office equipment
- Ultra-miniature and low profile (2.5x2.0x0.45mm)
- Ceramic package
- A lead free product
- Reflow compatible

Applications

- Digital Electronics
- Audio-Visual, Office Equipment

How to Order

CX2520SB 27000 D0 P E S ZZ
 ① ② ③ ④ ⑤ ⑥ ⑦

① Code

② Typical Frequencies

Code	Freq.(kHz)	Code	Freq.(kHz)
13560	13560.000	30000	30000.000
16000	16000.000	32000	32000.000
18000	18000.000	33000	33000.000
20000	20000.000	33333	33333.000
24000	24000.000	40000	40000.000
26000	26000.000	48000	48000.000
27000	27000.000	54000	54000.000
27120	27120.000		

*Please inquire about frequencies other than the above.

③ Load Capacitance

D0	8pF
-----------	-----

④ Frequency Stability

P	$\pm 50 \times 10^{-6}$
----------	-------------------------

⑤ Operating Temperature Range

E	-10°C to +70°C
----------	----------------

⑥ Frequency Temperature Stability

S	$\pm 50 \times 10^{-6}$
----------	-------------------------

⑦ Special

ZZ	Custom Specification
-----------	----------------------

Specifications

Items	Symbol	Specification	Units	Remarks
Frequency Range	f _{nom}	13560 to 60000	kHz	
Overtone Order	OT	Fundamental	—	
Frequency Tolerance	f _{tol}	±50	×10 ⁻⁶	@ 25°C
Frequency Temp. Characteristics	f _{tem}	±50	×10 ⁻⁶	ref.@ 25°C Over Operating Temp. Range
Motional Series Resistance	R1	Table 1	ohm	
Level of Drive	DL	Table 2	μW	
Load Capacitance	CL	8	pF	
Operating Temp. Range	T _{use}	-10 to +70	°C	
Storage Temp. Range	T _{stg}	-40 to +85	°C	

* Please inquire about specifications other than the above.

Table1 Motional Series Resistances

Frequency Range	Motional Series Resistance	Units
13560 to 15999kHz	300	ohm
16000 to 19999kHz	150	
20000 to 39999kHz	100	
40000 to 60000kHz	50	

Table2 Level of Drive

Frequency Range	Level of Drive	Units
13560 to 60000kHz	10 (100 max.)	μW

Dimensions

(Unit : mm)

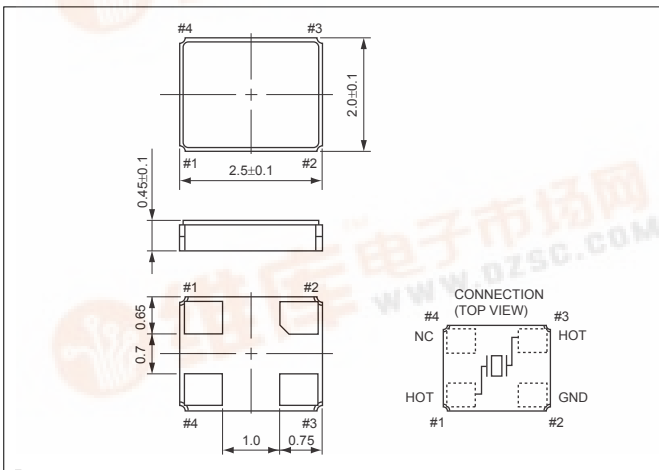

Recommended Land Pattern

(Unit : mm)

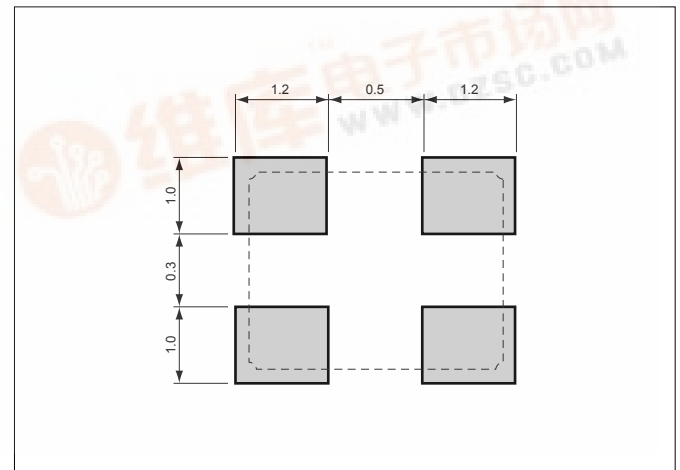

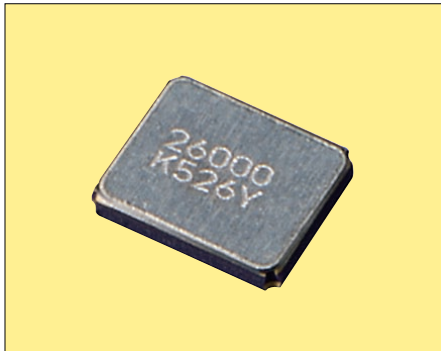

Pb Free **RoHS Compliant**

Features

- Reference frequency for telecommunication systems
- Reflow compatible
- Using ceramic package resulting in high reliability
- Small and low profile

Applications

- Mobile Communications, Bluetooth, Wireless LAN

How to Order

CX2520SB 32000 D0 F L J ZZ
 ① ② ③ ④ ⑤ ⑥ ⑦

- ① Code
- ② Typical Frequencies

Code	Freq.(kHz)	Code	Freq.(kHz)
13560	13560.000	27120	27120.000
16000	16000.000	32000	32000.000
18000	18000.000	38400	38400.000
19200	19200.000	40000	40000.000
24000	24000.000	44000	44000.000
26000	26000.000		

*Please inquire about frequencies other than the above.

- ③ Load Capacitance

D0	8pF
----	-----
- ④ Frequency Stability

F	$\pm 10 \times 10^{-6}$
---	-------------------------
- ⑤ Operating Temperature Range

L	-30°C to +85°C
---	----------------
- ⑥ Frequency Temperature Stability

J	$\pm 15 \times 10^{-6}$
---	-------------------------
- ⑦ Special

ZZ	Custom Specification
----	----------------------

Specifications

Items	Symbol	Specification	Units	Remarks
Frequency Range	f _{nom}	13560 to 60000	kHz	
Overtone Order	OT	Fundamental	—	
Frequency Tolerance	f _{tol}	± 10	$\times 10^{-6}$	@ 25°C
Frequency Temp. Characteristics	f _{tem}	± 15	$\times 10^{-6}$	ref.@ 25°C Over Operating Temp. Range
Motional Series Resistance	R1	Table 1	ohm	
Level of Drive	DL	Table 2	μW	
Load Capacitance	CL	8	pF	
Operating Temp. Range	T _{use}	-30 to +85	°C	
Storage Temp. Range	T _{stg}	-40 to +85	°C	

* Please inquire about specifications other than the above.

Table1 Motional Series Resistances

Frequency Range	Motional Series Resistance	Units
13560 to 15999kHz	300	ohm
16000 to 19999kHz	150	
20000 to 39999kHz	100	
40000 to 60000kHz	50	

Table2 Level of Drive

Frequency Range	Level of Drive	Units
13560 to 60000kHz	10 (100 max.)	μW

Dimensions

(Unit : mm)

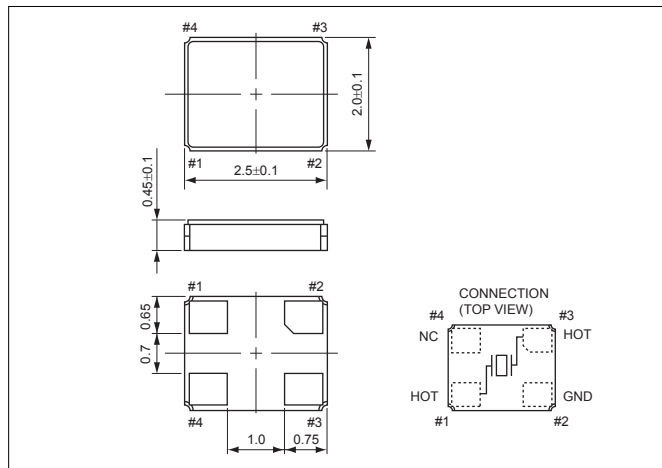

Recommended Land Pattern

(Unit : mm)

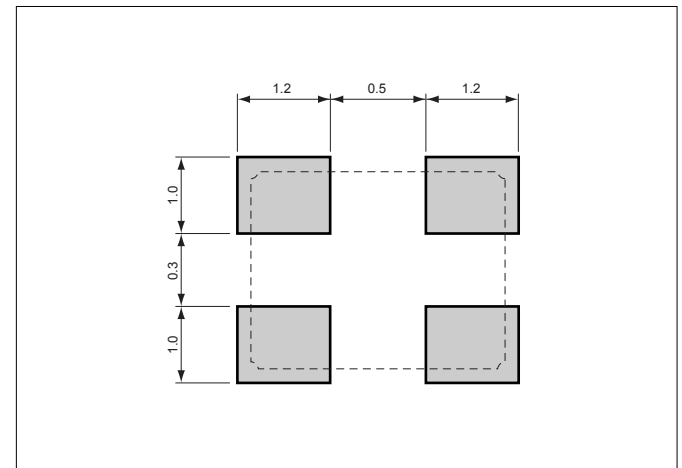



Pb Free

RoHS Compliant

Features

- Crystal unit for audio-visual, office equipment
- Miniature and low profile (3.2x2.5x0.55mm)
- Ceramic package
- A lead free product
- Reflow compatible

Applications

- Digital Electronics
- Audio-Visual, Office Equipment

How to Order

CX3225SB 24000 D0 P E S ZZ
 ① ② ③ ④ ⑤ ⑥ ⑦

- ① Code
- ② Typical Frequencies

Code	Freq.(kHz)	Code	Freq.(kHz)
12000	12000.000	25000	25000.000
13560	13560.000	26000	26000.000
14318	14318.180	27000	27000.000
14745	14745.600	27120	27120.000
16000	16000.000	30000	30000.000
18432	18432.000	33000	33000.000
20000	20000.000	33333	33333.000
22579	22579.000	40000	40000.000
24000	24000.000	48000	48000.000
24576	24576.000	54000	54000.000

*Please inquire about frequencies other than the above.

③ Load Capacitance

D0	8pF
-----------	-----

④ Frequency Stability

P	$\pm 50 \times 10^{-6}$
----------	-------------------------

⑤ Operating Temperature Range

E	-10°C to +70°C
----------	----------------

⑥ Frequency Temperature Stability

S	$\pm 50 \times 10^{-6}$
----------	-------------------------

⑦ Special

ZZ	Custom Specification
-----------	----------------------

Specifications

Items	Symbol	Specification	Units	Remarks
Frequency Range	f _{nom}	12000 to 54000	kHz	
Overtone Order	OT	Fundamental	—	
Frequency Tolerance	f _{tol}	±50	×10 ⁻⁶	@ 25°C
Frequency Temp. Characteristics	f _{tem}	±50	×10 ⁻⁶	ref.@ 25°C Over Operating Temp. Range
Motional Series Resistance	R1	Table 1	ohm	
Level of Drive	DL	Table 2	μW	
Load Capacitance	CL	8	pF	
Operating Temp. Range	T _{use}	-10 to +70	°C	
Storage Temp. Range	T _{stg}	-40 to +85	°C	

*Please inquire about specifications other than the above.

Table1 Motional Series Resistances

Frequency Range	Motional Series Resistance	Units
12000 to 13999kHz	300	ohm
14000 to 15999kHz	200	
16000 to 26999kHz	100	
27000 to 54000kHz	50	

Table2 Level of Drive

Frequency Range	Level of Drive	Units
12000 to 54000kHz	10 (100 max.)	μW

Dimensions

(Unit : mm)

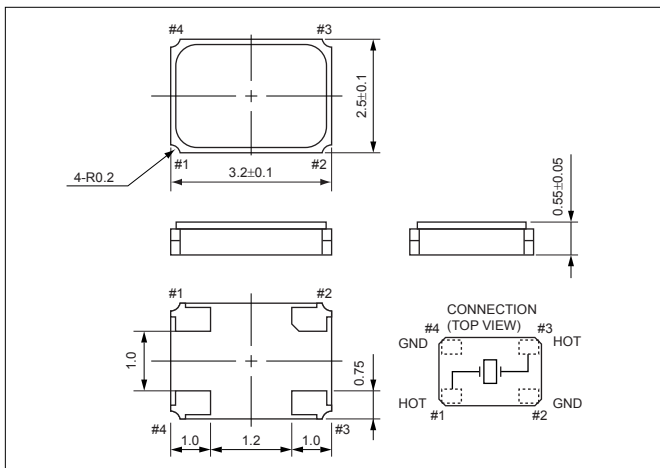

Recommended Land Pattern

(Unit : mm)

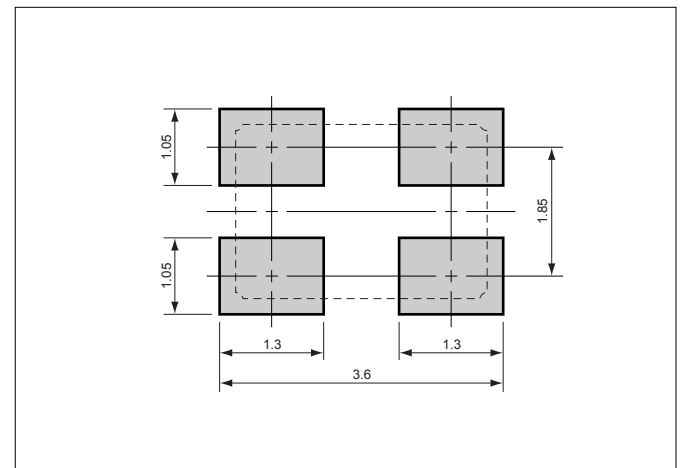



Pb Free

RoHS Compliant

Features

- Reference frequency for telecommunication systems
- Reflow compatible
- Using ceramic package resulting in high reliability
- Small and low profile

Applications

- Mobile Communications, Bluetooth, Wireless LAN

How to Order

CX3225SB 26000 D0 F L J ZZ
 ① ② ③ ④ ⑤ ⑥ ⑦

- ① Code
- ② Typical Frequencies

Code	Freq.(kHz)	Code	Freq.(kHz)
12000	12000.000	20000	20000.000
13000	13000.000	26000	26000.000
13560	13560.000	32000	32000.000
16000	16000.000	38400	38400.000
19200	19200.000	40000	40000.000

*Please inquire about frequencies other than the above.

③ Load Capacitance	D0 8pF
④ Frequency Stability	F ±10×10 ⁻⁶
⑤ Operating Temperature Range	L -30°C to +85°C
⑥ Frequency Temperature Stability	J ±15×10 ⁻⁶
⑦ Special	ZZ Custom Specification

Specifications

Items	Symbol	Specification	Units	Remarks
Frequency Range	f _{nom}	12000 to 54000	kHz	
Overtone Order	OT	Fundamental	—	
Frequency Tolerance	f _{tol}	±10	×10 ⁻⁶	@ 25°C
Frequency Temp. Characteristics	f _{tem}	±15	×10 ⁻⁶	ref.@ 25°C Over Operating Temp. Range
Motional Series Resistance	R1	Table 1	ohm	
Level of Drive	DL	Table 2	μW	
Load Capacitance	CL	8	pF	
Operating Temp. Range	T _{use}	-30 to +85	°C	
Storage Temp. Range	T _{stg}	-40 to +85	°C	

* Please inquire about specifications other than the above.

Table1 Motional Series Resistances

Frequency Range	Motional Series Resistance	Units
12000 to 13999kHz	300	ohm
14000 to 15999kHz	200	
16000 to 26999kHz	100	
27000 to 54000kHz	50	

Table2 Level of Drive

Frequency Range	Level of Drive	Units
12000 to 54000kHz	10 (100 max.)	μW

Dimensions

(Unit : mm)

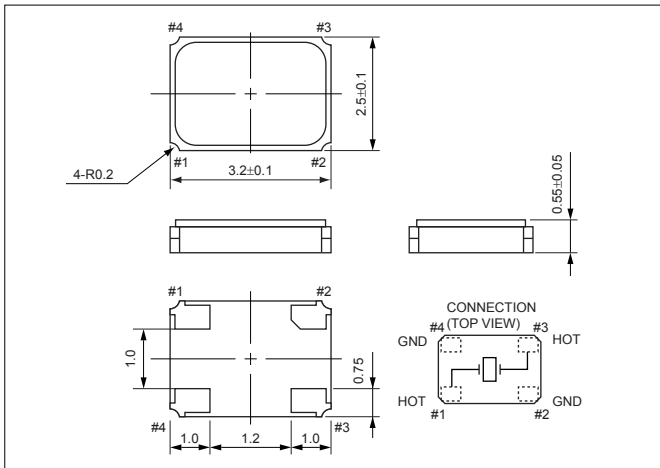

Recommended Land Pattern

(Unit : mm)

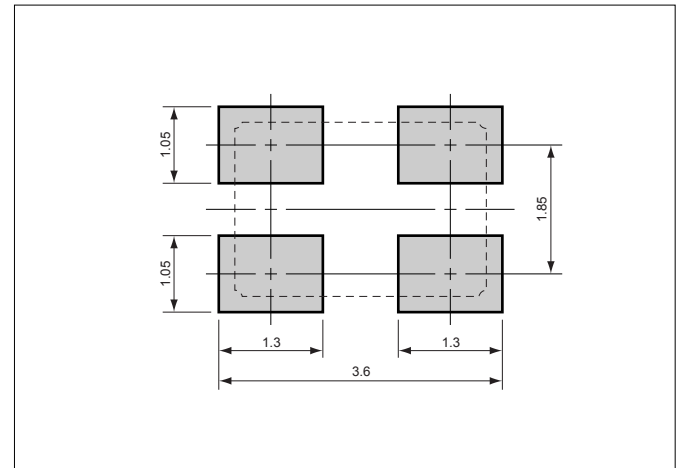

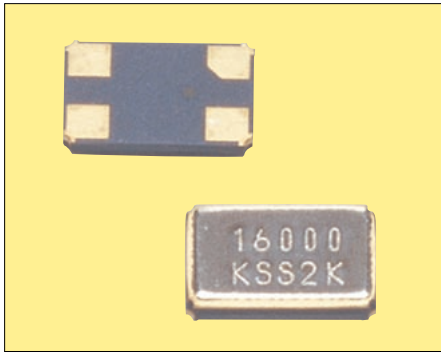

Pb Free

RoHS Compliant

Features

- Reference frequency for telecommunication systems
- Reflow compatible
- Using ceramic package resulting in high reliability
- Small and low profile

Applications

- Mobile Communications, Bluetooth, Wireless LAN

How to Order

CX4025SB 26000 F0 F L J ZZ
① ② ③ ④ ⑤ ⑥ ⑦

① Code

② Typical Frequencies

Code	Freq.(kHz)	Code	Freq.(kHz)
12000	12000.000	26000	26000.000
13000	13000.000	32000	32000.000
16000	16000.000	40000	40000.000
20000	20000.000		

*Please inquire about frequencies other than the above.

③ Load Capacitance

F0	10pF
-----------	------

④ Frequency Stability

F	$\pm 10 \times 10^{-6}$
----------	-------------------------

⑤ Operating Temperature Range

L	-30°C to +85°C
----------	----------------

⑥ Frequency Temperature Stability

J	$\pm 15 \times 10^{-6}$
----------	-------------------------

⑦ Special

ZZ	Custom Specification
-----------	----------------------

Specifications

Items	Symbol	Specification	Units	Remarks
Frequency Range	f _{nom}	12000 to 40000	kHz	
Overtone Order	OT	Fundamental	—	
Frequency Tolerance	f _{tol}	± 10	$\times 10^{-6}$	@ 25°C
Frequency Temp. Characteristics	f _{tem}	± 15	$\times 10^{-6}$	ref.@ 25°C Over Operating Temp. Range
Motional Series Resistance	R1	Table 1	ohm	
Level of Drive	DL	Table 2	μ W	
Load Capacitance	CL	10	pF	
Operating Temp. Range	T _{use}	-30 to +85	°C	
Storage Temp. Range	T _{stg}	-40 to +85	°C	

* Please inquire about specifications other than the above.

Table1 Motional Series Resistances

Frequency Range	Motional Series Resistance	Units
12000 to 19999kHz	80	ohm
20000 to 40000kHz	50	

Table2 Level of Drive

Frequency Range	Level of Drive	Units
12000 to 40000kHz	10 (100 max.)	μ W

Dimensions

(Unit : mm)

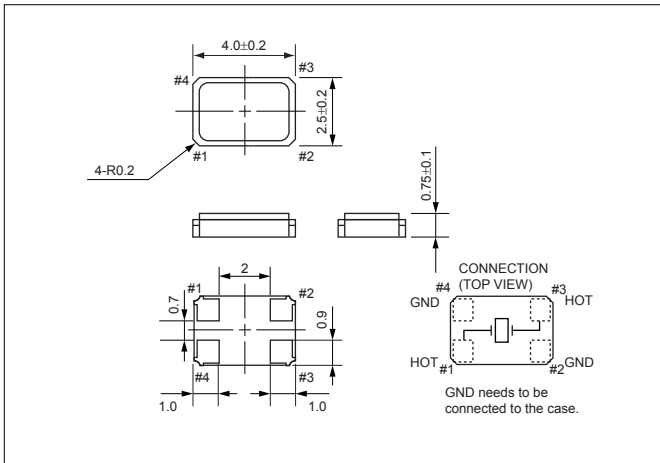

Recommended Land Pattern

(Unit : mm)

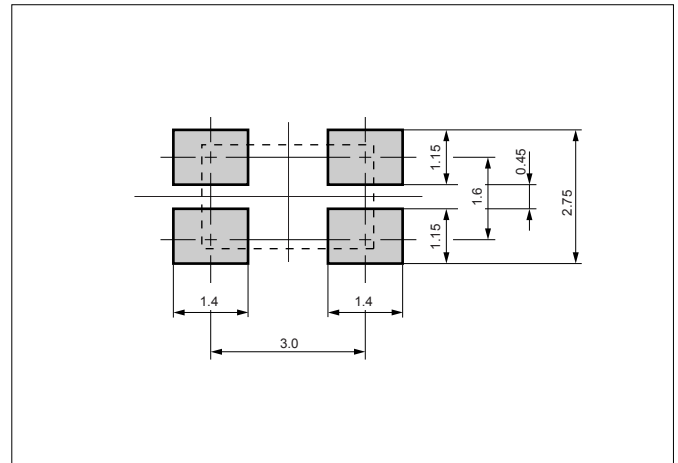

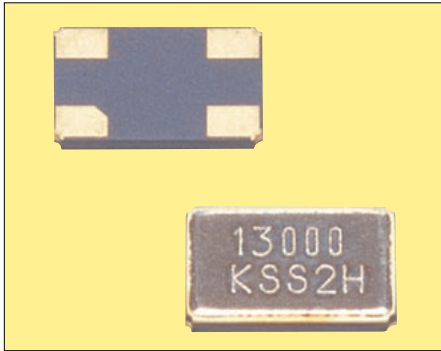

Pb Free

RoHS Compliant

Features

- Reference frequency for telecommunication systems
- Reflow compatible
- Using ceramic package resulting in high reliability
- Small and low profile

Applications

- Mobile Communications, Bluetooth, Wireless LAN

How to Order

CX5032SB 26000 F0 F L J ZZ
 ① ② ③ ④ ⑤ ⑥ ⑦

① Code

② Typical Frequencies

Code	Freq.(kHz)	Code	Freq.(kHz)
12000	12000.000	19200	19200.000
12800	12800.000	26000	26000.000
13000	13000.000	32000	32000.000
14400	14400.000	40000	40000.000
16000	16000.000	48000	48000.000

*Please inquire about frequencies other than the above.

③ Load Capacitance

F0	10pF
-----------	------

④ Frequency Stability

F	±10×10 ⁻⁶
----------	----------------------

⑤ Operating Temperature Range

L	-30°C to +85°C
----------	----------------

⑥ Frequency Temperature Stability

J	±15×10 ⁻⁶
----------	----------------------

⑦ Special

ZZ	Custom Specification
-----------	----------------------

Specifications

Items	Symbol	Specification	Units	Remarks
Frequency Range	f _{nom}	9843.75 to 49999	50 to 120(MHz)	kHz
Overtone Order	OT	Fundamental	3rd Overtone	—
Frequency Tolerance	f _{tol}	±10	×10 ⁻⁶	@ 25°C
Frequency Temp. Characteristics	f _{tem}	±15	×10 ⁻⁶	ref.@ 25°C Over Operating Temp. Range
Motional Series Resistance	R1	Table 1		ohm
Level of Drive	DL	Table 2		μW
Load Capacitance	CL	10		pF
Operating Temp. Range	T _{use}	-30 to +85		°C
Storage Temp. Range	T _{stg}	-40 to +85		°C

* Please inquire about specifications other than the above.

Table1 Motional Series Resistances

Frequency Range	Motional Series Resistance	Units
9843.75 to 9999kHz	150	ohm
10000 to 11999kHz	80	
12000 to 25999kHz	50	
26000 to 49999kHz	40	
50 to 120(MHz)	80	

Table2 Level of Drive

Frequency Range	Level of Drive	Units
9843.75 to 49999kHz	10 (100 max.)	μW
50 to 120(MHz)(3rdO.T)	10 (100 max.)	

Dimensions

(Unit : mm)

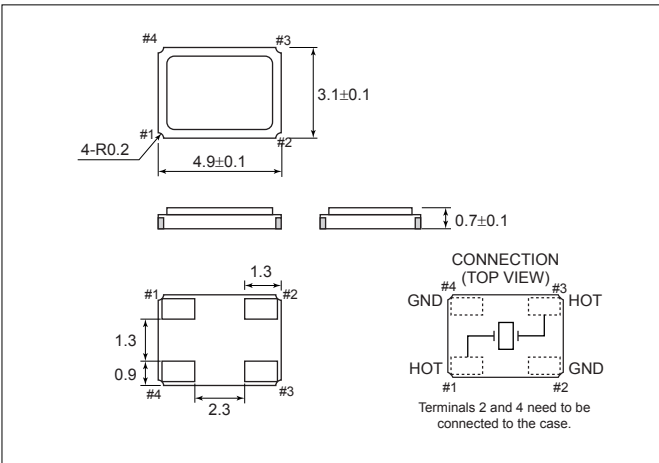

Recommended Land Pattern

(Unit : mm)

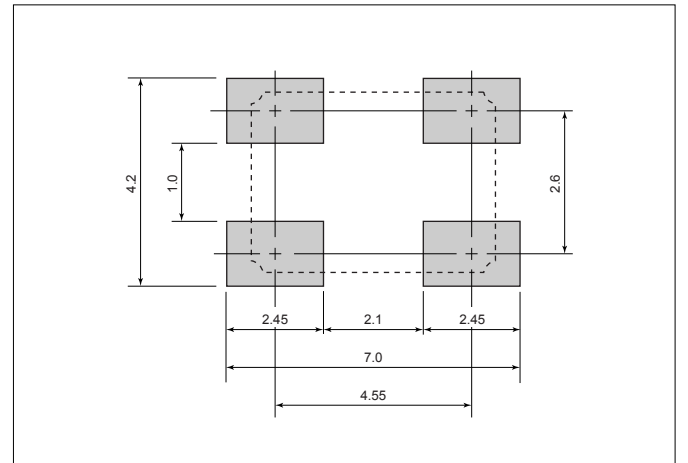

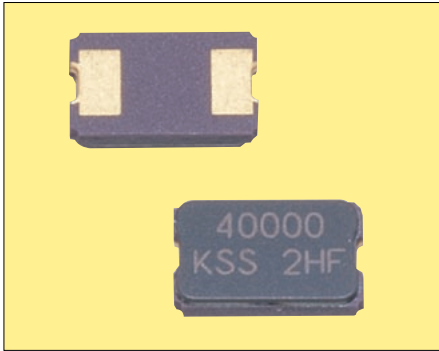

RoHS Compliant

Features

- Crystal unit for audio-visual, office equipment
- Small and low profile (5.0x3.2x1.0mm)
- Ceramic package
- Product with lead free terminations
- Reflow compatible

Applications

- Digital Electronics
- Audio-Visual, Office Equipment

How to Order

CX5032GB 48000 H0 P E S ZZ
 ① ② ③ ④ ⑤ ⑥ ⑦

- ① Code
- ② Typical Frequencies

Code	Freq.(kHz)	Code	Freq.(kHz)
10000	10000.000	24000	24000.000
12000	12000.000	24545	24545.450
14318	14318.180	24576	24576.000
14745	14745.600	27000	27000.000
16934	16934.400	36000	36000.000
18432	18432.000	48000	48000.000
22579	22579.200	54000	54000.000

*Please inquire about frequencies other than the above.

③ Load Capacitance

H0	12pF
-----------	------

④ Frequency Stability

P	$\pm 50 \times 10^{-6}$
----------	-------------------------

⑤ Operating Temperature Range

E	-10°C to +70°C
----------	----------------

⑥ Frequency Temperature Stability

S	$\pm 50 \times 10^{-6}$
----------	-------------------------

⑦ Special

ZZ	Custom Specification
-----------	----------------------

Specifications

Items	Symbol	Specification	Units	Remarks
Frequency Range	f _{nom}	9843.75 to 54000	kHz	
Overtone Order	OT	Fundamental	—	
Frequency Tolerance	f _{tol}	±50	×10 ⁻⁶	@ 25°C
Frequency Temp. Characteristics	f _{tem}	±50	×10 ⁻⁶	ref.@ 25°C Over Operating Temp. Range
Motional Series Resistance	R1	Table 1	ohm	
Level of Drive	DL	Table 2	μW	
Load Capacitance	CL	12	pF	
Operating Temp. Range	T _{use}	-10 to +70	°C	
Storage Temp. Range	T _{stg}	-40 to +85	°C	

* Please inquire about specifications other than the above.

Table1 Motional Series Resistances

Frequency Range	Motional Series Resistance	Units
9843.75 to 11999kHz	200	ohm
12000 to 13999kHz	150	
14000 to 29999kHz	100	
30000 to 54000kHz	50	

Table2 Level of Drive

Frequency Range	Level of Drive	Units
9843.75 to 15999kHz	10 (500 max.)	μW
16000 to 24999kHz	10 (300 max.)	
25000 to 54000kHz	10 (100 max.)	

Dimensions

(Unit : mm)

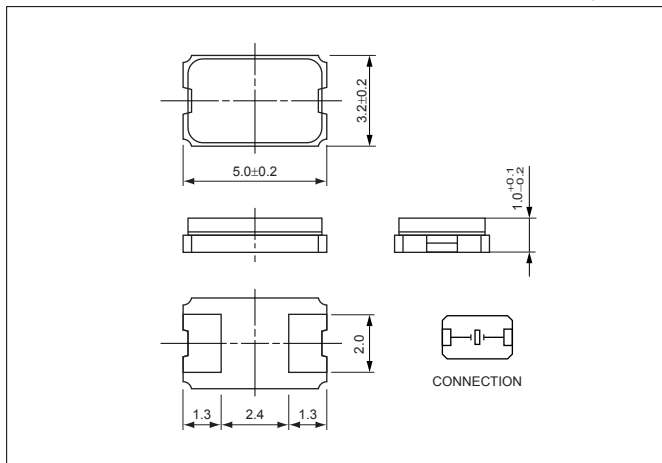

Recommended Land Pattern

(Unit : mm)

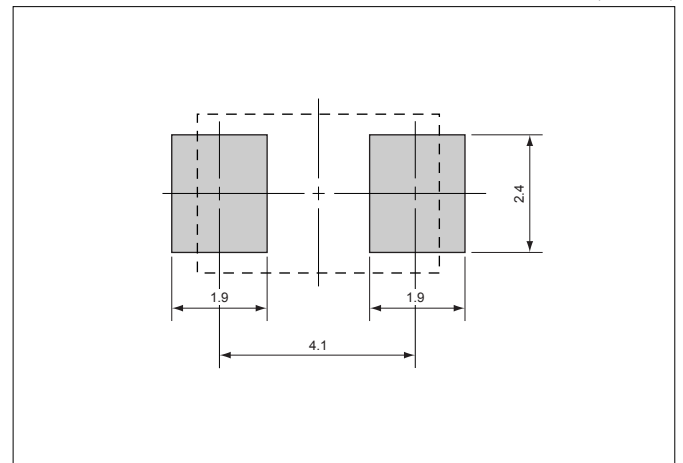



RoHS Compliant

Features

- Crystal unit for audio-visual, office equipment
- Small and low profile (8.0x4.5x1.8mm)
- Ceramic package
- Product with lead free terminations
- Reflow compatible

Applications

- Audio-Visual, Office Equipment

How to Order

CX8045GB 30000 H0 P E S ZZ
 ① ② ③ ④ ⑤ ⑥ ⑦

- ① Code
- ② Typical Frequencies

Code	Freq.(kHz)	Code	Freq.(kHz)
14318	14318.180	24576	24576.000
16000	16000.000	27000	27000.000
16384	16384.000	28636	28636.000
16934	16934.400	30000	30000.000
19660	19660.800	32000	32000.000
20000	20000.000	36000	36000.000
21477	21477.720	40000	40000.000
24000	24000.000		

*Please inquire about frequencies other than the above.

③ Load Capacitance

H0	12pF
----	------

④ Frequency Stability

P	$\pm 50 \times 10^{-6}$
---	-------------------------

⑤ Operating Temperature Range

E	-10°C to +70°C
---	----------------

⑥ Frequency Temperature Stability

S	$\pm 50 \times 10^{-6}$
---	-------------------------

⑦ Special

ZZ	Custom Specification
----	----------------------

Specifications

Items	Symbol	Specification	Units	Remarks
Frequency Range	f _{nom}	7200 to 48000	kHz	
Overtone Order	OT	Fundamental	—	
Frequency Tolerance	f _{tol}	± 50	$\times 10^{-6}$	@ 25°C
Frequency Temp. Characteristics	f _{tem}	± 50	$\times 10^{-6}$	ref.@ 25°C Over Operating Temp. Range
Motional Series Resistance	R1	Table 1	ohm	
Level of Drive	DL	Table 2	μ W	
Load Capacitance	CL	12	pF	
Operating Temp. Range	T _{use}	-10 to +70	°C	
Storage Temp. Range	T _{stg}	-40 to +85	°C	

* Please inquire about specifications other than the above.

Table1 Motional Series Resistances

Frequency Range	Motional Series Resistance	Units
7200 to 9999kHz	200	ohm
10000 to 11999kHz	150	
12000 to 48000kHz	50	

Table2 Level of Drive

Frequency Range	Level of Drive	Units
7200 to 9999kHz	10 (500 max.)	μ W
16000 to 24999kHz	10 (300 max.)	
25000 to 48000kHz	10 (100 max.)	

Dimensions

(Unit : mm)

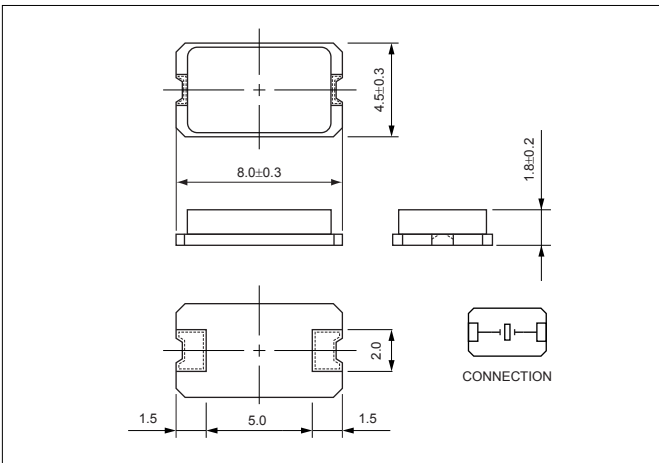

Recommended Land Pattern

(Unit : mm)

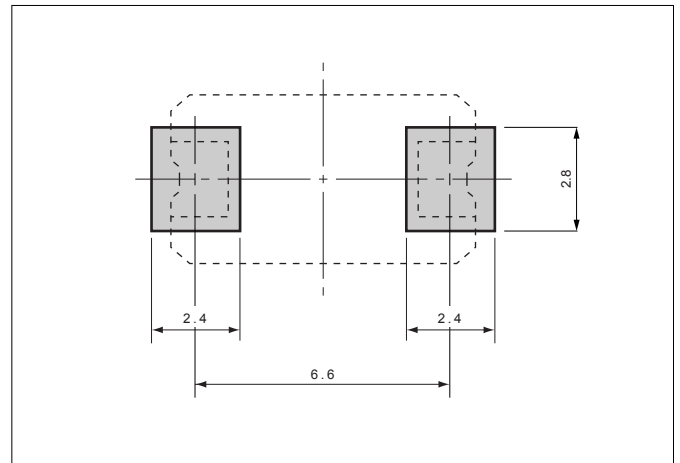

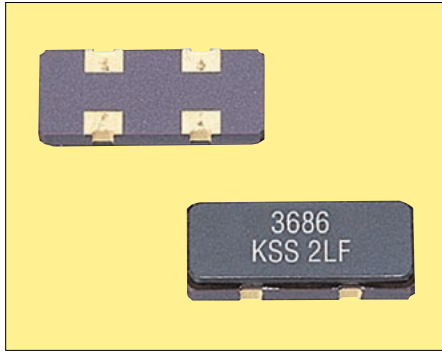

RoHS Compliant

Features

- Crystal unit for audio-visual, office equipment
- Small and low profile (11.8x5.5x1.8mm)
- Ceramic package
- Product with lead free terminations
- Reflow compatible

Applications

- Digital Electronics
- Audio-Visual, Office Equipment

How to Order

CXB855GB 03579 H0 P E S ZZ
 ① ② ③ ④ ⑤ ⑥ ⑦

- ① Code
- ② Typical Frequencies

Code	Freq.(kHz)	Code	Freq.(kHz)
03579	3579.545	14318	14318.180
03686	3686.400	16000	16000.000
04000	4000.000	16934	16934.400
06000	6000.000	19660	19660.800
08000	8000.000	20000	20000.000
12000	12000.000		

*Please inquire about frequencies other than the above.

- ③ Load Capacitance

H0	12pF
----	------

- ④ Frequency Stability

P	±50×10 ⁻⁶
---	----------------------

- ⑤ Operating Temperature Range

E	-10°C to +70°C
---	----------------

- ⑥ Frequency Temperature Stability

S	±50×10 ⁻⁶
---	----------------------

- ⑦ Special

ZZ	Custom Specification
----	----------------------

Specifications

Items	Symbol	Specification		Units	Remarks
Frequency Range	f _{nom}	3500 to 28999	29 to 60(MHz)	kHz	
Overtone Order	OT	Fundamental	3rd Overtone	—	
Frequency Tolerance	f _{tol}	±50		×10 ⁻⁶	@ 25°C
Frequency Temp. Characteristics	f _{tem}	±50		×10 ⁻⁶	ref. @ 25°C Over Operating Temp. Range
Motional Series Resistance	R1	Table 1		ohm	
Level of Drive	DL	Table 2		μW	
Load Capacitance	CL	12		pF	
Operating Temp. Range	T _{use}	-10 to +70		°C	
Storage Temp. Range	T _{stg}	-40 to +85		°C	

* Please inquire about specifications other than the above.

Table1 Motional Series Resistances

Frequency Range	Motional Series Resistance	Units
3500 to 3999kHz	300	ohm
4000 to 7999kHz	200	
8000 to 11999kHz	120	
12000 to 28999kHz	100	
29 to 60MHz	150	

Table2 Level of Drive

Frequency Range	Level of Drive	Units
3500 to 15999kHz	10 (500 max.)	μW
16000 to 28999kHz	10 (300 max.)	
29 to 60MHz	10 (300 max.)	

Dimensions

(Unit : mm)

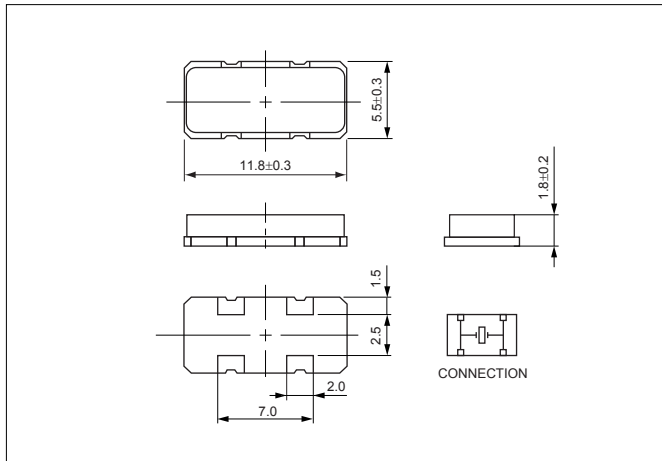

Recommended Land Pattern

(Unit : mm)

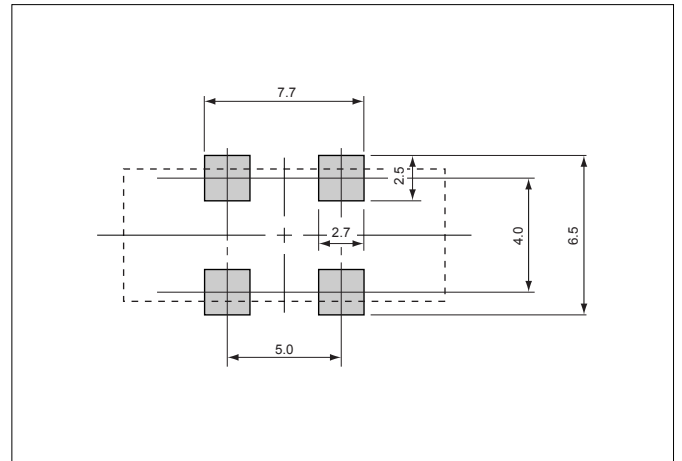

查询"CX5032GB14318H0PESZZ" 供应商

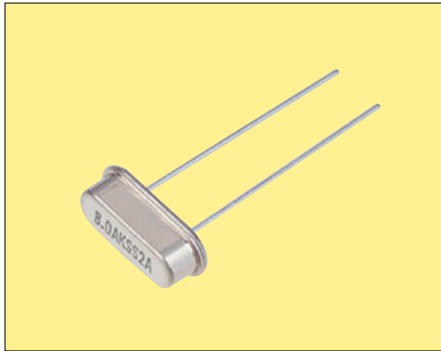

Pb Free

RoHS Compliant

Features

- Crystal unit for audio-visual, office equipment
- Metal package, leaded type
- A resistance weld hermetic sealed type
- Suitable for high density assembly and mass production

Applications

- Digital Electronics
- Audio-Visual, Office Equipment

How to Order

CXH49SFB 03579 H0 P E S ZZ
 ① ② ③ ④ ⑤ ⑥ ⑦

- ① Code
- ② Typical Frequencies

Code	Freq.(kHz)	Code	Freq.(kHz)
03200	3200.000	11000	11000.000
03579	3579.545	11059	11059.200
03686	3686.400	12000	12000.000
04000	4000.000	12288	12288.000
04194	4194.304	13500	13500.000
04332	4332.000	14318	14318.180
04433	4433.619	16000	16000.000
04500	4500.000	16934	16934.400
04915	4915.200	17280	17280.000
06000	6000.000	17734	17734.476
06144	6144.000	20000	20000.000
07200	7200.000	21477	21477.270
07372	7372.800	24000	24000.000
08000	8000.000	24576	24576.000
10000	10000.000	25000	25000.000
10240	10240.000	27000	27000.000
10738	10738.635		

*Please inquire about frequencies other than the above.

③ Load Capacitance

H0	12pF
-----------	------

④ Frequency Stability

P	$\pm 50 \times 10^{-6}$
----------	-------------------------

⑤ Operating Temperature Range

E	-10°C to +70°C
----------	----------------

⑥ Frequency Temperature Stability

S	$\pm 50 \times 10^{-6}$
----------	-------------------------

⑦ Special

ZZ	Custom Specification
-----------	----------------------

Specifications

Items	Symbol	Specification	Units	Remarks
Frequency Range	f _{nom}	3200 to 33999, 30 to 60(MHz)	kHz	
Overtone Order	OT	Fundamental, 3rd Overtone	—	
Frequency Tolerance	f _{tol}	±50	$\times 10^{-6}$	@ 25°C
Frequency Temp. Characteristics	f _{tem}	±50	$\times 10^{-6}$	ref.@ 25°C Over Operating Temp. Range
Motional Series Resistance	R1	Table 1	ohm	
Level of Drive	DL	Table 2	μW	
Load Capacitance	CL	12	pF	
Operating Temp. Range	T _{use}	-10 to +70	°C	
Storage Temp. Range	T _{stg}	-40 to +85	°C	

* Please inquire about specifications other than the above.

Table1 Motional Series Resistances

Frequency Range	Motional Series Resistance	Units
3200 to 3499kHz	300	ohm
3500 to 4099kHz	150	
4100 to 4799kHz	120	
4800 to 5999kHz	100	
6000 to 11999kHz	90	
12000 to 13499kHz	70	
13500 to 33999kHz	50	
30 to 60MHz	150	

Table2 Level of Drive

Frequency Range	Level of Drive	Units
3200 to 15999kHz	10 (500 max.)	μW
16000 to 24999kHz	10 (300 max.)	
25000 to 33999kHz	10 (100 max.)	
30 to 60MHz	10 (300 max.)	

Recommended Land Pattern

(Unit : mm)

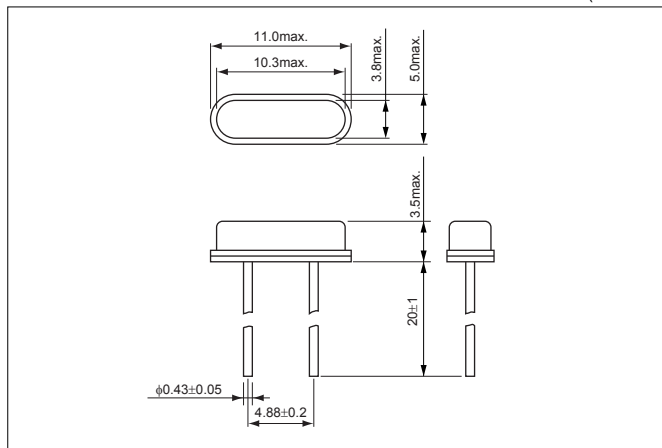



Pb Free

RoHS Compliant

Features

- Crystal unit for audio-visual, office equipment
- Metal package, leaded type
- A resistance weld hermetic sealed type
- Suitable for high density assembly and mass production

Applications

- Digital Electronics
- Audio-Visual, Office Equipment

How to Order

CXZ49GFB 03579 H0 P E S ZZ
 ① ② ③ ④ ⑤ ⑥ ⑦

① Code

② Typical Frequencies

Code	Freq.(kHz)	Code	Freq.(kHz)
03200	3200.000	11000	11000.000
03579	3579.545	11059	11059.200
03686	3686.400	12000	12000.000
04000	4000.000	12288	12288.000
04194	4194.304	13500	13500.000
04332	4332.000	14318	14318.180
04433	4433.619	16000	16000.000
04500	4500.000	16934	16934.400
04915	4915.200	17280	17280.000
06000	6000.000	17734	17734.476
06144	6144.000	20000	20000.000
07200	7200.000	21477	21477.270
07372	7372.800	24000	24000.000
08000	8000.000	24576	24576.000
10000	10000.000	25000	25000.000
10240	10240.000	27000	27000.000
10738	10738.635		

*Please inquire about frequencies other than the above.

③ Load Capacitance

H0	12pF
-----------	------

④ Frequency Stability

P	±50×10 ⁻⁶
----------	----------------------

⑤ Operating Temperature Range

E	-10°C to +70°C
----------	----------------

⑥ Frequency Temperature Stability

S	±50×10 ⁻⁶
----------	----------------------

⑦ Special

ZZ	Custom Specification
-----------	----------------------

Specifications

Items	Symbol	Specification	Units	Remarks
Frequency Range	f _{nom}	3200 to 33999, 30 to 60(MHz)	kHz	
Overtone Order	OT	Fundamental, 3rd Overtone	—	
Frequency Tolerance	f _{tol}	±50	×10 ⁻⁶	@ 25°C
Frequency Temp. Characteristics	f _{tem}	±50	×10 ⁻⁶	ref.@ 25°C Over Operating Temp. Range
Motional Series Resistance	R1	Table 1	ohm	
Level of Drive	DL	Table 2	μW	
Load Capacitance	CL	12	pF	
Operating Temp. Range	T _{use}	-10 to +70	°C	
Storage Temp. Range	T _{stg}	-40 to +85	°C	

* Please inquire about specifications other than the above.

Table1 Motional Series Resistances

Frequency Range	Motional Series Resistance	Units
3200 to 3499kHz	300	ohm
3500 to 4099kHz	150	
4100 to 4799kHz	120	
4800 to 5999kHz	100	
6000 to 11999kHz	90	
12000 to 13499kHz	70	
13500 to 33999kHz	50	
30 to 60MHz	150	

Table2 Level of Drive

Frequency Range	Level of Drive	Units
3200 to 15999kHz	10 (500 max.)	μW
16000 to 24999kHz	10 (300 max.)	
25000 to 33999kHz	10 (100 max.)	
30 to 60MHz	10 (300 max.)	

Dimensions

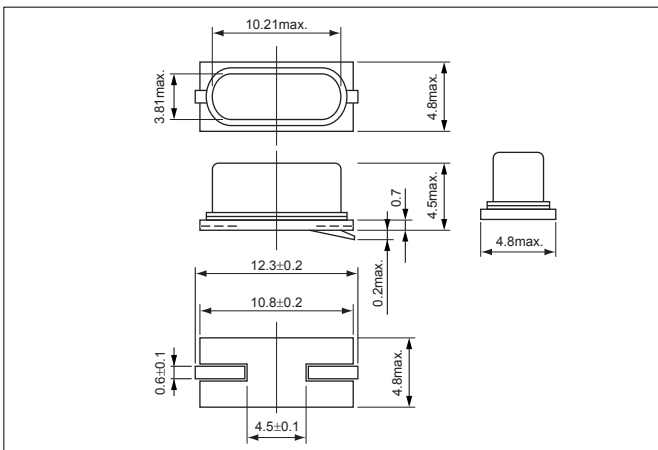

Recommended Land Pattern

(Unit : mm)

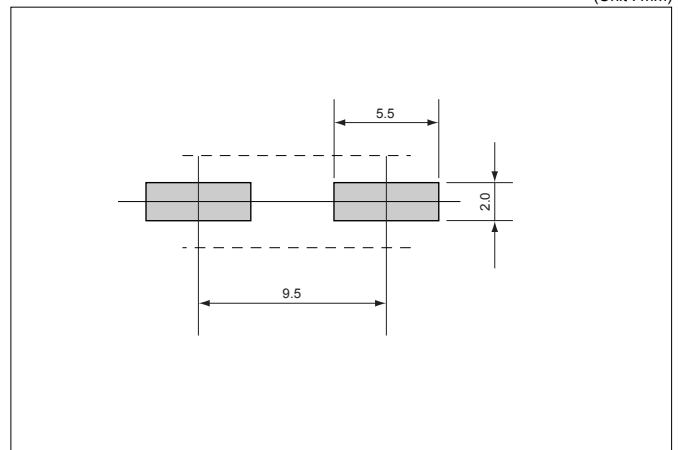



RoHS Compliant

Features

- Crystal unit for automotive electronics
- Small and low profile (5.0x3.2x1.3mm)
- Ceramic package
- Product with lead free terminations
- Reflow compatible

Applications

- Engine Control

How to Order

CX5032GA 16000 H0 Q S W ZZ
① ② ③ ④ ⑤ ⑥ ⑦

① Code

② Typical Frequencies

Code	Freq.(kHz)	Code	Freq.(kHz)
10000	10000.000	18000	18000.000
12000	12000.000	20000	20000.000
15000	15000.000	24000	24000.000
16000	16000.000	25000	25000.000

*Please inquire about frequencies other than the above.

③ Load Capacitance

H0	12pF
-----------	------

④ Frequency Stability

Q	$\pm 100 \times 10^{-6}$
----------	--------------------------

⑤ Operating Temperature Range

S	-40°C to +125°C
----------	-----------------

⑥ Frequency Temperature Stability

W	$\pm 200 \times 10^{-6}$
----------	--------------------------

⑦ Special

ZZ	Custom Specification
-----------	----------------------

Specifications

Items	Symbol	Specification	Units	Remarks
Frequency Range	f _{nom}	9843.75 to 40000	kHz	
Overtone Order	OT	Fundamental	—	
Frequency Tolerance	f _{tol}	± 100	$\times 10^{-6}$	@ 25°C
Frequency Temp. Characteristics	f _{tem}	± 200	$\times 10^{-6}$	ref.@ 25°C Over Operating Temp. Range
Motional Series Resistance	R1	Table 1	ohm	
Level of Drive	DL	Table 2	μ W	
Load Capacitance	CL	12	pF	
Operating Temp. Range	T _{use}	-40 to +125	°C	
Storage Temp. Range	T _{stg}	-40 to +150	°C	

* Please inquire about specifications other than the above.

Table1 Motional Series Resistances

Frequency Range	Motional Series Resistance	Units
9843.75 to 11999kHz	200	ohm
12000 to 13999kHz	150	
14000 to 29999kHz	100	
30000 to 40000kHz	50	

Table2 Level of Drive

Frequency Range	Level of Drive	Units
9843.75 to 15999kHz	10 (500 max.)	μ W
16000 to 24999kHz	10 (300 max.)	
25000 to 40000kHz	10 (100 max.)	

Dimensions

(Unit : mm)

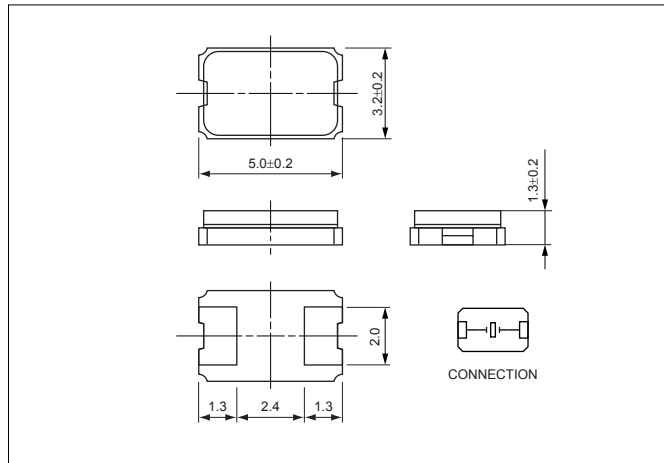

Recommended Land Pattern

(Unit : mm)

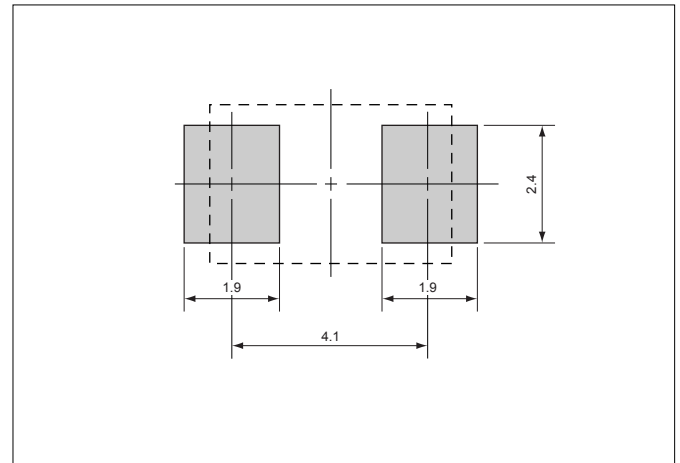

8.0x4.5mm for Automotive
[查询"CX5032GB14318H0PESZZ" 供应商](#)



RoHS Compliant

Features

- Crystal unit for automotive electronics
- Small and low profile (8.0x4.5x1.9mm)
- Ceramic package, J lead type
- Product with lead free terminations
- Reflow compatible

Applications

- Engine Control, TPMS

How to Order

CX8045JA 08000 H0 Q S W ZZ
① ② ③ ④ ⑤ ⑥ ⑦

① Code

② Typical Frequencies

Code	Freq.(kHz)	Code	Freq.(kHz)
08000	8000.000	16000	16000.000
09843	9843.750	18000	18000.000
10000	10000.000	20000	20000.000
12000	12000.000	24000	24000.000
13560	13560.000	25000	25000.000
14000	14000.000	30000	30000.000

*Please inquire about frequencies other than the above.

③ Load Capacitance

H0	12pF
----	------

④ Frequency Stability

Q	$\pm 100 \times 10^{-6}$
---	--------------------------

⑤ Operating Temperature Range

S	-40°C to +125°C
---	-----------------

⑥ Frequency Temperature Stability

W	$\pm 200 \times 10^{-6}$
---	--------------------------

⑦ Special

ZZ	Custom Specification
----	----------------------

Specifications

Items	Symbol	Specification	Units	Remarks
Frequency Range	f _{nom}	8000 to 30000	kHz	
Overtone Order	OT	Fundamental	—	
Frequency Tolerance	f _{tol}	± 100	$\times 10^{-6}$	@ 25°C
Frequency Temp. Characteristics	f _{tem}	± 200	$\times 10^{-6}$	ref.@ 25°C Over Operating Temp. Range
Motional Series Resistance	R1	Table 1	ohm	
Level of Drive	DL	Table 2	μ W	
Load Capacitance	CL	12	pF	
Operating Temp. Range	T _{use}	-40 to +125	°C	
Storage Temp. Range	T _{stg}	-40 to +150	°C	

*Please inquire about specifications other than the above.

Table1 Motional Series Resistances

Frequency Range	Motional Series Resistance	Units
8000 to 9999kHz	200	ohm
10000 to 11999kHz	150	
12000 to 30000kHz	100	

Table2 Level of Drive

Frequency Range	Level of Drive	Units
8000 to 15999kHz	10 (500 max.)	μ W
16000 to 24999kHz	10 (300 max.)	
25000 to 30000kHz	10 (100 max.)	

Dimensions

(Unit : mm)

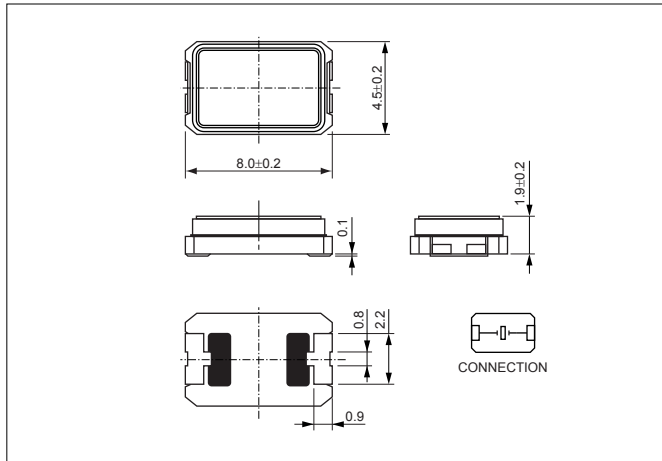

Recommended Land Pattern

(Unit : mm)

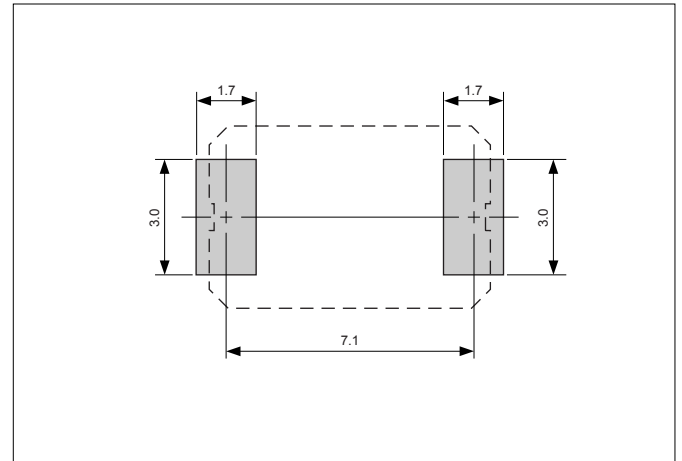

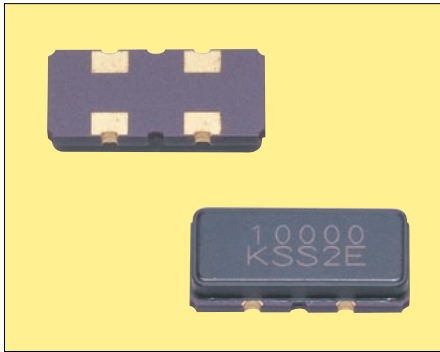

RoHS Compliant

Features

- Crystal unit for automotive electronics
- Small and low profile (11.8×5.5×2.5mm)
- Ceramic package
- Product with lead free terminations
- Reflow compatible

Applications

- Engine Control

How to Order

CXB855GA 06000 H0 Q S W ZZ
 ① ② ③ ④ ⑤ ⑥ ⑦

- ① Code
- ② Typical Frequencies

Code	Freq.(kHz)	Code	Freq.(kHz)
04000	4000.000	12000	12000.000
05000	5000.000	16000	16000.000
06000	6000.000	18000	18000.000
08000	8000.000	20000	20000.000
10000	10000.000		

*Please inquire about frequencies other than the above.

- ③ Load Capacitance

H0	12pF
-----------	------

- ④ Frequency Stability

Q	±100×10 ⁻⁶
----------	-----------------------

- ⑤ Operating Temperature Range

S	-40°C to +125°C
----------	-----------------

- ⑥ Frequency Temperature Stability

W	±200×10 ⁻⁶
----------	-----------------------

- ⑦ Special

ZZ	Custom Specification
-----------	----------------------

Specifications

Items	Symbol	Specification	Units	Remarks
Frequency Range	f _{nom}	3500 to 20000	kHz	
Overtone Order	OT	Fundamental	—	
Frequency Tolerance	f _{tol}	±100	×10 ⁻⁶	@ 25°C
Frequency Temp. Characteristics	f _{tem}	±200	×10 ⁻⁶	ref.@ 25°C Over Operating Temp. Range
Motional Series Resistance	R1	Table 1	ohm	
Level of Drive	DL	Table 2	μW	
Load Capacitance	CL	12	pF	
Operating Temp. Range	T _{use}	-40 to +125	°C	
Storage Temp. Range	T _{stg}	-40 to +125	°C	

* Please inquire about specifications other than the above.

Table1 Motional Series Resistances

Frequency Range	Motional Series Resistance	Units
3500 to 3999kHz	300	ohm
4000 to 7999kHz	200	
8000 to 11999kHz	120	
12000 to 20000kHz	100	

Table2 Level of Drive

Frequency Range	Level of Drive	Units
3500 to 15999kHz	10 (500 max.)	μW
16000 to 20000kHz	10 (300 max.)	

Dimensions

(Unit : mm)

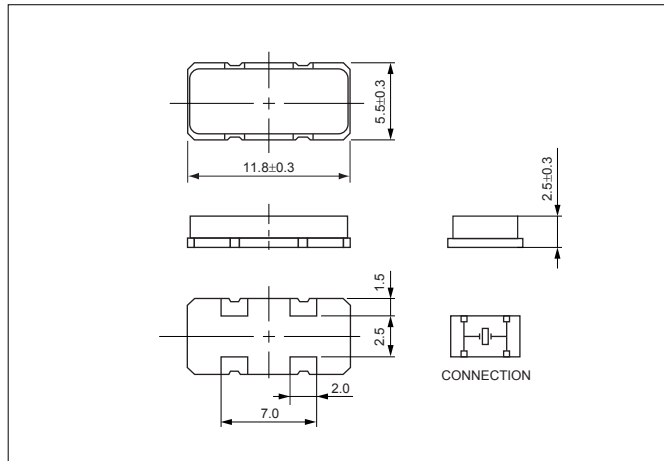

Recommended Land Pattern

(Unit : mm)

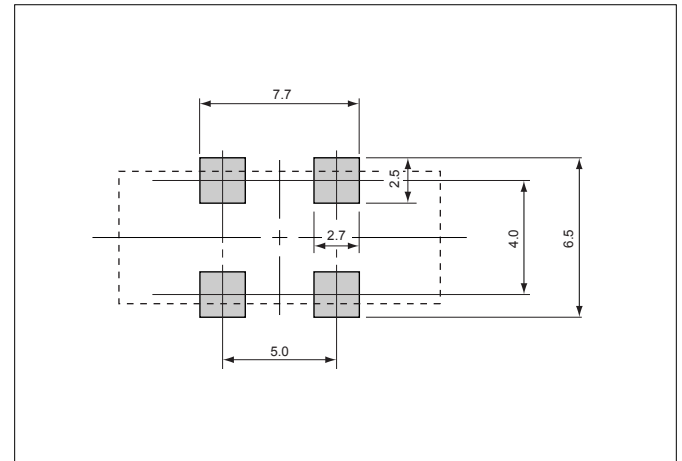

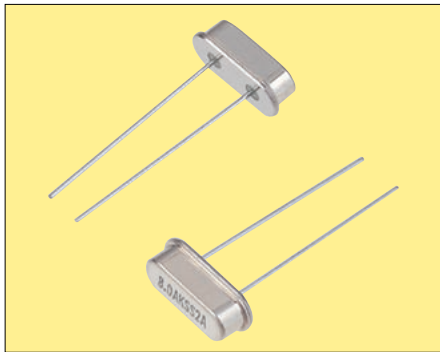

Pb Free

RoHS Compliant

Features

- Crystal unit for automotive electronics
- Metal package, leaded type
- A resistance weld hermetic sealed type
- Suitable for high density assembly and mass production

Applications

- Engine Control

How to Order

CXH49SFA 06000 H0 Q S W ZZ
 ① ② ③ ④ ⑤ ⑥ ⑦

- ① Code
- ② Typical Frequencies

Code	Freq.(kHz)	Code	Freq.(kHz)
04000	4000.000	12000	12000.000
05000	5000.000	16000	16000.000
06000	6000.000	18000	18000.000
08000	8000.000	20000	20000.000
10000	10000.000		

*Please inquire about frequencies other than the above.

- ③ Load Capacitance

H0	12pF
-----------	------

- ④ Frequency Stability

Q	±100×10 ⁻⁶
----------	-----------------------

- ⑤ Operating Temperature Range

S	-40°C to +125°C
----------	-----------------

- ⑥ Frequency Temperature Stability

W	±200×10 ⁻⁶
----------	-----------------------

- ⑦ Special

ZZ	Custom Specification
-----------	----------------------

Specifications

Items	Symbol	Specification	Units	Remarks
Frequency Range	f _{nom}	3200 to 20000	kHz	
Overtone Order	OT	Fundamental	—	
Frequency Tolerance	f _{tol}	±100	×10 ⁻⁶	@ 25°C
Frequency Temp. Characteristics	f _{tem}	±200	×10 ⁻⁶	ref.@ 25°C Over Operating Temp. Range
Motional Series Resistance	R1	Table 1	ohm	
Level of Drive	DL	Table 2	μW	
Load Capacitance	CL	12	pF	
Operating Temp. Range	T _{use}	-40 to +125	°C	
Storage Temp. Range	T _{stg}	-40 to +125	°C	

* Please inquire about specifications other than the above.

Table1 Motional Series Resistances

Frequency Range	Motional Series Resistance	Units
3200 to 3499kHz	300	ohm
3500 to 4099kHz	150	
4100 to 4799kHz	120	
4800 to 5999kHz	100	
6000 to 11999kHz	90	
12000 to 13499kHz	70	
13500 to 20000kHz	50	

Table2 Level of Drive

Frequency Range	Level of Drive	Units
3200 to 15999kHz	10 (500 max.)	μW
16000 to 20000kHz	10 (300 max.)	

Dimensions

(Unit : mm)

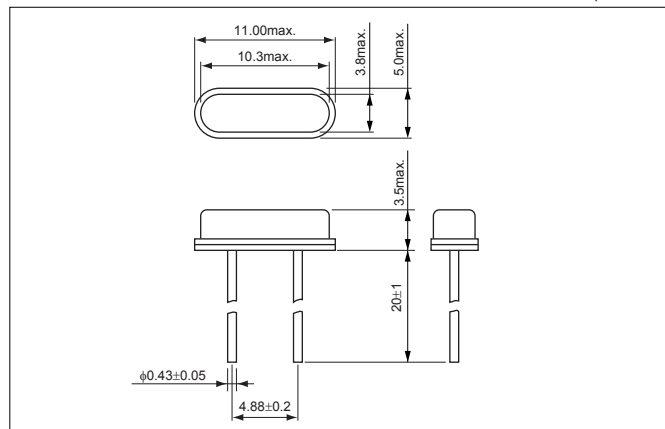



Pb Free **RoHS Compliant**

Features

- Crystal unit for automotive electronics
- Metal package, leaded type
- A resistance weld hermetic sealed type
- Suitable for high density assembly and mass production

Applications

- Engine Control

How to Order

CXZ49FFA 06000 H0 Q S W ZZ
 ① ② ③ ④ ⑤ ⑥ ⑦

- ① Code
- ② Typical Frequencies

Code	Freq.(kHz)	Code	Freq.(kHz)
04000	4000.000	12000	12000.000
05000	5000.000	16000	16000.000
06000	6000.000	18000	18000.000
08000	8000.000	20000	20000.000
10000	10000.000		

*Please inquire about frequencies other than the above.

- ③ Load Capacitance

H0	12pF
-----------	------

- ④ Frequency Stability

Q	±100×10 ⁻⁶
----------	-----------------------

- ⑤ Operating Temperature Range

S	-40°C to +125°C
----------	-----------------

- ⑥ Frequency Temperature Stability

W	±200×10 ⁻⁶
----------	-----------------------

- ⑦ Special

ZZ	Custom Specification
-----------	----------------------

Specifications

Items	Symbol	Specification	Units	Remarks
Frequency Range	f _{nom}	3200 to 20000	kHz	
Overtone Order	OT	Fundamental	—	
Frequency Tolerance	f _{tol}	±100	×10 ⁻⁶	@ 25°C
Frequency Temp. Characteristics	f _{tem}	±200	×10 ⁻⁶	ref.@ 25°C Over Operating Temp. Range
Motional Series Resistance	R1	Table 1	ohm	
Level of Drive	DL	Table 2	μW	
Load Capacitance	CL	12	pF	
Operating Temp. Range	T _{use}	-40 to +125	°C	
Storage Temp. Range	T _{stg}	-40 to +125	°C	

* Please inquire about specifications other than the above.

Table1 Motional Series Resistances

Frequency Range	Motional Series Resistance	Units
3200 to 3499kHz	300	ohm
3500 to 4099kHz	150	
4100 to 4799kHz	120	
4800 to 5999kHz	100	
6000 to 11999kHz	90	
12000 to 13499kHz	70	
13500 to 20000kHz	50	

Table2 Level of Drive

Frequency Range	Level of Drive	Units
3200 to 15999kHz	10 (500 max.)	μW
16000 to 20000kHz	10 (300 max.)	

Dimensions

(Unit : mm)

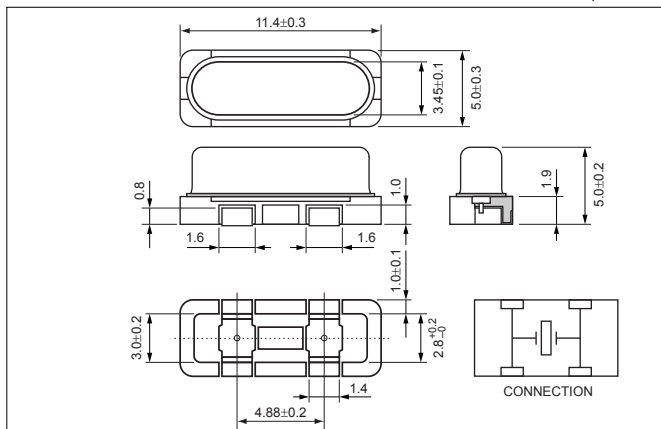

Recommended Land Pattern

(Unit : mm)

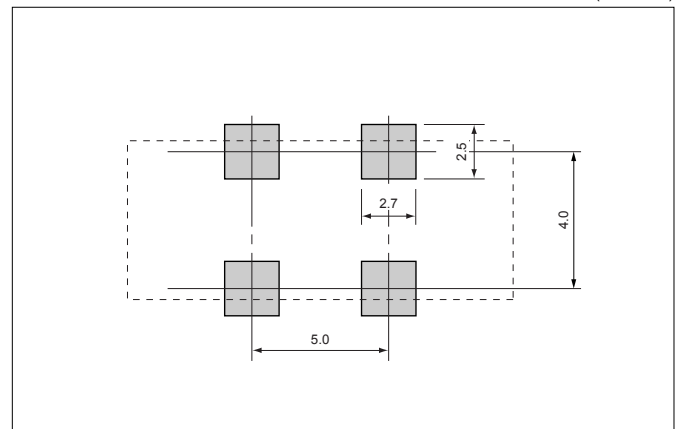



Features

- Crystal unit for automotive electronics
- Metal package, leaded type
- A resistance weld hermetic sealed type
- Suitable for high density assembly and mass production

Applications

- Engine Control

How to Order

CXZ49LFA 06000 H0 Q S W ZZ
 ① ② ③ ④ ⑤ ⑥ ⑦

① Code

② Typical Frequencies

Code	Freq.(kHz)	Code	Freq.(kHz)
04000	4000.000	12000	12000.000
05000	5000.000	16000	16000.000
06000	6000.000	18000	18000.000
08000	8000.000	20000	20000.000
10000	10000.000		

*Please inquire about frequencies other than the above.

③ Load Capacitance

H0	12pF
----	------

④ Frequency Stability

Q	$\pm 100 \times 10^{-6}$
---	--------------------------

⑤ Operating Temperature Range

S	-40°C to +125°C
---	-----------------

⑥ Frequency Temperature Stability

W	$\pm 200 \times 10^{-6}$
---	--------------------------

⑦ Special

ZZ	Custom Specification
----	----------------------

Specifications

Items	Symbol	Specification	Units	Remarks
Frequency Range	f _{nom}	3200 to 20000	kHz	
Overtone Order	OT	Fundamental	—	
Frequency Tolerance	f _{tol}	± 100	$\times 10^{-6}$	@ 25°C
Frequency Temp. Characteristics	f _{tem}	± 200	$\times 10^{-6}$	ref.@ 25°C Over Operating Temp. Range
Motional Series Resistance	R1	Table 1	ohm	
Level of Drive	DL	Table 2	μ W	
Load Capacitance	CL	12	pF	
Operating Temp. Range	T _{use}	-40 to +125	°C	
Storage Temp. Range	T _{stg}	-40 to +125	°C	

* Please inquire about specifications other than the above.

Table1 Motional Series Resistances

Frequency Range	Motional Series Resistance	Units
3200 to 3499kHz	300	ohm
3500 to 4099kHz	150	
4100 to 4799kHz	120	
4800 to 5999kHz	100	
6000 to 11999kHz	90	
12000 to 13499kHz	70	
13500 to 20000kHz	50	

Table2 Level of Drive

Frequency Range	Level of Drive	Units
3200 to 15999kHz	10 (500 max.)	μ W
16000 to 20000kHz	10 (300 max.)	

Dimensions

(Unit : mm)

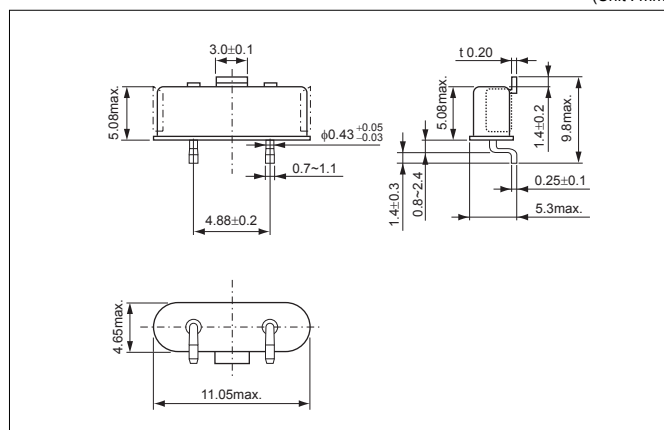

Recommended Land Pattern

(Unit : mm)

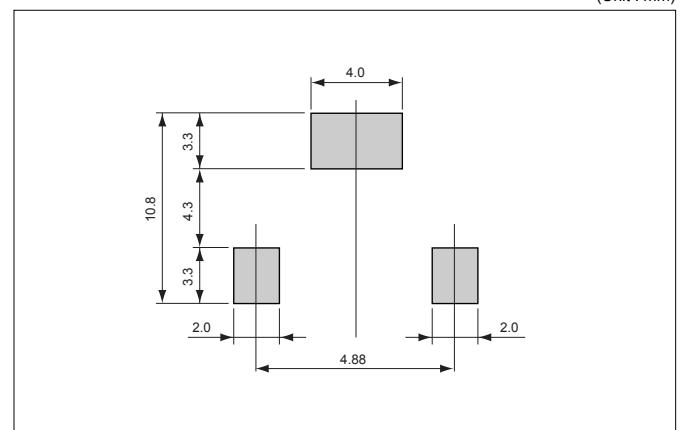

1. Shock & Drop • Vibration

Do not inflict excessive shock and mechanical vibration that exceeds the norm, such as hitting or mistakenly dropping, when transporting and mounting on a board. There are cases when pieces of crystal break, and pieces that are used become damaged, and become inoperable. When a shock or vibration that exceeds the norm has been inflicted, make sure to check the characteristics.

2. Cleaning

Since a crystal piece can be broken by resonance when a crystal device is cleaned by ultrasonic cleaning. Be careful when carrying out ultrasonic cleaning.

3. Soldering conditions

To maintain the product reliability, please follow recommended conditions.

Standard soldering iron conditions

	Crystal Units
Soldering iron	280°C to 340°C
Time	3+1/-0sec. max.

Reflow conditions (Example)

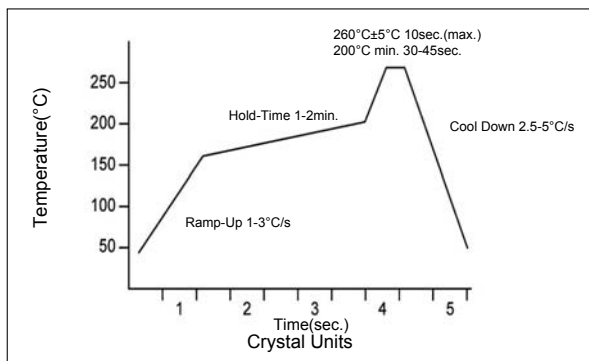

Recommended reflow Conditions vary depending upon products. Please check with the respective specification for details.

4. Mounting Precautions

Leaded Devices

The special glass, located where the lead of the retainer base comes out, is aligned with the coefficient of thermal expansion of the lead, If the glass is damaged and cracks appear, there may be cases in which performance deteriorates and it fails to operate.

Consequently, when making the device adhere closely and applying solder, align the gap of the hole of the board with the gap of the lead and insert without excessive force.

When making the device adhere closely to a through hole board and applying solder, be careful that the solder does not get into the metal part of the retainer base and cause a short. Putting in an insulation spacer is one more method of preventing a short circuit.

When the lead is mounted floating, fix it as far as possible so that contact with other parts and the breakage due to the fatigue, and the mechanical resonance of the lead will not occur.

When the lead is bent and used, do not bend the lead directly from the base, separate it 0.5mm or more and then bend it. When bending, before attaching to the board, fix the place where the lead comes out in advance and attach it after bending so that a crack does not occur in the glass part.

Surface Mount Devices

The lead of the device and the pattern of the board is soldered on the surface. Since extreme deformation of the board tears off the pattern, tears off the lead metal, cracks the solder and damages the sealed part of the device and there are cases in which performance deteriorates and operation fails, use it within the stipulated bending conditions. Due to the small cracks in the board resulting from mounting, please pay sufficient attention when attaching a device at the position where the warping of the board is great.

When using an automatic loading machine, as far as possible, select a type that has a small impact and use it while confirming that there is no damage.

Surface mount devices are NOT flow soldering compatible.

5. Storage Condition

Since the long hour high temperature and low temperature storage, as well as the storage at high humidity are causes of deterioration in frequency accuracy and solderability.

Parts should be stored in temperature range of -5 to +40°C, humidity 40 to 60% RH, and avoid direct sunlight. Then use within 6 months.

For Proper Use of Crystal Units

1. Characteristics of crystal units

The thickness of crystal vibrator of the AT cut crystal unit as described in the previous page differs depending on the overtone mode.

(1) Relationship between thickness of crystal blank and oscillation frequency

Cut angle/mode overtone	Frequency range (MHz)	Formula of thickness of crystal blank
AT/Fundamental mode	3.5 to 33	1.67/f
AT/3 rd O. T	33 to 100	5.01/f
AT/5 th O. T	100 to 150	8.35/f
AT/7 th O. T	150 to 200	11.69/f

f : Series resonance frequency (MHz)

In case of calculating the thickness of AT-cut 16MHz
 $t=1.67/16=0.104(\text{mm})$

(2) Examples of specifications for frequency-temperature characteristics

The frequency-temperature characteristics of the AT cut crystal unit are tertiary curves.

The diagram below shows examples of the tertiary curves that pass temperature range and frequency deviation specifications.

The range enclosed by the smaller rectangular satisfies the following specification:

$$\pm 10 \times 10^{-6} \text{ (-10 to 60: 25}^\circ\text{C)}$$

The range enclosed by the larger rectangular satisfies the following specification:

$$\pm 50 \times 10^{-6} \text{ (-20 to 70: 25}^\circ\text{C)}$$

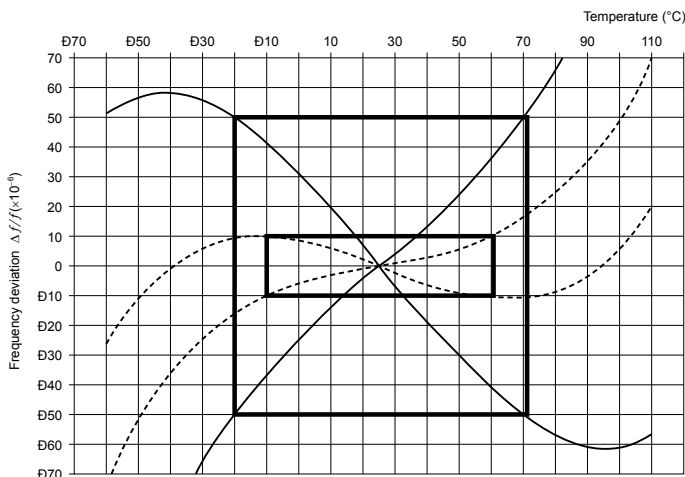

* These are examples. Required frequency-temperature specifications are determined through individual consultations.

(3) Equivalent electric circuit and equivalent constant of crystal unit

The following equivalent constants are used near the resonance frequency.

L_1 : Motional inductance in the equivalent electric circuit

C_1 : Motional capacitance in the equivalent electric circuit

R : Motional resistance in the equivalent electric circuit

C_0 : Parallel capacitance in the equivalent electric circuit

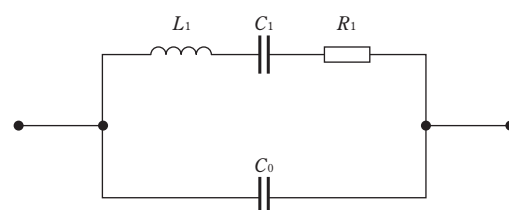

Equivalent electric circuit of a quartz crystal unit

(4) Items calculated by equivalent constants and load capacitance

f_s : Series resonance frequency	$f_s = \frac{1}{2\pi\sqrt{L_1 \cdot C_1}}$
f_p : Parallel resonance frequency	$f_p = \frac{1}{2\pi\sqrt{L_1 \frac{C_0 \cdot C_1}{C_0 + C_1}}}$
γ : Capacitance ratio	$\gamma = \frac{C_0}{C_1}$
f_L : Load resonance frequency	$f_L = f_s \left(\frac{C_1}{2 \cdot (C_0 + C_L)} + 1 \right)$
R_L : Load resistance	$R_L = R_1 \left(1 + \frac{C_0}{C_L} \right)^2$
C_L : Load capacitance	$C_L = \frac{C_1}{2} \cdot \frac{1}{(f_L/f_s)^2 - 1} - C_0$
Q : Quality factor	$Q = \frac{2\pi \cdot f_s \cdot L_1}{R_1} = \frac{1}{2\pi \cdot f_s \cdot C_1 \cdot R_1}$

The equation f_L shows that f_L varies as load capacitance C_L connected to the crystal unit changes and that f_L becomes larger as C_L becomes smaller.

The equation R_L shows the change in impedance with a load capacitance connected. The impedance of crystal unit becomes larger as C_L becomes smaller.

2. Oscillation circuit and crystal unit

(1) Equivalent circuit of oscillation circuit and oscillation conditions

A simplified equivalent circuit is shown below.

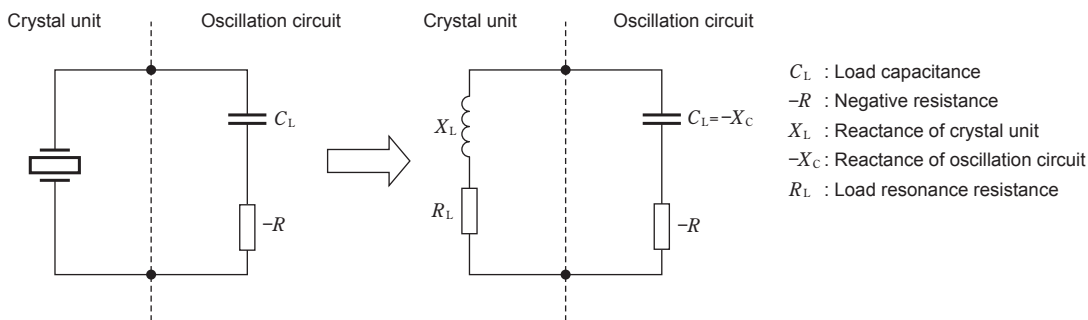



The oscillation start-up conditions are described as

$$R_L \leq |-R|$$

and in order to oscillate the crystal unit accurately, it must be designed such that the negative resistance of the oscillation circuit becomes bigger comparing with the resonance resistance value at the time of loading. This ratio is called oscillation margin degree M_{osc} and it is one of critical factors when designing the oscillation circuit and is described as below.

For oscillation circuit designing conditions, it is recommended that an oscillation circuit be designed using a negative resistance of a value five to ten times or more larger than R_L calculated from the resonance resistance specification value.

$$M_{osc} = |-R| / R_L \geq 5$$

In a steady oscillation state, the load resonance resistance is given as follows:

$$R_L = |-R|$$

The mutual conductance of the oscillation circuit decreases after the oscillation has started to continuously compensate for the power loss due to the load resonance resistance of the crystal unit, which continues oscillation.

The frequency condition is given as follows:

$$X_L = X_C, X_L - X_C = 0$$

As shown in the following figure, the reactance of the crystal unit varies to a value matching the load capacitance of the oscillation circuit $C_L = X_C$. Thus an oscillation frequency is determined.

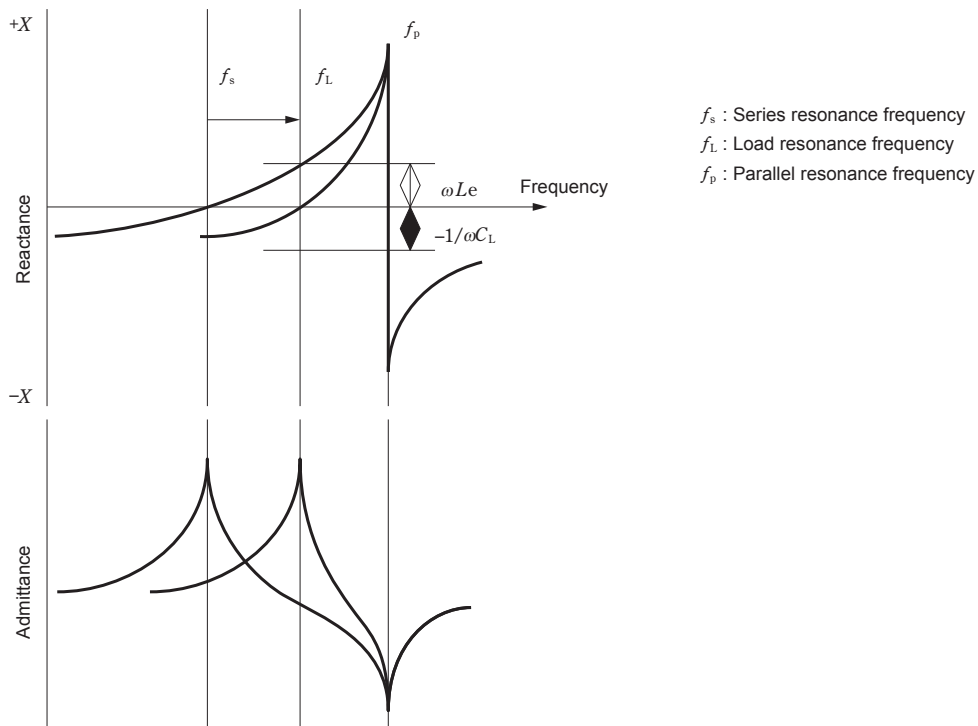

(2) Changes of load capacitance and oscillation frequency

As shown above, the series resonance frequency of the crystal unit changes with load capacitance C_L of the oscillation circuit. In the actual oscillation circuit, however, fine adjustments of oscillation frequencies are carried out by varying C_L by the trimmer capacitor or the like. The following figure shows an example of load capacity characteristics. The slope of the characteristics varies depending on the frequency, shape, the number of overtone mode, etc.

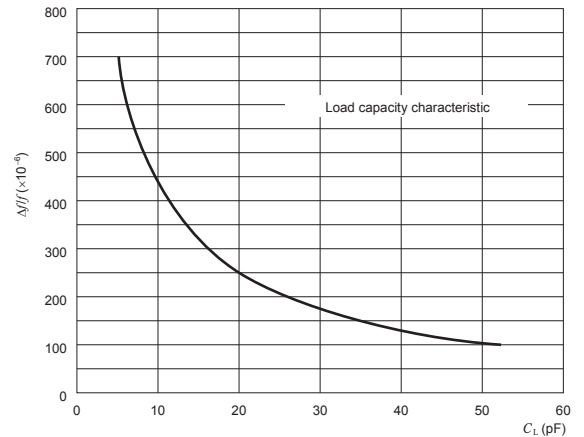

3. Crystal oscillation circuit

(1) CMOS fundamental crystal oscillation circuit

As shown above, the series resonance frequency of the crystal The figure on the right shows a standard CMOS inverter crystal oscillation circuit for oscillating crystal unit with fundamental mode. * R_x is an element to reduce excitation current of the crystal unit preventing frequency fluctuation, but R_x is not used in some cases.

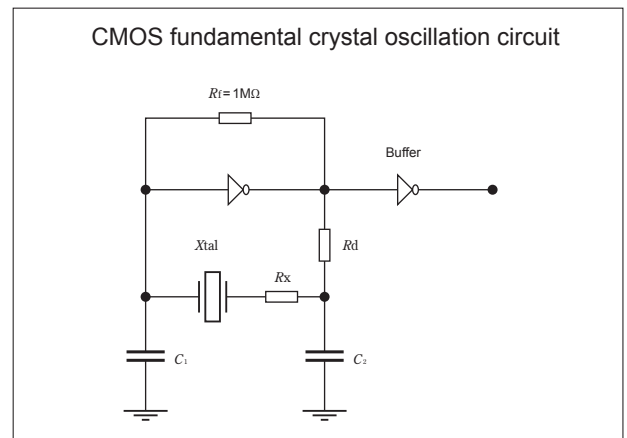

Characteristics of the circuit when load capacitances C_1 and C_2 are changed under the condition of $C_1 = C_2$ are shown in the figure on the right. It is not desirable that the excessive increase of the value of condenser leads to a decrease of the negative resistance resulting in increasing the possibility of oscillation failure.

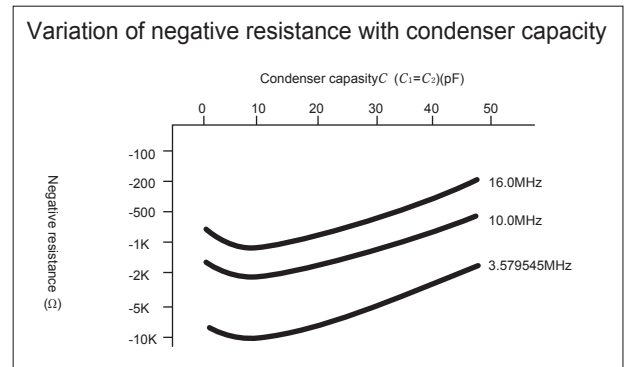

R_d mainly adjusts frequency characteristics of the negative resistance and is used to prevent oscillating by third Overtone mode. In case of a bigger circuit of the negative resistance, there is a case it is used to prevent the abnormal oscillation.

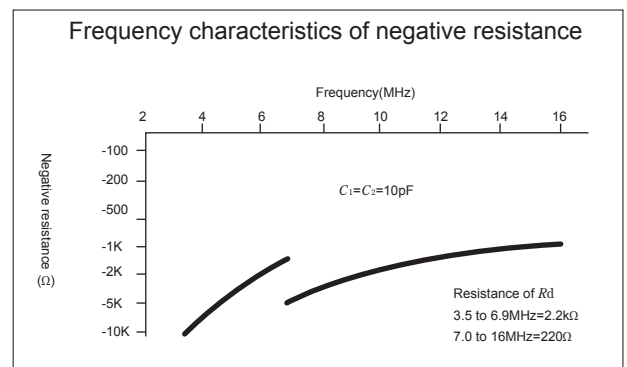

Selection of ICs and circuit constants by frequency bands

Frequency	3 to 4.9(MHz)	5 to 6.9(MHz)	7 to 9.9(MHz)	10 to 19.9(MHz)	20 to 30(MHz)
IC	TC4069UB TC4SU69F			TC74HCU04A TC7SU04F TC7WU04FU	TC74VHCU04 TC7SHU04F TC7WHU04FU
Rf	1MΩ				
Rd	*1	1500(Ω)	470(Ω)	0(Ω)	0(Ω)
Rx	*2	0 to 1500Ω			
C ₁ , C ₂	*3	6 to 22(pF)		6 to 15(pF)	6 to 15(pF)

*1: Necessary for preventing overtone oscillation and must be changed depending on the frequency band or the C₁ and C₂ values.
 *2: Used to reduce excitation current of the crystal unit. Necessary for stable operation of small-sized crystal units.
 *3: The optimum value differs with the values of load capacitance and Rd.

(2) CMOS overtone crystal oscillation circuit

This figure shows a standard CMOS inverter crystal oscillation circuit to oscillate a crystal unit using the overtone mode.

CMOS overtone crystal oscillation circuit

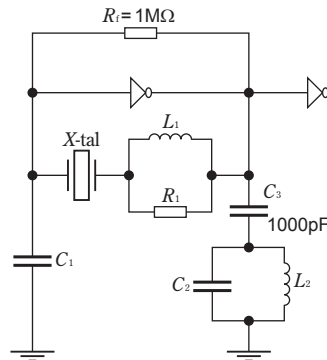

There are same cases when L₁ and R₁ are matched to the value of load capacitance.

(3) Selection of ICs and circuit constants by frequency bands

Frequency range	20 to 60(MHz)
IC	TC74VHCU04 TC7SHU04F TC7WHU04FU
C ₁	3 to 10pF
C ₂	10 to 22pF

(4) Method of selecting circuit constants and functions of elements

C₁ : Forms load capacitance of the circuit together with C₂, L₁ and L₂. A value of approx. 5pF is used.

C₂ : Forms load capacitance of the circuit together with C₁, L₁ and L₂. Prevents fundamental wave oscillation. Shall be selected so that C₂ comes between the third overtone frequency at which resonance frequency with L₂ is to make oscillation and 1/3 of the third overtone frequency. A value of 10 to 22pF is used.

C₃ : A bypass capacitor

L₁ : A coil to adjust load capacitance of the oscillation circuit to a value near the series. A value of several μH is used.

L₂ : Forms load capacitance of the circuit together with C₁, C₂ and L₁. Prevents fundamental wave oscillation. Shall be selected so that L₂ comes between the third overtone frequency at which resonance frequency with C₂ is to make oscillation and 1/3 of the third overtone frequency. A value of 10 to 22pF is used.

R₁ : A Q dump resistor for L₁. As an element for preventing self-excited oscillation, A value of several kΩ to several tens of kΩ is used.

* L₁ and R₁ might not be used.

(5) Method of checking oscillation circuit

- ① Some ICs have a low upper-limit value of usable frequency, so refer to individual IC catalog to make sure that the IC can oscillate a crystal unit with an adequate negative resistance.
- ② The following figure shows an example of a CMOS oscillation circuit. Check resistance R_{sup} is connected in series with the crystal unit to check the negative resistance. Use 3 to 22pF for C_1 and C_2 , and see the table below for values of check resistance.

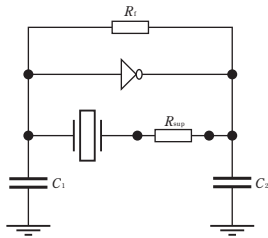

Frequency range	Values of check resistance
3.5 to 4.5MHz	1.5kΩ
4.6 to 6.0MHz	1.0kΩ
6.1 to 10.0MHz	800Ω
10.1 to 14.0MHz	500Ω
14.1 to 20.0MHz	400Ω

- ③ Using a spectrum analyzer or oscilloscope, check that every oscillation is normally activated while turning the power on and off several times. For oscillation circuits with no power regulator ICs, carefully check changes in the negative resistance against supply voltage and in frequencies.
- ④ When oscillation is normal, remove the check resistance before using the crystal circuit.
- ⑤ If oscillation is unstable or is not generated, gradually decrease the values of C_1 and C_2 until normal oscillation is obtained.
- ⑥ If normal oscillation cannot be generated near 10MHz or near 20MHz, replace the IC with a new one suitable for higher frequencies.

(6) Load capacitance and oscillation frequency of transistor/fundamental crystal oscillation circuit

Viewed from the connection terminals of a crystal unit, the load capacitance C_L of an oscillation circuit is generally comprised of C_1 , C_t , C_2 , and C_3 if stray capacitance of the circuit and the capacitance between base and emitter of the transistor are ignored. Since trimmer capacitor is adjusted to $C_T = \text{MIN. to MAX.}$ for zero adjustment of the oscillation frequency, the value of C_L at this time can be obtained from the following equation.

$$C_{L\text{MIN.}} = \left(\frac{1}{C_1 + C_T} + \frac{1}{C_2} + \frac{1}{C_3} \right)^{-1} \text{ to } C_{L\text{MAX.}} = \left(\frac{1}{C_1 + C_T} + \frac{1}{C_2} + \frac{1}{C_3} \right)^{-1}$$

When these calculation results are substituted for the following equation for load resonance frequency, the oscillation frequency can be obtained.

$$f_L = f_s \left(\frac{C_1}{2 \cdot (C_0 + C_L)} + 1 \right)$$

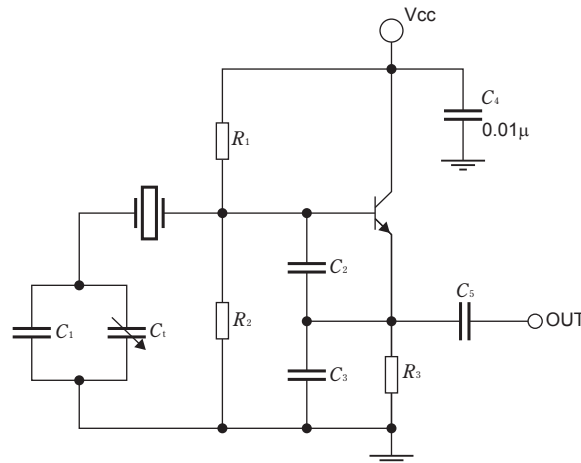

Select each circuit constant so that the adjustment ranges of upper and lower frequencies of this circuit are even on the basis of the frequency of a single crystal unit measured using a specified load capacity, and that the margin of ± 8 to 10×10^{-6} of the room temperature deviation of the crystal unit can be reserved.

To prevent the decrease in the negative resistance, always connect the crystal unit to the base of the transistor. For transistors used for oscillation circuits, h_{fe} and f_T are important.

To obtain the large negative resistance with small current consumption, select a transistor for high frequency amplification with h_{fe} of over 250 and f_T of 1GHz or more.

(7) Transistor third overtone oscillation circuit

- ① The resonance circuit comprised of L_2 and C_3 is required on the emitter side for preventing fundamental mode crystal oscillation. Set the resonance frequency to a value higher than the intermediate between fundamental wave frequency and third overtone frequency.
- ② Use L_1 , referred to as an elongation coil, to connect the load capacitance of the oscillation circuit in series. R_1 prevents self-excited oscillation by L_1 . Since it is difficult in general to design the oscillation circuit having adequate negative resistance in the overtone oscillation frequency band, there are no other effective means of obtaining adequate oscillation margin except for preventing the increase of load resonance resistance R_L of the crystal unit.



R_L in the equation of load resonance resistance can be made equal to R_s by connecting C_L in series, or making it infinite, which prevents increase in the load resonance resistance.

$$R_L = R_1 \left(1 + \frac{C_0}{C_L} \right)^2$$

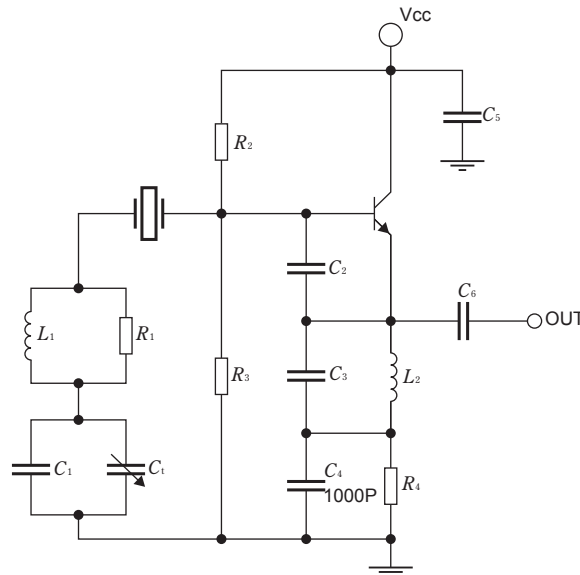

To prevent decrease in the negative resistance, connect the crystal unit to the base of the transistor as in the fundamental mode crystal oscillation circuit. To use the crystal circuit for both oscillation and multiplication, connect a parallel resonance circuit having multiplication frequency as resonance frequency to the collector of the transistor.

When selecting circuit constants for zero adjustment range by trimmer capacitor, set the constants to values obtained by adding approx. ± 12 to 15×10^{-6} to the room temperature deviation of the crystal unit, centering the value obtained by measuring the crystal unit with load capacitances in series. (When the room temperature deviation specification of the crystal unit is $\pm 10 \times 10^{-6}$)

(8) Excitation power of oscillation circuit

Normal operation of crystal units is not assured when excitation power is raised. The allowable excitation power varies depending on the shape of the crystal unit or the stability of targeted frequency. When highly accurate oscillation is required, however, it is recommended to use an oscillation circuit with an excitation power of 5 to 50 μ W or less. For other cases, refer to individual relevant crystal units on the pages of the catalog.

(9) Precautions for designing printed circuit board

Be sure to design printed circuit board patterns that connect a crystal unit with other oscillation elements so that the lengths of such patterns become shortest possible to prevent deterioration of characteristics due to stray capacitances and wiring inductance. For multi-layer circuit boards, it is important not to wire the ground and other signal patterns right beneath the oscillation circuit.

Tape & Reel Specifications

Crystal Units

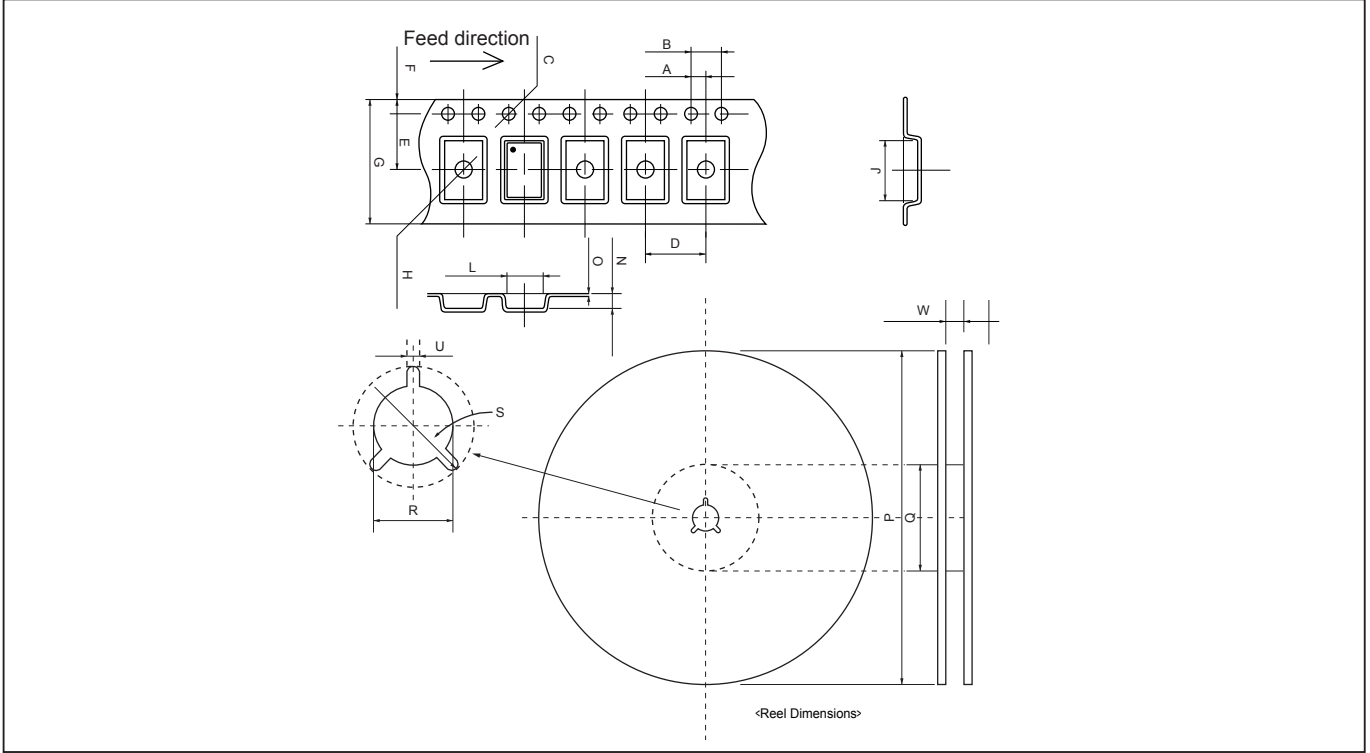

		CX2520SB (CX-2520SB)	CX3225SB (CX-101F)	CX4025SB (CX-4025S)	CX5032SB (CX-96F)	CX5032GB (CX-53F)	CX8045GB (CX-8045G) CX8045JA (CX-17F)	CXZ49FFA (CX-49F)	CX855GA (CX-5FW) CXB855GB (CX-5FD)	CXZ9LPA (CX-49L)
T A P E	A	2.0±0.05	2.0±0.05	2.0±0.1	2.0±0.1	2.0±0.1	2.0±0.1	2.0±0.1	2.0±0.1	2.0±0.1
	B	4.0±0.1	4.0±0.1	4.0±0.1	4.0±0.1	4.0±0.1	4.0±0.1	4.0±0.1	4.0±0.1	4.0±0.1
	C	φ1.55±0.05	φ1.55±0.05	φ1.55±0.05	φ1.5±0.1	φ1.55±0.1	φ1.5±0.1	φ1.55±0.05	φ1.55±0.05	φ1.5±0.1
	D	4.0±0.05	4.0±0.05	4.0±0.1	8.0±0.1	8.0±0.1	8.0±0.1	8.0±0.1	12.0±0.1	16.0±0.1
	E	3.5±0.05	3.5±0.05	5.5±0.1	5.5±0.1	5.5±0.1	7.5±0.1	11.5±0.1	11.5±0.1	11.5±0.1
	F	1.75±0.1	1.75±0.1	1.75±0.1	1.75±0.1	1.75±0.1	1.75±0.1	1.75±0.1	1.75±0.1	1.75±0.1
	G	8.0±0.2	8.0±0.2	12.0±0.3	12.0±0.3	12.0±0.2	16.0±0.3	24.0±0.3	24.0±0.3	24.0±0.3
	H	φ1.05±0.1	φ1.05±0.1	φ1.05±0.1	φ1.5±0.1	φ1.55±0.1	φ1.55±0.05	φ2.05±0.05	φ2.05±0.05	φ2.2±0.1
	J	3.5±0.1	3.5±0.1	4.2±0.1	5.5±0.1	5.4±0.1	8.4±0.1	11.5±0.1	12.2±0.1	—
	L	2.8±0.1	2.8±0.1	2.7±0.1	3.7±0.1	3.6±0.1	4.9±0.1	5.4±0.1	5.85±0.1	—
	N	0.85±0.1	0.85±0.1	0.95±0.05	1.4±0.1	1.7±0.1	2.1±0.1	5.5±0.1	2.8±0.1	6.5±0.1
O	0.25±0.05	0.25±0.05	0.2±0.05	0.3±0.05	0.25±0.05	0.3±0.05	0.3±0.05	0.3±0.05	0.5±0.05	
R E E L	P	φ180+0/-3	φ180+0/-3	φ180+0/-3	φ330±2/φ178±2	φ330±2/φ254±2	φ330±2/φ254±2	φ330±2	φ330±2	φ330±2
	Q	φ60+1/-0	φ60+1/-0	φ60+1/-0	φ80±2/φ100±1	φ100±1	φ80±1	φ100±1	φ100±1	φ100±1
	R	φ13±0.2	φ13±0.2	φ13±0.2	φ13±0.2	φ13±0.2	φ13±0.2	φ13±0.5	φ13±0.5	φ13±0.5
	S	φ21±0.8	φ21±0.8	φ21±0.8	φ21±0.8	φ21±0.8	φ21±0.8	φ21±0.5	φ21±0.5	—
	U	2.0±0.5	2.0±0.5	2.0±0.5	2.0±0.5	2.0±0.5	2.0±0.5	2.0±0.2	2.0±0.5	—
W	9±1	9±1	13±1	13.5+1/-0.5	13.4+2/-0	16.0+2/-0	25.5±0.5	24.4+2/-0	25.5+1/-0.5	
Qty		3000/1000	3000/1000	3000/1000	5000/1000	3000/1000	3000/1000	1000	1000	600