

MC10ELT24, MC100ELT24

5V TTL to Differential ECL Translator

Description

The MC10ELT/100ELT24 is a TTL to differential ECL translator. Because ECL levels are used a +5 V, -5.2 V (or -4.5 V) and ground are required. The small outline 8-lead package and the single gate of the ELT24 makes it ideal for those applications where space, performance and low power are at a premium.

The 100 Series contains temperature compensation.

Features

- 0.8 ns t_{PHL} , 0.95 ns t_{PLH} Typical Propagation Delay
- PNP TTL Inputs for Minimal Loading
- Flow Through Pinouts
- Operating Range: $V_{CC} = 4.5\text{ V to }5.5\text{ V}$; $V_{EE} = -4.2\text{ V to }-5.5\text{ V}$ with $GND = 0\text{ V}$
- Pb-Free Packages are Available



ON Semiconductor®

<http://onsemi.com>

MARKING DIAGRAMS*



**SOIC-8
D SUFFIX
CASE 751**

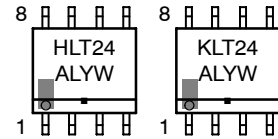

**TSSOP-8
DT SUFFIX
CASE 948R**

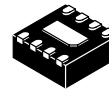
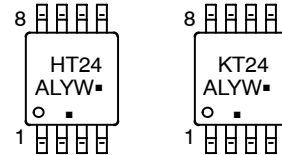

**DFN8
MN SUFFIX
CASE 506AA**

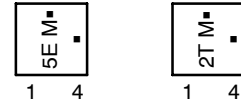

H = MC10	A = Assembly Location
K = MC100	L = Wafer Lot
5E = MC10	Y = Year
2T = MC100	W = Work Week
M = Date Code	▪ = Pb-Free Package

(Note: Microdot may be in either location)

*For additional marking information, refer to Application Note AND8002/D.

ORDERING INFORMATION

See detailed ordering and shipping information in the package dimensions section on page 5 of this data sheet.

MC10ELT24, MC100ELT24

[查询"MC10ELT24D"供应商](#)

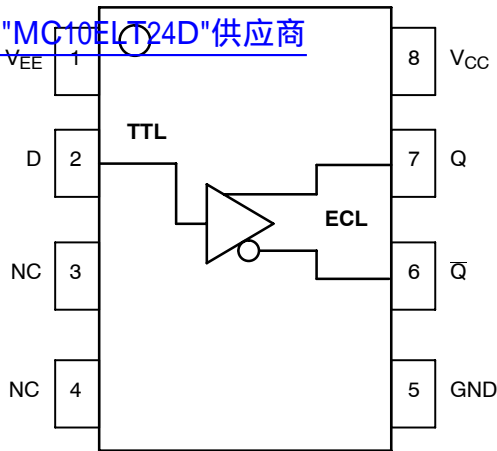

Table 1. PIN DESCRIPTION

Pin	Function
Q, \bar{Q}	ECL Differential Outputs*
D	TTL Input
V _{CC}	Positive Supply
V _{EE}	Negative Supply
GND	Ground
NC	No Connect
EP	Exposed pad must be connected to a sufficient thermal conduit. Electrically connect to the most negative supply or leave floating open.

*Output state undetermined when inputs are open.

Figure 1. 8-Lead Pinout (Top View) and Logic Diagram

Table 2. ATTRIBUTES

Characteristics	Value	
Internal Input Pulldown Resistor	N/A	
Internal Input Pullup Resistor	N/A	
ESD Protection	Human Body Model	> 4 kV
	Machine Model	> 200 V
Moisture Sensitivity, Indefinite Time Out of Drypack (Note 1)	Pb Pkg	Pb-Free Pkg
	SOIC-8	Level 1
	TSSOP-8	Level 3
	DFN8	Level 1
Flammability Rating	Oxygen Index: 28 to 34	
	UL 94 V-0 @ 0.125 in	
Transistor Count	51 Devices	
Meets or exceeds JEDEC Spec EIA/JESD78 IC Latchup Test		

1. For additional information, see Application Note AND8003/D.

MC10ELT24, MC100ELT24

Table 3. MAXIMUM RATINGS

Symbol	Parameter	Condition 1	Condition 2	Rating	Unit
V _{CC}	Positive Power Supply	GND = 0 V	V _{EE} = -5.0 V	7	V
V _{EE}	Negative Power Supply	GND = 0 V	V _{CC} = +5.0 V	-8	V
V _{IN}	Input Voltage	GND = 0 V	V _I ≤ V _{CC}	0 to V _{CC}	V
I _{out}	Output Current	Continuous Surge		50 100	mA mA
T _A	Operating Temperature Range			-40 to +85	°C
T _{stg}	Storage Temperature Range			-65 to +150	°C
θ _{JA}	Thermal Resistance (Junction-to-Ambient)	0 lfpm 500 lfpm	SO-8 SO-8	190 130	°C/W °C/W
θ _{JC}	Thermal Resistance (Junction-to-Case)	Standard Board	SO-8	41 to 44	°C/W
θ _{JA}	Thermal Resistance (Junction-to-Ambient)	0 lfpm 500 lfpm	TSSOP-8 TSSOP-8	185 140	°C/W °C/W
θ _{JC}	Thermal Resistance (Junction-to-Case)	Standard Board	TSSOP-8	41 to 44 ± 5%	°C/W
θ _{JA}	Thermal Resistance (Junction-to-Ambient)	0 lfpm 500 lfpm	DFN8 DFN8	129 84	°C/W °C/W
T _{sol}	Wave Solder	Pb Pb-Free	<2 to 3 sec @ 248°C <2 to 3 sec @ 260°C	265 265	°C

Stresses exceeding Maximum Ratings may damage the device. Maximum Ratings are stress ratings only. Functional operation above the Recommended Operating Conditions is not implied. Extended exposure to stresses above the Recommended Operating Conditions may affect device reliability.

Table 4. 10ELT SERIES NECL OUTPUT DC CHARACTERISTICS V_{CC} = 5.0 V; V_{EE} = -5.0 V; GND = 0 V (Note 2)

Symbol	Characteristic	-40°C			25°C			85°C			Unit
		Min	Typ	Max	Min	Typ	Max	Min	Typ	Max	
I _{CC}	V _{CC} Power Supply Current			7.0		4.5	7.0			7.0	mA
I _{EE}	Power Supply Current			18		12.5	18			18	mA
V _{OH}	Output HIGH Voltage (Note 3)	-1080	-990	-890	-980	-895	-810	-910	-815	-720	mV
V _{OL}	Output LOW Voltage (Note 3)	-1950	-1800	-1650	-1950	-1790	-1630	-1950	-1773	-1595	mV

NOTE: Device will meet the specifications after thermal equilibrium has been established when mounted in a test socket or printed circuit board with maintained transverse airflow greater than 500 lfpm. Electrical parameters are guaranteed only over the declared operating temperature range. Functional operation of the device exceeding these conditions is not implied. Device specification limit values are applied individually under normal operating conditions and not valid simultaneously.

- Output parameters vary 1:1 with GND. V_{CC} can vary 4.5 V / 5.5 V. V_{EE} can vary -4.2 V / -5.5 V.
- Outputs are terminated through a 50 Ω resistor to GND - 2 V.

Table 5. 100ELT SERIES NECL OUTPUT DC CHARACTERISTICS V_{CC} = 5.0 V; V_{EE} = -5.0 V; GND = 0 V (Note 4)

Symbol	Characteristic	-40°C			25°C			85°C			Unit
		Min	Typ	Max	Min	Typ	Max	Min	Typ	Max	
I _{CC}	V _{CC} Power Supply Current			7.0		4.5	7.0			7.0	mA
I _{EE}	Power Supply Current			18		12.5	18			18	mA
V _{OH}	Output HIGH Voltage (Note 5)	-1085	-1005	-880	-1025	-955	-880	-1025	-955	-880	mV
V _{OL}	Output LOW Voltage (Note 5)	-1830	-1695	-1555	-1810	-1705	-1620	-1810	-1705	-1620	mV

NOTE: Device will meet the specifications after thermal equilibrium has been established when mounted in a test socket or printed circuit board with maintained transverse airflow greater than 500 lfpm. Electrical parameters are guaranteed only over the declared operating temperature range. Functional operation of the device exceeding these conditions is not implied. Device specification limit values are applied individually under normal operating conditions and not valid simultaneously.

- Output parameters vary 1:1 with GND. V_{CC} can vary 4.5 V / 5.5 V. V_{EE} can vary -4.2 V / -5.5 V.
- Outputs are terminated through a 50 Ω resistor to GND - 2 V.

MC10ELT24, MC100ELT24

Table 6. TTL INPUT DC CHARACTERISTICS $V_{CC} = 4.5\text{ V to }5.5\text{ V}$; $V_{EE} = -4.2\text{ V to }-5.5\text{ V}$; $GND = 0.0\text{ V}$; $T_A = -40^\circ\text{C to }+85^\circ\text{C}$

Symbol	Characteristic	Condition	Min	Typ	Max	Unit
I_{IH}	Input HIGH Current	$V_{IN} = 2.7\text{ V}$			20	μA
I_{IHH}	Input HIGH Current	$V_{IN} = 7.0\text{ V}$			100	μA
I_{IL}	Input LOW Current	$V_{IN} = 0.5\text{ V}$			-0.6	mA
V_{IK}	Input Clamp Diode Voltage	$I_{IN} = -18\text{ mA}$			-1.2	V
V_{IH}	Input HIGH Voltage		2.0			V
V_{IL}	Input LOW Voltage				0.8	V

NOTE: Device will meet the specifications after thermal equilibrium has been established when mounted in a test socket or printed circuit board with maintained transverse airflow greater than 500 lpm. Electrical parameters are guaranteed only over the declared operating temperature range. Functional operation of the device exceeding these conditions is not implied. Device specification limit values are applied individually under normal operating conditions and not valid simultaneously.

Table 7. AC CHARACTERISTICS $V_{CC} = 4.5\text{ V to }5.5\text{ V}$; $V_{EE} = -4.2\text{ V to }-5.5\text{ V}$; $GND = 0.0\text{ V}$

Symbol	Characteristic	-40°C			25°C			85°C			Unit
		Min	Typ	Max	Min	Typ	Max	Min	Typ	Max	
f_{max}	Maximum Toggle Frequency					400					MHz
t_{PLH}	Propagation Delay (Note 6) 1.5 V to 50%	0.5		2.0	0.5	0.95	2.0	0.5		2.0	ns
t_{PHL}	Propagation Delay (Note 6) 1.5 V to 50%	0.5		2.0	0.5	0.8	2.0	0.5		2.0	ns
t_{JITTER}	Random Clock Jitter (RMS)					2.5					ps
t_r/t_f	Output Rise/Fall Time (20–80%)	0.25		1.25	0.25		1.25	0.25		1.25	ns

NOTE: Device will meet the specifications after thermal equilibrium has been established when mounted in a test socket or printed circuit board with maintained transverse airflow greater than 500 lpm. Electrical parameters are guaranteed only over the declared operating temperature range. Functional operation of the device exceeding these conditions is not implied. Device specification limit values are applied individually under normal operating conditions and not valid simultaneously.

6. Specifications for standard TTL input signal.

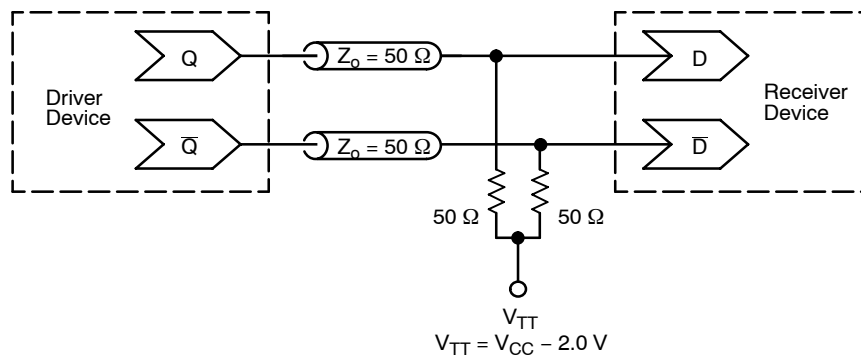

Figure 2. Typical Termination for Output Driver and Device Evaluation
(See Application Note AND8020/D – Termination of ECL Logic Devices.)

MC10ELT24, MC100ELT24

ORDERING INFORMATION

Device	Package	Shipping [†]
MC10ELT24D	SOIC-8	98 Units / Rail
MC10ELT24DG	SOIC-8 (Pb-Free)	98 Units / Rail
MC10ELT24DR2	SOIC-8	2500 / Tape & Reel
MC10ELT24DR2G	SOIC-8 (Pb-Free)	2500 / Tape & Reel
MC10ELT24DT	TSSOP-8	100 Units / Rail
MC10ELT24DTG	TSSOP-8 (Pb-Free)	100 Units / Rail
MC10ELT24DTR2	TSSOP-8	2500 / Tape & Reel
MC10ELT24DTR2G	TSSOP-8 (Pb-Free)	2500 / Tape & Reel
MC10ELT24MNR4	DFN8	1000 / Tape & Reel
MC10ELT24MNR4G	DFN8 (Pb-Free)	1000 / Tape & Reel
MC100ELT24D	SOIC-8	98 Units / Rail
MC100ELT24DG	SOIC-8 (Pb-Free)	98 Units / Rail
MC100ELT24DR2	SOIC-8	2500 / Tape & Reel
MC100ELT24DR2G	SOIC-8 (Pb-Free)	2500 / Tape & Reel
MC100ELT24DT	TSSOP-8	100 Units / Rail
MC100ELT24DTG	TSSOP-8 (Pb-Free)	100 Units / Rail
MC100ELT24DTR2	TSSOP-8	2500 / Tape & Reel
MC100ELT24DTR2G	TSSOP-8 (Pb-Free)	2500 / Tape & Reel
MC100ELT24MNR4	DFN8	1000 / Tape & Reel
MC100ELT24MNR4G	DFN8 (Pb-Free)	1000 / Tape & Reel

[†]For information on tape and reel specifications, including part orientation and tape sizes, please refer to our Tape and Reel Packaging Specifications Brochure, BRD8011/D.

Resource Reference of Application Notes

- AN1405/D** - ECL Clock Distribution Techniques
- AN1406/D** - Designing with PECL (ECL at +5.0 V)
- AN1503/D** - ECLinPS™ I/O SPICE Modeling Kit
- AN1504/D** - Metastability and the ECLinPS Family
- AN1568/D** - Interfacing Between LVDS and ECL
- AN1672/D** - The ECL Translator Guide
- AND8001/D** - Odd Number Counters Design
- AND8002/D** - Marking and Date Codes
- AND8020/D** - Termination of ECL Logic Devices
- AND8066/D** - Interfacing with ECLinPS
- AND8090/D** - AC Characteristics of ECL Devices

MC10ELT24, MC100ELT24

[查询"MC10ELT24D"供应商](#)

PACKAGE DIMENSIONS

SOIC-8 NB
CASE 751-07
ISSUE AH

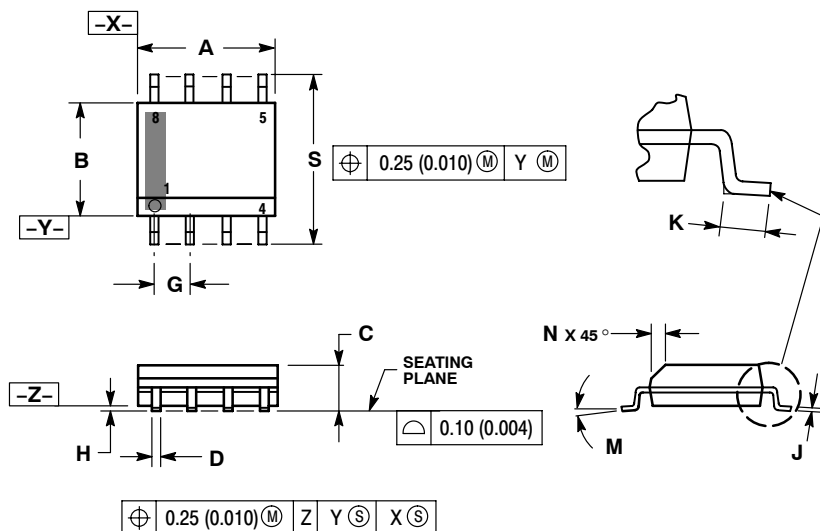

NOTES:

1. DIMENSIONING AND TOLERANCING PER ANSI Y14.5M, 1982.
2. CONTROLLING DIMENSION: MILLIMETER.
3. DIMENSION A AND B DO NOT INCLUDE MOLD PROTRUSION.
4. MAXIMUM MOLD PROTRUSION 0.15 (0.006) PER SIDE.
5. DIMENSION D DOES NOT INCLUDE DAMBAR PROTRUSION. ALLOWABLE DAMBAR PROTRUSION SHALL BE 0.127 (0.005) TOTAL IN EXCESS OF THE D DIMENSION AT MAXIMUM MATERIAL CONDITION.
6. 751-01 THRU 751-06 ARE OBSOLETE. NEW STANDARD IS 751-07.

DIM	MILLIMETERS		INCHES	
	MIN	MAX	MIN	MAX
A	4.80	5.00	0.189	0.197
B	3.80	4.00	0.150	0.157
C	1.35	1.75	0.053	0.069
D	0.33	0.51	0.013	0.020
G	1.27 BSC		0.050 BSC	
H	0.10	0.25	0.004	0.010
J	0.19	0.25	0.007	0.010
K	0.40	1.27	0.016	0.050
M	0 °	8 °	0 °	8 °
N	0.25	0.50	0.010	0.020
S	5.80	6.20	0.228	0.244

SOLDERING FOOTPRINT*

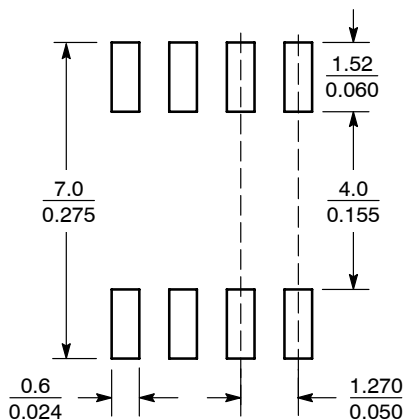

SCALE 6:1 (mm/inches)

*For additional information on our Pb-Free strategy and soldering details, please download the ON Semiconductor Soldering and Mounting Techniques Reference Manual, SOLDERRM/D.

MC10ELT24, MC100ELT24

[查询"MC10ELT24D"供应商](#)

PACKAGE DIMENSIONS

TSSOP-8
DT SUFFIX
 PLASTIC TSSOP PACKAGE
 CASE 948R-02
 ISSUE A

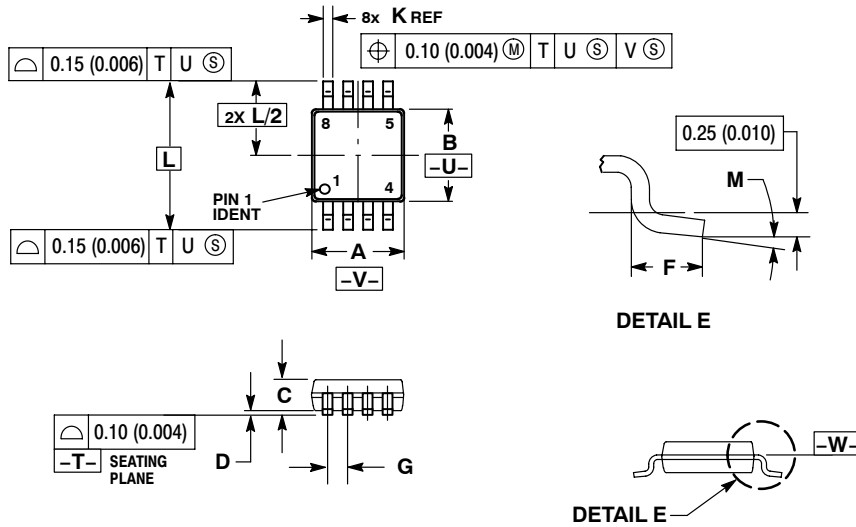

NOTES:

1. DIMENSIONING AND TOLERANCING PER ANSI Y14.5M, 1982.
2. CONTROLLING DIMENSION: MILLIMETER.
3. DIMENSION A DOES NOT INCLUDE MOLD FLASH, PROTRUSIONS OR GATE BURRS. MOLD FLASH OR GATE BURRS SHALL NOT EXCEED 0.15 (0.006) PER SIDE.
4. DIMENSION B DOES NOT INCLUDE INTERLEAD FLASH OR PROTRUSION. INTERLEAD FLASH OR PROTRUSION SHALL NOT EXCEED 0.25 (0.010) PER SIDE.
5. TERMINAL NUMBERS ARE SHOWN FOR REFERENCE ONLY.
6. DIMENSION A AND B ARE TO BE DETERMINED AT DATUM PLANE -W-.

DIM	MILLIMETERS		INCHES	
	MIN	MAX	MIN	MAX
A	2.90	3.10	0.114	0.122
B	2.90	3.10	0.114	0.122
C	0.80	1.10	0.031	0.043
D	0.05	0.15	0.002	0.006
F	0.40	0.70	0.016	0.028
G	0.65 BSC		0.026 BSC	
K	0.25	0.40	0.010	0.016
L	4.90 BSC		0.193 BSC	
M	0°	6°	0°	6°

MC10ELT24, MC100ELT24

[查询"MC10ELT24D"供应商](#)

PACKAGE DIMENSIONS

DFN8
CASE 506AA-01
ISSUE D

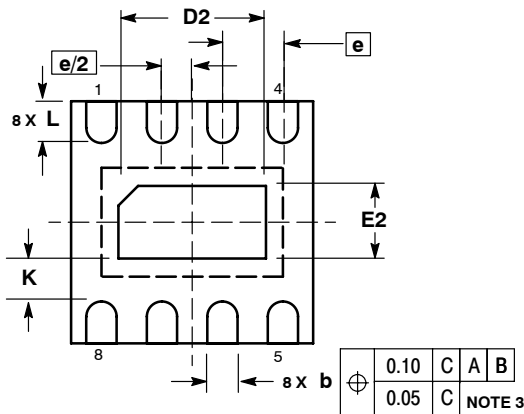
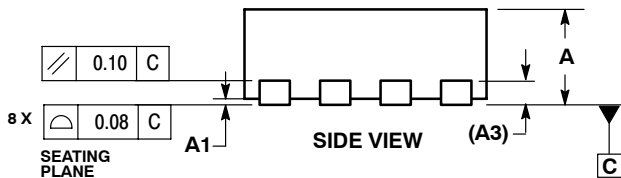
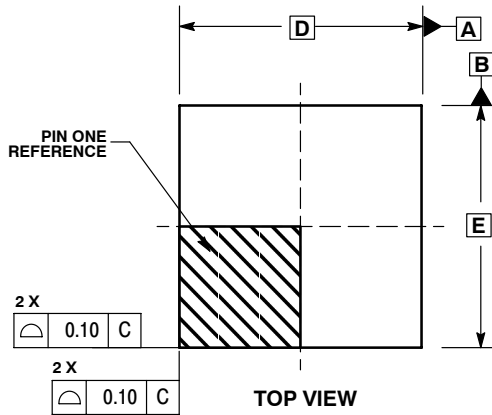

NOTES:

1. DIMENSIONING AND TOLERANCING PER ASME Y14.5M, 1994 .
2. CONTROLLING DIMENSION: MILLIMETERS.
3. DIMENSION b APPLIES TO PLATED TERMINAL AND IS MEASURED BETWEEN 0.25 AND 0.30 MM FROM TERMINAL.
4. COPLANARITY APPLIES TO THE EXPOSED PAD AS WELL AS THE TERMINALS.

DIM	MILLIMETERS	
	MIN	MAX
A	0.80	1.00
A1	0.00	0.05
A3	0.20 REF	
b	0.20	0.30
D	2.00 BSC	
D2	1.10	1.30
E	2.00 BSC	
E2	0.70	0.90
e	0.50 BSC	
K	0.20	---
L	0.25	0.35

ECLinPS is a trademark of Semiconductor Components Industries, LLC (SCILLC).

ON Semiconductor and are registered trademarks of Semiconductor Components Industries, LLC (SCILLC). SCILLC reserves the right to make changes without further notice to any products herein. SCILLC makes no warranty, representation or guarantee regarding the suitability of its products for any particular purpose, nor does SCILLC assume any liability arising out of the application or use of any product or circuit, and specifically disclaims any and all liability, including without limitation special, consequential or incidental damages. "Typical" parameters which may be provided in SCILLC data sheets and/or specifications can and do vary in different applications and actual performance may vary over time. All operating parameters, including "Typicals" must be validated for each customer application by customer's technical experts. SCILLC does not convey any license under its patent rights nor the rights of others. SCILLC products are not designed, intended, or authorized for use as components in systems intended for surgical implant into the body, or other applications intended to support or sustain life, or for any other application in which the failure of the SCILLC product could create a situation where personal injury or death may occur. Should Buyer purchase or use SCILLC products for any such unintended or unauthorized application, Buyer shall indemnify and hold SCILLC and its officers, employees, subsidiaries, affiliates, and distributors harmless against all claims, costs, damages, and expenses, and reasonable attorney fees arising out of, directly or indirectly, any claim of personal injury or death associated with such unintended or unauthorized use, even if such claim alleges that SCILLC was negligent regarding the design or manufacture of the part. SCILLC is an Equal Opportunity/Affirmative Action Employer. This literature is subject to all applicable copyright laws and is not for resale in any manner.

PUBLICATION ORDERING INFORMATION

LITERATURE FULFILLMENT:
Literature Distribution Center for ON Semiconductor
P.O. Box 5163, Denver, Colorado 80217 USA
Phone: 303-675-2175 or 800-344-3860 Toll Free USA/Canada
Fax: 303-675-2176 or 800-344-3867 Toll Free USA/Canada
Email: orderlit@onsemi.com

N. American Technical Support: 800-282-9855 Toll Free
USA/Canada
Europe, Middle East and Africa Technical Support:
Phone: 421 33 790 2910
Japan Customer Focus Center
Phone: 81-3-5773-3850

ON Semiconductor Website: www.onsemi.com
Order Literature: <http://www.onsemi.com/orderlit>
For additional information, please contact your local Sales Representative