



1. SCOPE

查询"5962-90686/QGA"供应商

This drawing documents two product assurance class levels consisting of high reliability (device classes Q and M) and space application (device class V). A choice of case outlines and lead finishes are available and are reflected in the Part or Identifying Number (PIN). When available, a choice of Radiation Hardness Assurance (RHA) levels are reflected in the PIN.

1.2 PIN. The PIN is as shown in the following example:

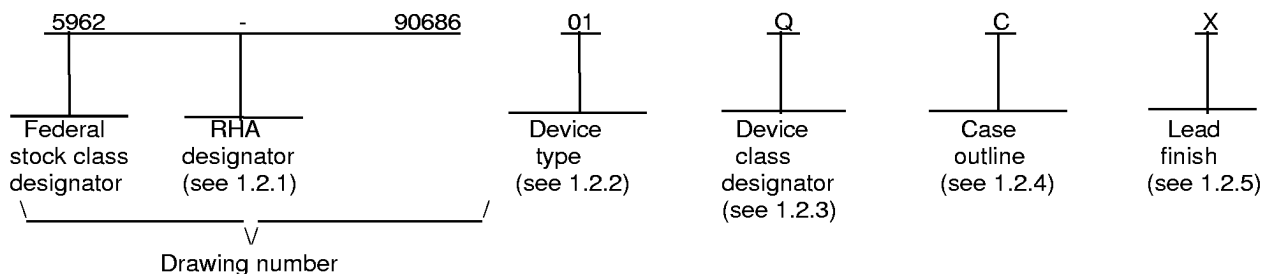

1.2.1 RHA designator. Device classes Q and V RHA marked devices meet the MIL-PRF-38535 specified RHA levels and are marked with the appropriate RHA designator. Device class M RHA marked devices meet the MIL-PRF-38535, appendix A specified RHA levels and are marked with the appropriate RHA designator. A dash (-) indicates a non-RHA device.

1.2.2 Device type(s). The device type(s) identify the circuit function as follows:

<u>Device type</u>	<u>Generic number</u>	<u>Circuit function</u>
01	54ACT05	Hex inverter with open drain outputs, TTL compatible inputs.

1.2.3 Device class designator. The device class designator is a single letter identifying the product assurance level as follows:

<u>Device class</u>	<u>Device requirements documentation</u>
M	Vendor self-certification to the requirements for MIL-STD-883 compliant, non-JAN class level B microcircuits in accordance with MIL-PRF-38535, appendix A
Q or V	Certification and qualification to MIL-PRF-38535

1.2.4 Case outline(s). The case outline(s) are as designated in MIL-STD-1835 and as follows:

<u>Outline letter</u>	<u>Descriptive designator</u>	<u>Terminals</u>	<u>Package style</u>
C	GDFP1-T14	14	Dual-in-line package

1.2.5 Lead finish. The lead finish is as specified in MIL-PRF-38535 for device classes Q and V or MIL-PRF-38535, appendix A for device class M.

<b>STANDARD MICROCIRCUIT DRAWING DEFENSE SUPPLY CENTER COLUMBUS COLUMBUS, OHIO 43216-5000</b>	<b>SIZE A</b>		<b>5962-90686</b>
		REVISION LEVEL	SHEET 2

1.3 Absolute maximum ratings. 1/ 2/ 3/

[查询"5962-90686-01CA"供应商](#)

Supply voltage range ( $V_{CC}$ ).....	-0.5 V dc to +6.0 V dc
DC input voltage range ( $V_{IN}$ ).....	-0.5 V dc to $V_{CC} +0.5$ V dc
DC output voltage range ( $V_{OUT}$ ).....	-0.5 V dc to $V_{CC} +0.5$ V dc
DC input diode current ( $I_{IK}$ ) ( $V_{IN} < -0.5$ V or $V_{IN} > V_{CC} +0.5$ V).....	$\pm 20$ mA
DC output diode current ( $I_{OK}$ ) ( $V_{OUT} < -0.5$ V or $V_{OUT} > V_{CC} +0.5$ V).....	$\pm 50$ mA
DC output source or sink current ( $I_{OUT}$ ) (per output pin).....	$\pm 50$ mA
DC $V_{CC}$ or GND current.....	$\pm 100$ mA
Storage temperature range ( $T_{STG}$ ).....	-65°C to +150°C
Lead temperature (soldering, 10 seconds).....	+300°C
Thermal resistance, junction-to-case ( $\theta_{JC}$ ).....	See MIL-STD-1835
Junction temperature ( $T_J$ ).....	+175°C
Maximum power dissipation ( $P_D$ ):.....	500 mW

1.4 Recommended operating conditions. 2/ 3/

Supply voltage range ( $V_{CC}$ ).....	+4.5 V dc to +5.5 V dc
Input voltage range ( $V_{IN}$ ).....	+0.0 V dc to $V_{CC}$
Output voltage range ( $V_{OUT}$ ).....	+0.0 V dc to $V_{CC}$
Minimum High level input voltage ( $V_{IH}$ ).....	+2.0 V
Maximum Low level input voltage ( $V_{IL}$ ).....	+0.8 V
Case operating temperature range ( $T_C$ ).....	-55°C to +125°C
Maximum input transition rise or fall rate ( $\Delta t/\Delta V$ ) (outputs enabled).....	10 ns/V

- 1/ Stresses above the absolute maximum rating may cause permanent damage to the device. Extended operation at the maximum levels may degrade performance and affect reliability.
- 2/ Unless otherwise noted, all voltages are referenced to GND.
- 3/ The limits for the parameters specified herein shall apply over the full specified  $V_{CC}$  range and case temperature range of -55°C to +125°C.

<b>STANDARD MICROCIRCUIT DRAWING DEFENSE SUPPLY CENTER COLUMBUS COLUMBUS, OHIO 43216-5000</b>	<b>SIZE A</b>		<b>5962-90686</b>
		REVISION LEVEL	SHEET 3

2. APPLICABLE DOCUMENTS

[查询"5962-90686"供应商](#)  
Government specification, standards, and handbooks. The following specification, standards, and handbooks form a part of this drawing to the extent specified herein. Unless otherwise specified, the issues of these documents are those listed in the issue of the Department of Defense Index of Specifications and Standards (DoDISS) and supplement thereto, cited in the solicitation.

SPECIFICATION

DEPARTMENT OF DEFENSE

MIL-PRF-38535 - Integrated Circuits, Manufacturing, General Specification for.

STANDARDS

DEPARTMENT OF DEFENSE

- MIL-STD-883 - Test Methods and Procedures for Microelectronics.
- MIL-STD-973 - Configuration Management.
- MIL-STD-1835 - Microcircuit Case Outlines.

HANDBOOKS

DEPARTMENT OF DEFENSE

- MIL-HDBK-103 - List of Standard Microcircuit Drawings (SMD's).
- MIL-HDBK-780 - Standard Microcircuit Drawings.

(Unless otherwise indicated, copies of the specification, standards, and handbooks are available from the Standardization Document Order Desk, 700 Robbins Avenue, Building 4D, Philadelphia, PA 19111-5094.)

2.2 Order of precedence. In the event of a conflict between the text of this drawing and the references cited herein, the text of this drawing takes precedence. Nothing in this document, however, supersedes applicable laws and regulations unless a specific exemption has been obtained.

3. REQUIREMENTS

3.1 Item requirements. The individual item requirements for device classes Q and V shall be in accordance with MIL-PRF-38535 and as specified herein or as modified in the device manufacturer's Quality Management (QM) plan. The modification in the QM plan shall not affect the form, fit, or function as described herein. The individual item requirements for device class M shall be in accordance with MIL-PRF-38535, appendix A for non-JAN class level B devices and as specified herein.

3.2 Design, construction, and physical dimensions. The design, construction, and physical dimensions shall be as specified in MIL-PRF-38535 and herein for device classes Q and V or MIL-PRF-38535, appendix A and herein for device class M.

3.2.1 Case outlines. The case outlines shall be in accordance with 1.2.4 herein.

3.2.2 Terminal connections. The terminal connections shall be as specified on figure 1.

3.2.3 Truth table. The truth table shall be as specified on figure 2.

3.2.4 Logic diagram. The logic diagram shall be as specified on figure 3.

3.2.5 Switching waveforms and test circuit. The switching waveforms and test circuit shall be as specified on figure 4.

<b>STANDARD MICROCIRCUIT DRAWING DEFENSE SUPPLY CENTER COLUMBUS COLUMBUS, OHIO 43216-5000</b>	<b>SIZE A</b>		<b>5962-90686</b>
		REVISION LEVEL	SHEET 4

3.2.6 Radiation exposure circuit. The radiation exposure circuit shall be as specified when available.

[查询"5962-90686"供应商](#)  
3.3 Electrical performance characteristics and postirradiation parameter limits. Unless otherwise specified herein, the electrical performance characteristics and postirradiation parameter limits are as specified in table I and shall apply over the full case operating temperature range.

3.4 Electrical test requirements. The electrical test requirements shall be the subgroups specified in table II. The electrical tests for each subgroup are defined in table I.

3.5 Marking. The part shall be marked with the PIN listed in 1.2 herein. In addition, the manufacturer's PIN may also be marked as listed in MIL-HDBK-103. For packages where marking of the entire SMD PIN number is not feasible due to space limitations, the manufacturer has the option of not marking the "5962-" on the device. For RHA product using this option, the RHA designator shall still be marked. Marking for device classes Q and V shall be in accordance with MIL-PRF-38535. Marking for device class M shall be in accordance with MIL-PRF-38535, appendix A.

3.5.1 Certification/compliance mark. The certification mark for device classes Q and V shall be a "QML" or "Q" as required in MIL-PRF-38535. The compliance mark for device class M shall be a "C" as required in MIL-PRF-38535, appendix A.

3.6 Certificate of compliance. For device classes Q and V, a certificate of compliance shall be required from a QML-38535 listed manufacturer in order to supply to the requirements of this drawing (see 6.6.1 herein). For device class M, a certificate of compliance shall be required from a manufacturer in order to be listed as an approved source of supply in MIL-HDBK-103 (see 6.6.2 herein). The certificate of compliance submitted to DSCC-VA prior to listing as an approved source of supply for this drawing shall affirm that the manufacturer's product meets, for device classes Q and V, the requirements of MIL-PRF-38535 and herein or for device class M, the requirements of MIL-PRF-38535, appendix A and herein.

3.7 Certificate of conformance. A certificate of conformance as required for device classes Q and V in MIL-PRF-38535 or for device class M in MIL-PRF-38535, appendix A shall be provided with each lot of microcircuits delivered to this drawing.

3.8 Notification of change for device class M. For device class M, notification to DSCC-VA of change of product (see 6.2 herein) involving devices acquired to this drawing is required for any change as defined in MIL-STD-973.

3.9 Verification and review for device class M. For device class M, DSCC, DSCC's agent, and the acquiring activity retain the option to review the manufacturer's facility and applicable required documentation. Offshore documentation shall be made available onshore at the option of the reviewer.

3.10 Microcircuit group assignment for device class M. Device class M devices covered by this drawing shall be in microcircuit group number 36 (see MIL-PRF-38535, appendix A).

<b>STANDARD MICROCIRCUIT DRAWING DEFENSE SUPPLY CENTER COLUMBUS COLUMBUS, OHIO 43216-5000</b>	<b>SIZE A</b>		<b>5962-90686</b>
		REVISION LEVEL	SHEET 5

DSCC FORM 2234  
APR 97

TABLE I. Electrical performance characteristics.

Test and MIL-STD-883 test method <u>1/</u>	Symbol	Test conditions <u>2/</u> -55°C ≤ T <sub>C</sub> ≤ +125°C +4.5 V ≤ V <sub>CC</sub> ≤ +5.5 V unless otherwise specified	V <sub>CC</sub>	Group A subgroups	Limits <u>3/</u>		Unit
					Min	Max	
High level input voltage	V <sub>IH</sub>		4.5 V	1, 2, 3	2.0		V
			5.5 V	1, 2, 3	2.0		
Low level input voltage	V <sub>IL</sub>		4.5 V	1, 2, 3		0.8	V
			5.5 V	1, 2, 3		0.8	
Low level output voltage 3007	V <sub>OL</sub>	V <sub>IN</sub> = V <sub>IH</sub> or V <sub>IL</sub> I <sub>OL</sub> = 50 μA	4.5 V and 5.5 V	1, 2, 3		0.10	V
			4.5 V and 5.5 V	1		0.36	
				2, 3		0.50	
Quiescent supply current 3005	I <sub>CC</sub>	V <sub>IN</sub> = V <sub>CC</sub> or GND I <sub>OUT</sub> = 0.0 A	4.5 V and 5.5 V	1		4.0	μA
				2, 3		80.0	
Quiescent supply current delta, TTL input levels 3005	ΔI <sub>CC</sub>	V <sub>IN</sub> = V <sub>CC</sub> - 2.1 V	4.5 V and 5.5 V	1		2.4	mA
				2, 3		3.0	
Input capacitance 3012	C <sub>IN</sub>	T <sub>C</sub> = +25°C See 4.4.1c	5.0 V	4		10.0	pF
Power dissipation capacitance 3012	C <sub>PD</sub> <u>5/</u>	T <sub>C</sub> = +25°C See 4.4.1c	5.0 V	4		105	pF
Functional test 3014	<u>6/</u>	V <sub>IH</sub> = 2.0 V, V <sub>IL</sub> = 0.8 V Verify output V <sub>OUT</sub> See 4.4.1b	4.5 V	7, 8	L	H	
			5.5 V	7, 8	L	H	
Propagation delay time, output low to high impedance 3003	t <sub>PLZ</sub> <u>7/</u>	C <sub>L</sub> = 50 pF minimum R <sub>L</sub> = 500Ω See figure 5	5.0 V	9, 10, 11	2.7	10.8	ns
Propagation delay time, high impedance to output low 3003	t <sub>PZL</sub> <u>7/</u>		5.0 V	9, 10, 11	2.3	9.3	

See footnotes at end of table.

<b>STANDARD MICROCIRCUIT DRAWING DEFENSE SUPPLY CENTER COLUMBUS COLUMBUS, OHIO 43216-5000</b>	<b>SIZE A</b>		<b>5962-90686</b>
		REVISION LEVEL	SHEET 6

DSCC FORM 2234  
APR 97

TABLE I. Electrical performance characteristics – Continued.  
[查询"5962-9068601QCA"供应商](#)

- 1/ For tests not listed in the referenced MIL-STD-883 (e.g.  $\Delta I_{CC}$ ), utilize the general test procedure of 883 under the conditions listed herein.
- 2/ Each input/output, as applicable, shall be tested at the specified temperature, for the specified limits, to the tests in table I herein. Output terminals not designated shall be high level logic, low level logic, or open, except for all  $I_{CC}$  and  $\Delta I_{CC}$  tests, where the output terminals shall be open. When performing these tests, the current meter shall be placed in the circuit such that all current flows through the meter. For input terminals not designated,  $V_{IN} = GND$  or  $V_{IN} \geq 4.5 V$ .
- 3/ For negative and positive voltage and current values, the sign designates the potential difference in reference to GND and the direction of current flow, respectively; and the absolute value of the magnitude, not the sign, is relative to the minimum and maximum limits, as applicable, listed herein. All devices shall meet or exceed the limits specified in table I at  $4.5 V \leq V_{CC} \leq 5.5 V$ .
- 4/ Test one output at a time for a 1 second maximum duration. Measurement is made by forcing current and measuring voltage to minimize power dissipation. Test verifies a minimum of  $75\Omega$  transmission line-drive capability at  $+125^\circ C$ .
- 5/ Power dissipation capacitance ( $C_{PD}$ ) determines the no load power consumption,  $P_D = (C_{PD} + C_L) (V_{CC} \times V_{CC}) f + (I_{CC} \times V_{CC}) + (n \times d \times \Delta I_{CC} \times V_{CC})$ . The dynamic current consumption  $I_S = (C_{PD} + C_L) V_{CC} f + I_{CC} + (n \times d \times \Delta I_{CC})$ . For both  $P_D$  and  $I_S$ : n is the number of device inputs at TTL levels; f is the frequency of the input signal; d is the duty cycle of the input signal; and  $C_L$  is the external output load capacitor.
- 6/ Tests shall be performed in sequence, attributes data only. Functional tests shall include the truth table and other logic patterns used for fault detection. The test vectors used to verify the truth table shall, at a minimum, test all functions of each input and output. All possible input to output logic patterns per function shall be guaranteed, if not tested, to the truth table in figure 2 herein. Functional tests shall be performed in sequence as approved by the qualifying activity on qualified devices. After incorporating allowable tolerances per MIL-STD-883,  $V_{IL} = 0.4 V$  and  $V_{IH} = 2.4 V$ . For outputs,  $L \leq 0.8 V$ ,  $H \geq 2.0 V$ .
- 7/ For propagation delay tests, all paths must be tested.

<b>STANDARD          MICROCIRCUIT DRAWING          DEFENSE SUPPLY CENTER COLUMBUS          COLUMBUS, OHIO 43216-5000</b>	<b>SIZE          A</b>		<b>5962-90686</b>
		REVISION LEVEL	SHEET 7

[查询"5962-9068601QCA"供应商](#)

Device type	01
Case Outline	C
Terminal Number	Terminal Symbol
1	<u>1A</u>
2	<u>1Y</u>
3	<u>2A</u>
4	<u>2Y</u>
5	<u>3A</u>
6	<u>3Y</u>
7	<u>GND</u>
8	<u>4Y</u>
9	<u>4A</u>
10	<u>5Y</u>
11	<u>5A</u>
12	<u>6Y</u>
13	<u>6A</u>
14	V <sub>CC</sub>

FIGURE 1. Terminal connections.

Inputs mA	Outputs mY
L	Z
H	L

m = 1 to 6  
H = High voltage level.  
L = Low voltage level.  
Z = High impedance.

FIGURE 2. Truth table.

<b>STANDARD  MICROCIRCUIT DRAWING  DEFENSE SUPPLY CENTER COLUMBUS  COLUMBUS, OHIO 43216-5000</b>	<b>SIZE  A</b>		<b>5962-90686</b>
		REVISION LEVEL	SHEET 8

DSCC FORM 2234  
APR 97

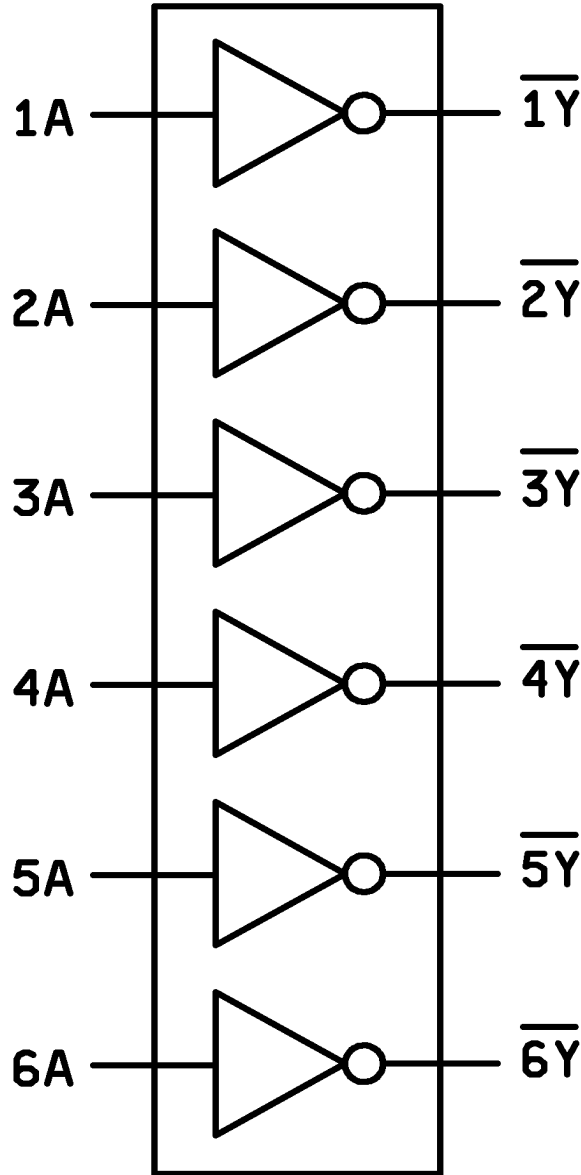
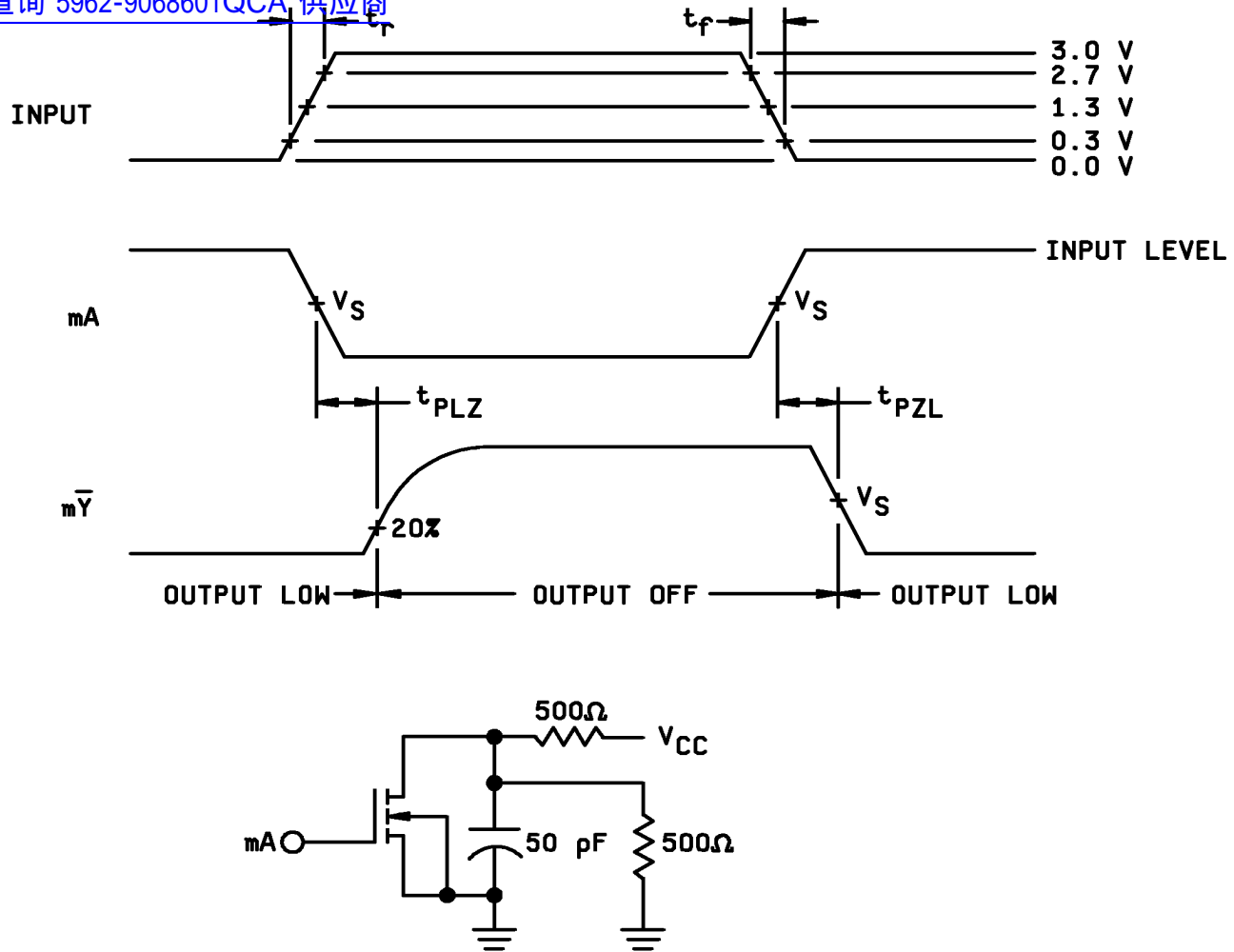

FIGURE 3. Logic diagram.

<b>STANDARD MICROCIRCUIT DRAWING DEFENSE SUPPLY CENTER COLUMBUS COLUMBUS, OHIO 43216-5000</b>	<b>SIZE A</b>		<b>5962-90686</b>
		REVISION LEVEL	SHEET 9



NOTES:

1.  $C_L = 50 \text{ pF}$  minimum or equivalent (includes jig and probe capacitance).
2.  $R_L = 500\Omega$  or equivalent.
3. Input signal from pulse generator:  $V_{IN} = 0.0 \text{ V}$  to  $3.0 \text{ V}$ ;  $PRR \leq 10 \text{ MHz}$   $t_r \leq 3.0 \text{ ns}$ ;  $t_r$  and  $t_f$  shall be measured from  $0.3 \text{ V}$  to  $2.7 \text{ V}$  and from  $2.7 \text{ V}$  to  $0.3 \text{ V}$  respectively.

FIGURE 4. Switching waveforms and test circuit.

<p align="center"><b>STANDARD MICROCIRCUIT DRAWING DEFENSE SUPPLY CENTER COLUMBUS COLUMBUS, OHIO 43216-5000</b></p>	<p align="center"><b>SIZE A</b></p>		<p align="center"><b>5962-90686</b></p>
		<p align="center">REVISION LEVEL</p>	<p align="center">SHEET 10</p>

4. QUALITY ASSURANCE PROVISIONS

[查询"5962-90686"QCA"供应商](#)  
 4.1 Sampling and inspection. For device classes Q and V, sampling and inspection procedures shall be in accordance with MIL-PRF-38535 or as modified in the device manufacturer's Quality Management (QM) plan. The modification in the QM plan shall not affect the form, fit, or function as described herein. For device class M, sampling and inspection procedures shall be in accordance with MIL-PRF-38535, appendix A.

4.2 Screening. For device classes Q and V, screening shall be in accordance with MIL-PRF-38535, and shall be conducted on all devices prior to qualification and technology conformance inspection. For device class M, screening shall be in accordance with method 5004 of MIL-STD-883, and shall be conducted on all devices prior to quality conformance inspection.

4.2.1 Additional criteria for device class M.

- a. Burn-in test, method 1015 of MIL-STD-883.
  - (1) Test condition A, B, C, or D. The test circuit shall be maintained by the manufacturer under document revision level control and shall be made available to the preparing or acquiring activity upon request. The test circuit shall specify the inputs, outputs, biases, and power dissipation, as applicable, in accordance with the intent specified in test method 1015.
  - (2)  $T_A = +125^{\circ}\text{C}$ , minimum.
- b. Interim and final electrical test parameters shall be as specified in table II herein.

4.2.2 Additional criteria for device classes Q and V.

- a. The burn-in test duration, test condition and test temperature, or approved alternatives shall be as specified in the device manufacturer's QM plan in accordance with MIL-PRF-38535. The burn-in test circuit shall be maintained under document revision level control of the device manufacturer's Technology Review Board (TRB) in accordance with MIL-PRF-38535 and shall be made available to the acquiring or preparing activity upon request. The test circuit shall specify the inputs, outputs, biases, and power dissipation, as applicable, in accordance with the intent specified in test method 1015 of MIL-STD-883.
- b. Interim and final electrical test parameters shall be as specified in table II herein.
- c. Additional screening for device class V beyond the requirements of device class Q shall be as specified in MIL-PRF-38535, appendix B.

4.3 Qualification inspection for device classes Q and V. Qualification inspection for device classes Q and V shall be in accordance with MIL-PRF-38535. Inspections to be performed shall be those specified in MIL-PRF-38535 and herein for groups A, B, C, D, and E inspections (see 4.4.1 through 4.4.4).

4.3.1 Electrostatic discharge sensitivity qualification inspection. Electrostatic discharge sensitivity (ESDS) testing shall be performed in accordance with MIL-STD-883, method 3015. ESDS testing shall be measured only for initial qualification and after process or design changes which may affect ESDS classification.

4.4 Conformance inspection. Technology conformance inspection for classes Q and V shall be in accordance with MIL-PRF-38535 including groups A, B, C, D, and E inspections and as specified herein except where option 2 of MIL-PRF-38535 permits alternate in-line control testing. Quality conformance inspection for device class M shall be in accordance with MIL-PRF-38535, appendix A and as specified herein. Inspections to be performed for device class M shall be those specified in method 5005 of MIL-STD-883 and herein for groups A, B, C, D, and E inspections (see 4.4.1 through 4.4.4).

<b>STANDARD                  MICROCIRCUIT DRAWING                  DEFENSE SUPPLY CENTER COLUMBUS                  COLUMBUS, OHIO 43216-5000</b>	<b>SIZE                  A</b>		<b>5962-90686</b>
		REVISION LEVEL	SHEET 11

TABLE II. Electrical test requirements.

查询"5962-9068601QCA"供应商

Test requirements	Subgroups (in accordance with MIL-STD-883, method 5005, table I)	Subgroups (in accordance with MIL-PRF-38535, table III)	
	Device class M	Device class Q	Device class V
Interim electrical parameters (see 4.2)	---	---	1
Final electrical parameters (see 4.2)	1/ 1, 2, 3, 7, 8, 9, 10, 11	1/ 1, 2, 3, 7, 8, 9, 10, 11	2/ 1, 2, 3, 7, 8, 9, 10, 11
Group A test requirements (see 4.4)	1, 2, 3, 4, 7, 8, 9, 10, 11	1, 2, 3, 4, 7, 8, 9, 10, 11	1, 2, 3, 4, 7, 8, 9, 10, 11
Group C end-point electrical parameters (see 4.4)	1, 2, 3	1, 2, 3	1, 2, 3, 7, 8, 9, 10, 11
Group D end-point electrical parameters (see 4.4)	1, 2, 3	1, 2, 3	1, 2, 3
Group E end-point electrical parameters (see 4.4)	1, 7, 9	1, 7, 9	1, 7, 9

1/ PDA applies to subgroup 1.  
2/ PDA applies to subgroups 1 and 7.

4.4.1 Group A inspection.

- a. Tests shall be as specified in table II herein.
- b. For device class M, subgroups 7 and 8 tests shall be sufficient to verify the truth table in figure 2 herein. The test vectors used to verify the truth table shall, at a minimum, test all functions of each input and output. All possible input to output logic patterns per function shall be guaranteed, if not tested, to the truth table in figure 2, herein. For device classes Q and V, subgroups 7 and 8 shall include verifying the functionality of the device.
- c.  $C_{IN}$ , and  $C_{PD}$  shall be measured only for initial qualification and after process or design changes which may affect capacitance.  $C_{IN}$  and  $C_{PD}$  shall be measured between the designated terminal and GND at a frequency of 1 MHz. This test may be performed at 10 MHz and guaranteed, if not tested, at 1 MHz. The DC bias for the pin under test ( $V_{BIAS}$ ) = 2.5 V or 3.0 V. For  $C_{IN}$  and  $C_{PD}$  test all applicable pins on five devices with zero failures.

For  $C_{IN}$  and  $C_{PD}$  a device manufacturer may qualify devices by functional groups. A specific functional group shall be composed of function types, that by design, will yield the same capacitance values when tested in accordance with table I, herein. The device manufacturer shall set a function group limit for the  $C_{IN}$  and  $C_{PD}$  tests. The device manufacturer may then test one device functional group, to the limits and conditions specified herein. All other device functions in that particular functional group shall be guaranteed, if not tested, to the limits and test conditions specified in table I, herein. The device manufacturers shall submit to DSCC-VA the device functions listed in each functional group and the test results for each device tested.

<b>STANDARD MICROCIRCUIT DRAWING DEFENSE SUPPLY CENTER COLUMBUS COLUMBUS, OHIO 43216-5000</b>	<b>SIZE A</b>		<b>5962-90686</b>
		REVISION LEVEL	SHEET 12

4.4.2 Group C inspection. The group C inspection end-point electrical parameters shall be as specified in table II herein.

[查询"5962-9068601QCA"供应商](#)

4.4.2.1 Additional criteria for device class M. Steady-state life test conditions, method 1005 of MIL-STD-883:

- a. Test condition A, B, C, or D. The test circuit shall be maintained by the manufacturer under document revision level control and shall be made available to the preparing or acquiring activity upon request. The test circuit shall specify the inputs, outputs, biases, and power dissipation, as applicable, in accordance with the intent specified in test method 1005 of MIL-STD-883.
- b.  $T_A = +125^{\circ}\text{C}$ , minimum.
- c. Test duration: 1,000 hours, except as permitted by method 1005 of MIL-STD-883.

4.4.2.2 Additional criteria for device classes Q and V. The steady-state life test duration, test condition and test temperature, or approved alternatives shall be as specified in the device manufacturer's QM plan in accordance with MIL-PRF-38535. The test circuit shall be maintained under document revision level control by the device manufacturer's TRB in accordance with MIL-PRF-38535 and shall be made available to the acquiring or preparing activity upon request. The test circuit shall specify the inputs, outputs, biases, and power dissipation, as applicable, in accordance with the intent specified in test method 1005 of MIL-STD-883.

4.4.3 Group D inspection. The group D inspection end-point electrical parameters shall be as specified in table II herein.

4.4.4 Group E inspection. Group E inspection is required only for parts intended to be marked as radiation hardness assured (see 3.5 herein).

- a. End-point electrical parameters shall be as specified in table II herein.
- b. For device classes Q and V, the devices or test vehicle shall be subjected to radiation hardness assured tests as specified in MIL-PRF-38535 for the RHA level being tested. For device class M, the devices shall be subjected to radiation hardness assured tests as specified in MIL-PRF-38535, appendix A for the RHA level being tested. All device classes must meet the postirradiation end-point electrical parameter limits as defined in table I at  $T_A = +25^{\circ}\text{C} \pm 5^{\circ}\text{C}$ , after exposure, to the subgroups specified in table II herein.
- c. When specified in the purchase order or contract, a copy of the RHA delta limits shall be supplied.

4.5 Methods of inspection. Methods of inspection shall be specified as follows:

4.5.1 Voltage and current. Unless otherwise specified, all voltages given are referenced to the microcircuit GND terminal. Currents given are conventional current and positive when flowing into the referenced terminal.

## 5. PACKAGING

5.1 Packaging requirements. The requirements for packaging shall be in accordance with MIL-PRF-38535 for device classes Q and V or MIL-PRF-38535, appendix A for device class M.

## 6. NOTES

6.1 Intended use. Microcircuits conforming to this drawing are intended for use for Government microcircuit applications (original equipment), design applications, and logistics purposes.

6.1.1 Replaceability. Microcircuits covered by this drawing will replace the same generic device covered by a contractor-prepared specification or drawing.

<b>STANDARD MICROCIRCUIT DRAWING DEFENSE SUPPLY CENTER COLUMBUS COLUMBUS, OHIO 43216-5000</b>	<b>SIZE A</b>		<b>5962-90686</b>
		REVISION LEVEL	SHEET 13

6.1.2 Substitutability. Device class Q devices will replace device class M devices.

[查询"5962-9068601QCA"供应商](#)

~~6.2 Configuration control of SMD's. All proposed changes to existing SMD's will be coordinated with the users of record for the individual documents. This coordination will be accomplished in accordance with MIL-STD-973 using DD Form 1692, Engineering Change Proposal.~~

6.3 Record of users. Military and industrial users should inform Defense Supply Center Columbus when a system application requires configuration control and which SMD's are applicable to that system. DSCC will maintain a record of users and this list will be used for coordination and distribution of changes to the drawings. Users of drawings covering microelectronic devices (FSC 5962) should contact DSCC-VA, telephone (614) 692-0674.

6.4 Comments. Comments on this drawing should be directed to DSCC-VA , Columbus, Ohio 43216-5000, or telephone (614) 692-0674.

6.5 Abbreviations, symbols, and definitions. The abbreviations, symbols, and definitions used herein are defined in MIL-PRF-38535 and MIL-HDBK-1331.

6.6 Sources of supply.

6.6.1 Sources of supply for device classes Q and V. Sources of supply for device classes Q and V are listed in QML-38535. The vendors listed in QML-38535 have submitted a certificate of compliance (see 3.6 herein) to DSCC-VA and have agreed to this drawing.

6.6.2 Approved sources of supply for device class M. Approved sources of supply for class M are listed in MIL-HDBK-103. The vendors listed in MIL-HDBK-103 have agreed to this drawing and a certificate of compliance (see 3.6 herein) has been submitted to and accepted by DSCC-VA.

<b>STANDARD MICROCIRCUIT DRAWING DEFENSE SUPPLY CENTER COLUMBUS COLUMBUS, OHIO 43216-5000</b>	<b>SIZE A</b>		<b>5962-90686</b>
		REVISION LEVEL	SHEET 14

DSCC FORM 2234  
APR 97

查询"5962-9068601QCA"供应商  
 STANDARD MICROCIRCUIT DRAWING SOURCE APPROVAL BULLETIN  
 DATE: 99-06-03

Approved sources of supply for SMD 5962-90686 are listed below for immediate acquisition information only and shall be added to MIL-HDBK-103 and QML-38535 during the next revision. MIL-HDBK-103 and QML-38535 will be revised to include the addition or deletion of sources. The vendors listed below have agreed to this drawing and a certificate of compliance has been submitted to and accepted by DSCC-VA. This bulletin is superseded by the next dated revision of MIL-HDBK-103 and QML-38535.

Standard microcircuit drawing PIN <u>1/</u>	Vendor CAGE number	Vendor similar PIN <u>2/</u>
5962-9068601QCA	01295	CD54ACT05F3A

1/ The lead finish shown for each PIN representing a hermetic package is the most readily available from the manufacturer listed for that part. If the desired lead finish is not listed contact the Vendor to determine its availability.

2/ Caution. Do not use this number for item acquisition. Items acquired to this number may not satisfy the performance requirements of this drawing.

Vendor CAGE number

01295

Vendor name and address

Texas Instruments Incorporated  
 13500 N. Central Expressway  
 P.O. Box 655303  
 Dallas, TX 75265  
 Point of contact: 6412 Highway 75 South  
 Sherman, TX 75090-0084

The information contained herein is disseminated for convenience only and the Government assumes no liability whatsoever for any inaccuracies in the information bulletin.