

## A5F:240.XXHY

### VOLTAGE RATINGS

| Part Number  | V <sub>RRM</sub> , V <sub>R</sub> – (V) Max. rep. peak reverse voltage |                              | V <sub>RSM</sub> , V <sub>R</sub> – (V) Max. non-rep. peak reverse voltage |
|--------------|--|------------------------------|--|
|              | T <sub>J</sub> = 0 to 125 °C   | T <sub>J</sub> = -40 to 0 °C |  |
| A5F:240.02HY | 200  | 200                          | 300  |
| A5F:240.04HY | 400  | 400                          | 500  |
| A5F:240.06HY | 600  | 600                          | 700  |
| A5F:240.08HY | 800  | 800                          | 900  |
| A5F:240.10HY | 1000   | 1000                         | 1100   |
| A5F:240.12HY | 1200   | 1200                         | 1300   |
| A5F:240.14HY | 1400   | 1400                         | 1500   |
| A5F:240.16HY | 1600   | 1600                         | 1700   |

### MAXIMUM ALLOWABLE RATINGS

| PARAMETER   | VALUE      | UNITS                            | NOTES   |
|---|------------|----------------------------------|---|
| T <sub>J</sub> Junction Temperature   | -40 to 125 | °C                               | -   |
| T <sub>stg</sub> Storage Temperature  | -40 to 150 | °C                               | -   |
| I <sub>F(AV)</sub> Max. Av. current @ Max. T <sub>C</sub>                       | 240        | A                                | 180° half sine wave   |
|   | 70         | °C                               |   |
| I <sub>F(RMS)</sub> Nom. RMS current  | 380        | A                                | -   |
| I <sub>FSM</sub> Max. Peak non-rep. surge current                               | 3.8        | kA                               | 50 Hz half cycle sine wave Initial T <sub>J</sub> = 125°C, rated V <sub>RRM</sub> applied after surge.  |
|   | 4.1        |                                  | 60 Hz half cycle sine wave  |
|   | 4.3        |                                  | 50 Hz half cycle sine wave Initial T <sub>J</sub> = 125°C, no voltage applied after surge.  |
|   | 4.7        |                                  | 60 Hz half cycle sine wave  |
| I <sup>2</sup> t Max. I <sup>2</sup> t capability                               | 54         | kA <sup>2</sup> s                | t = 10ms Initial T <sub>J</sub> = 125°C, rated V <sub>RRM</sub> applied after surge.  |
|   | 59         |                                  | t = 8.3 ms  |
|   | 61         |                                  | t = 10ms Initial T <sub>J</sub> = 125°C, no voltage applied after surge.  |
|   | 67         |                                  | t = 8.3 ms  |
| I <sup>2</sup> t <sup>1/2</sup> Max. I <sup>2</sup> t <sup>1/2</sup> capability | 1050       | kA <sup>2</sup> s <sup>1/2</sup> | Initial T <sub>J</sub> = 125°C, no voltage applied after surge. <sup>†</sup> t for time t <sub>x</sub> = I <sup>2</sup> t <sup>1/2</sup> * t <sub>x</sub> <sup>1/2</sup> . (0.1 < t <sub>x</sub> < 10ms). |
| di/dt Max. Non-repetitive rate-of-rise current                                  | 800        | A/μs                             | T <sub>J</sub> = 125°C, V <sub>D</sub> = V <sub>DRM</sub> , I <sub>TM</sub> = 754A. Gate pulse: 20V, 20Ω, 10μs, 0.5μs rise time, Max. repetitive di/dt is approximately 40% of non-repetitive value.      |
| P <sub>G(M)</sub> Max. Peak gate power  | 10         | W                                | t <sub>p</sub> < 5 ms   |
| P <sub>G(AV)</sub> Max. Av. gate power  | 2          | W                                | -   |
| F Mounting Force  | 450        | N.m                              | -   |

## A5F:240.XXHY

### CHARACTERISTICS

| PARAMETER  | MIN.        | TYP.       | MAX.                    | UNITS                     | TEST CONDITIONS  |
|--|-------------|------------|-------------------------|---------------------------|--|
| $V_{TM}$ peak on-state voltage                         | ---         | 2.38       | 2.53                    | V                         | Initial $T_J = 25^\circ\text{C}$ , 50-60Hz half sine, $I_{\text{peak}} = 754\text{A}$ .  |
| $V_{T(TO)}$ Threshold voltage                          | ---         | ---        | 1.39                    | V                         | $T_J = 125^\circ\text{C}$<br>Av. power = $V_{T(TO)} * I_{T(AV)} + r_T * [I_{T(RMS)}]^2$  |
| $r_T$ Slope resistance                                 | ---         | ---        | 1.53                    | m $\Omega$                | Use low values for $I_M < \pi$ rated $I_{T(AV)}$   |
| $I_L$ Latching current                                 | ---         | 270        | ---                     | mA                        | $T_C = 25^\circ\text{C}$ , 12V anode. Gate pulse: 10V, 20 $\Omega$ , 100 $\mu\text{s}$ .   |
| $I_H$ Holding current                                  | ---         | 100        | 500                     | mA                        | $T_C = 25^\circ\text{C}$ , 12V anode. Initial $I_T = 10\text{A}$ .   |
| $t_d$ Delay time                                       | ---         | 1.1        | ---                     | $\mu\text{s}$             | $T_C = 25^\circ\text{C}$ , $V_D = \text{rated } V_{\text{DRM}}$ , 50A resistive load. Gate pulse: 10V, 20 $\Omega$ , 10 $\mu\text{s}$ , 1 $\mu\text{s}$ rise time.   |
| $t_q$ Turn-off time                                    | ---         | ---        | 15-60                   | $\mu\text{s}$             | $T_J = 125^\circ\text{C}$ , $I_{TM} = 500\text{A}$ , $di/dt = 25\text{A}/\mu\text{s}$ , $V_R = 50\text{V}$ . $dv/dt = 200\text{V}/\mu\text{s}$ lin. To 80% rated $V_{\text{DRM}}$ . Gate: 0V, 100 $\Omega$ . |
| $I_{RM(REC)}$ Recovery current                         | ---         | 75         | ---                     | A                         | $T_J = 125^\circ\text{C}$ , $I_{TM} = 754\text{A}$ , $diR/dt = 50\text{A}/\mu\text{s}$ .   |
| $dv/dt$ Critical rate-of-rise of off-state voltage     | 500<br>1000 | 700<br>--- | ---                     | V/ $\mu\text{s}$          | $T_J = 125^\circ\text{C}$ . Exp. to 100% or lin. Higher $dv/dt$ values available.<br>To 80% $V_{\text{DRM}}$ , gate open.<br>$T_J = 125^\circ\text{C}$ , Exp. To 67% $V_{\text{DRM}}$ , gate open.           |
| $I_{RM}$ , $I_{DM}$ Peak reverse and off-state current | ---         | 30         | ---                     | mA                        | $T_J = 125^\circ\text{C}$ , Rated $V_{\text{RRM}}$ and $V_{\text{DRM}}$ , gate open.   |
| $I_{GT}$ DC gate current to trigger                    | 300<br>150  | ---        | ---                     | mA                        | $T_C = -40^\circ\text{C}$<br>$T_C = 25^\circ\text{C}$ +12V anode-to-cathode. For recommended gate drive see "Gate Characteristics" figure.   |
| $V_{GT}$ DC gate voltage to trigger                    | ---         | ---        | 3.3<br>2.5              | V                         | $T_C = -40^\circ\text{C}$<br>$T_C = 25^\circ\text{C}$  |
| $V_{GD}$ DC gate voltage not to trigger                | ---         | ---        | 0.3                     | V                         | $T_C = 25^\circ\text{C}$ , Max. Value which will not trigger with rated $V_{\text{DRM}}$ anode-to-cathode.   |
| $R_{\text{thJC}}$ Thermal resistance, junction-to-case | ---         | ---        | 0.085<br>0.104<br>0.109 | $^\circ\text{C}/\text{W}$ | DC operation.<br>180 $^\circ$ sine wave, double side cooled.<br>120 $^\circ$ rectangular wave, double side cooled.   |
| $R_{\text{thCS}}$ Thermal resistance, case-to-sink     | ---         | ---        | 0.03                    | $^\circ\text{C}/\text{W}$ | Mtg. Surface smooth, flat and greased.   |
| wt Weight  | ---         | 50(1.8)    | ---                     | g(oz.)                    | ---  |
| Case Style   | TO-200AA    |            | JEDEC                   | ---                       | ---  |

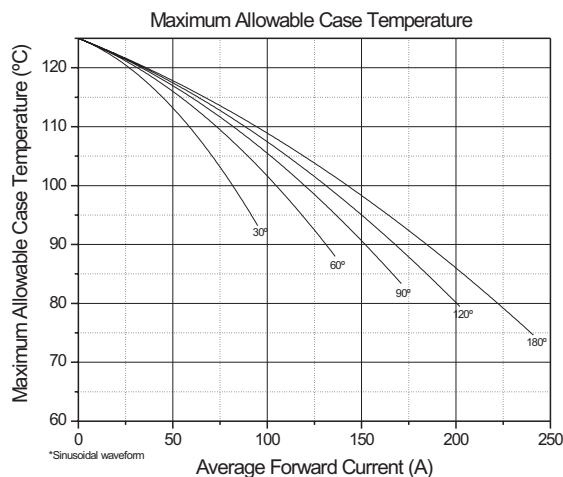

Fig. 1 - Current Ratings Characteristics

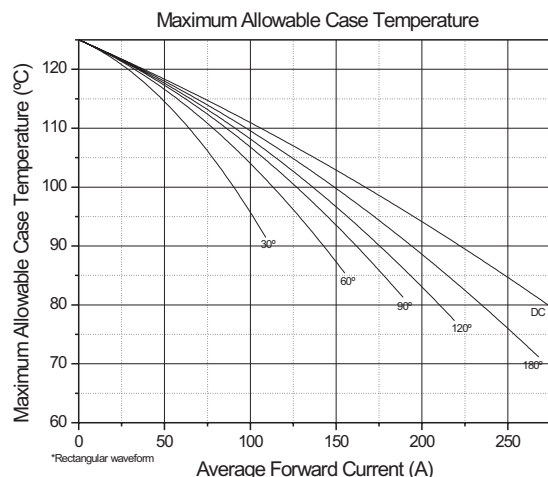

Fig. 2 - Current Ratings Characteristics

# A5F:240.XXHY

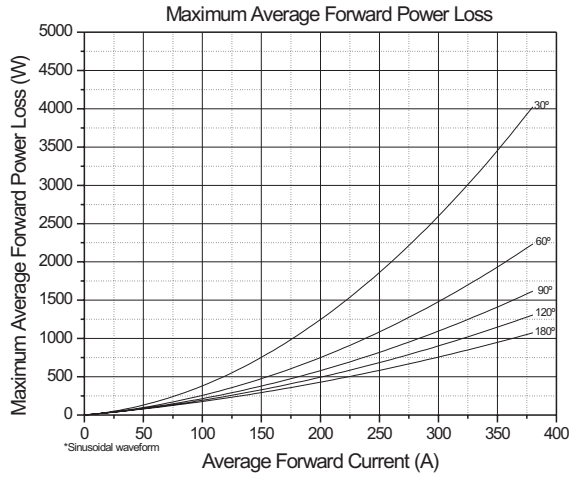

Fig. 3 - On-State Power Loss Characteristics

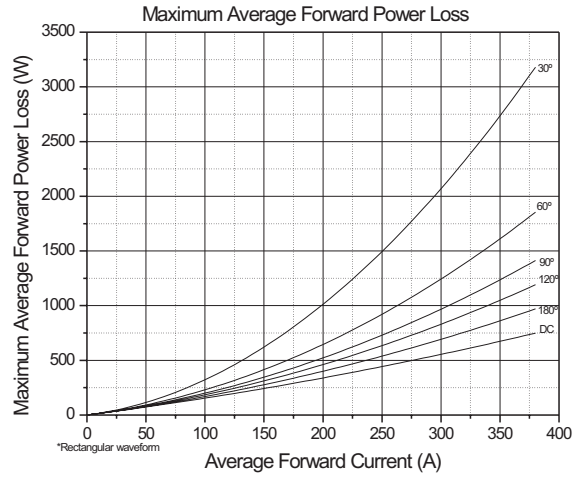

Fig. 4 - On-State Power Loss Characteristics

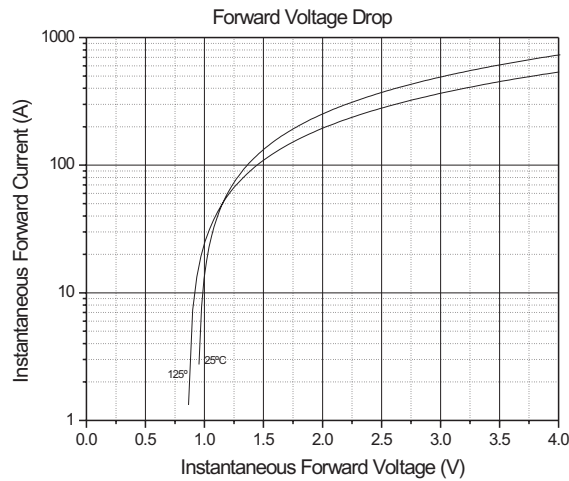

Fig. 5 - Forward Voltage Drop Characteristics

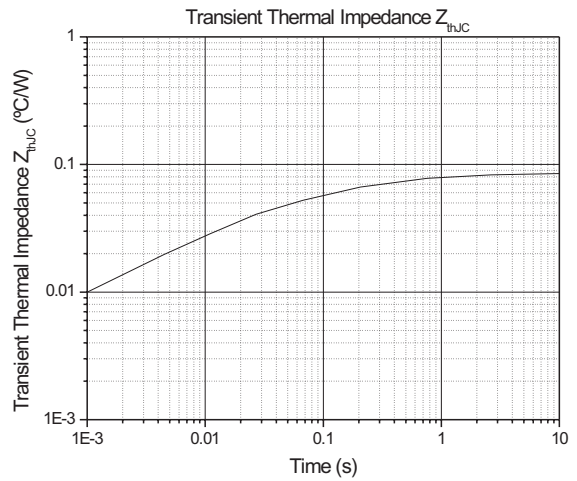

Fig. 6 - Transient Thermal Impedance Characteristics

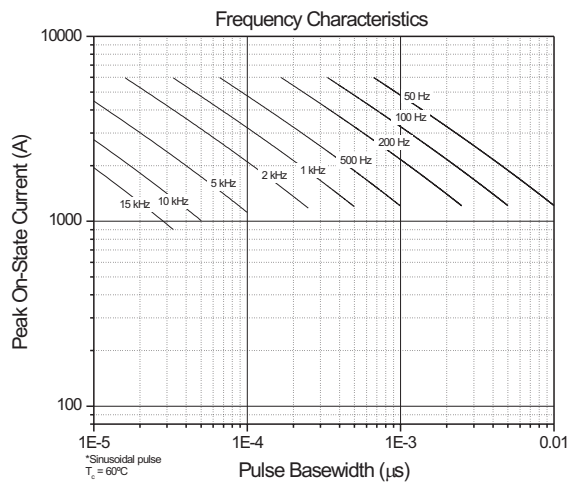

Fig. 7 - Frequency Characteristics

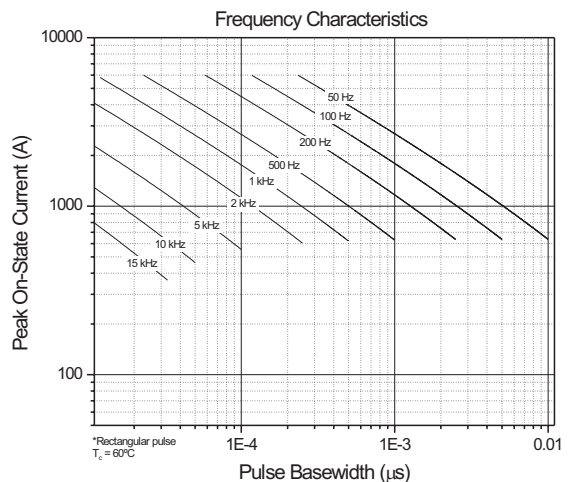

Fig. 8 - Frequency Characteristics

# A5F:240.XXHY

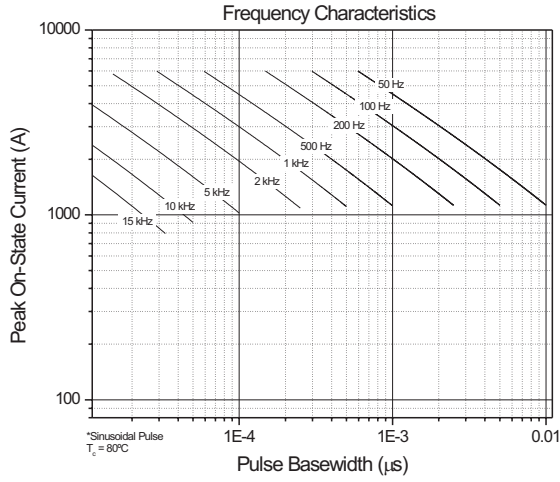

Fig. 9 - Frequency Characteristics

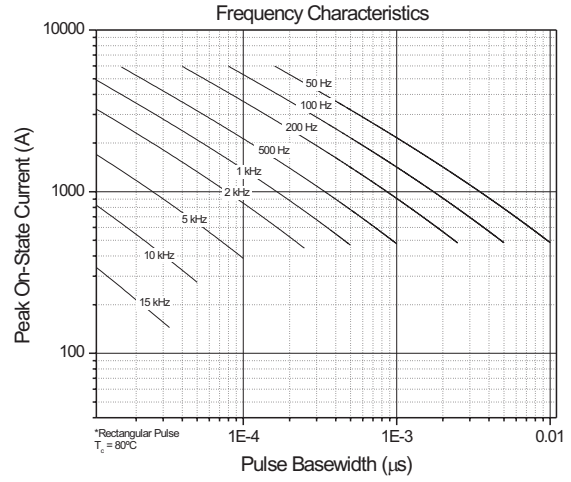

Fig. 10 - Frequency Characteristics

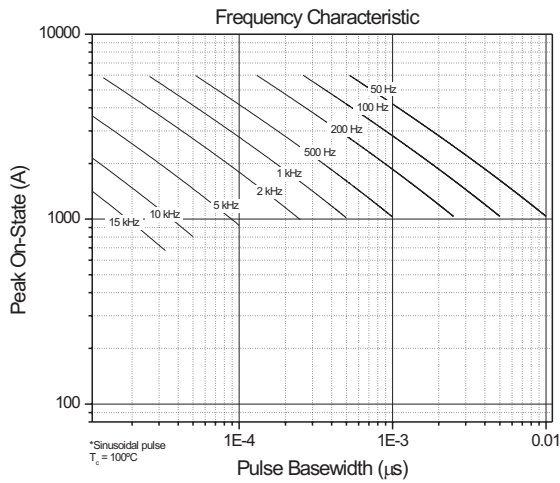

Fig. 11 - Frequency Characteristics

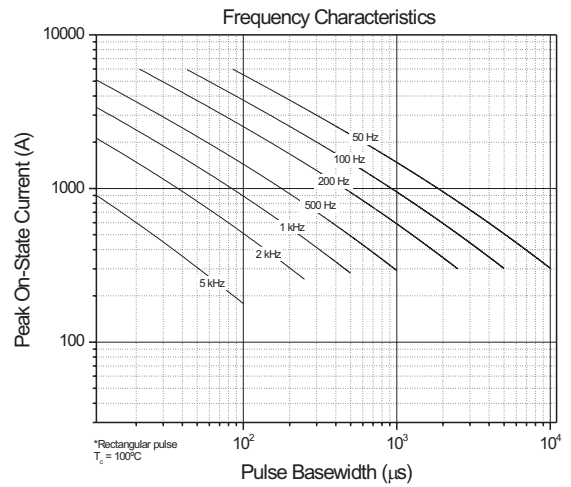

Fig. 12 - Frequency Characteristics

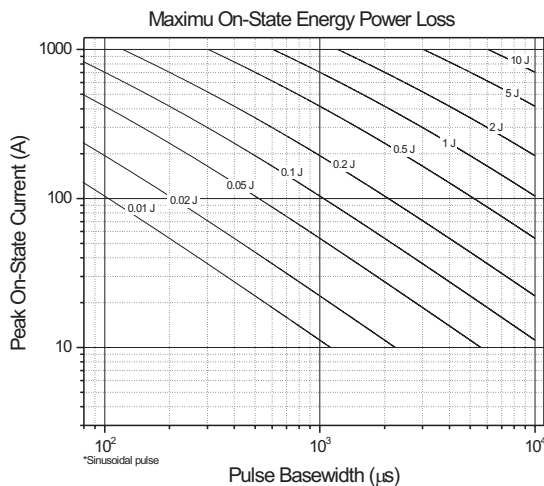

Fig. 13 - Frequency Characteristics

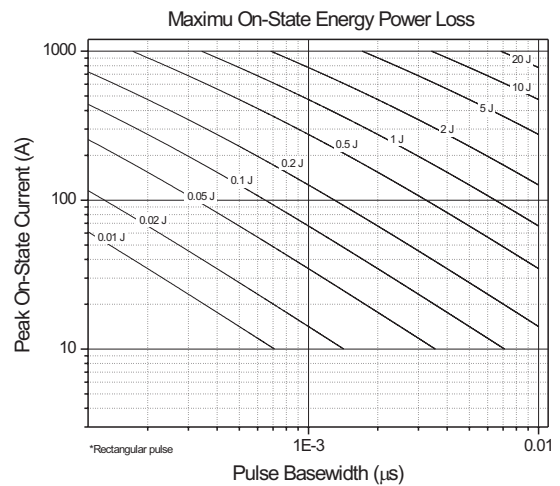

Fig. 14 - Frequency Characteristics

## A5F:240.XXHY

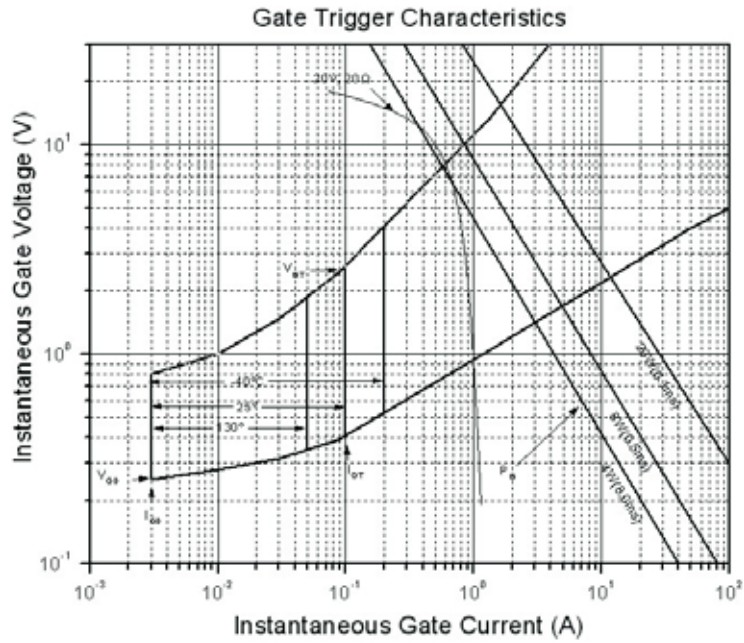

Fig. 15 - Gate Trigger Characteristics

## TO-200AA

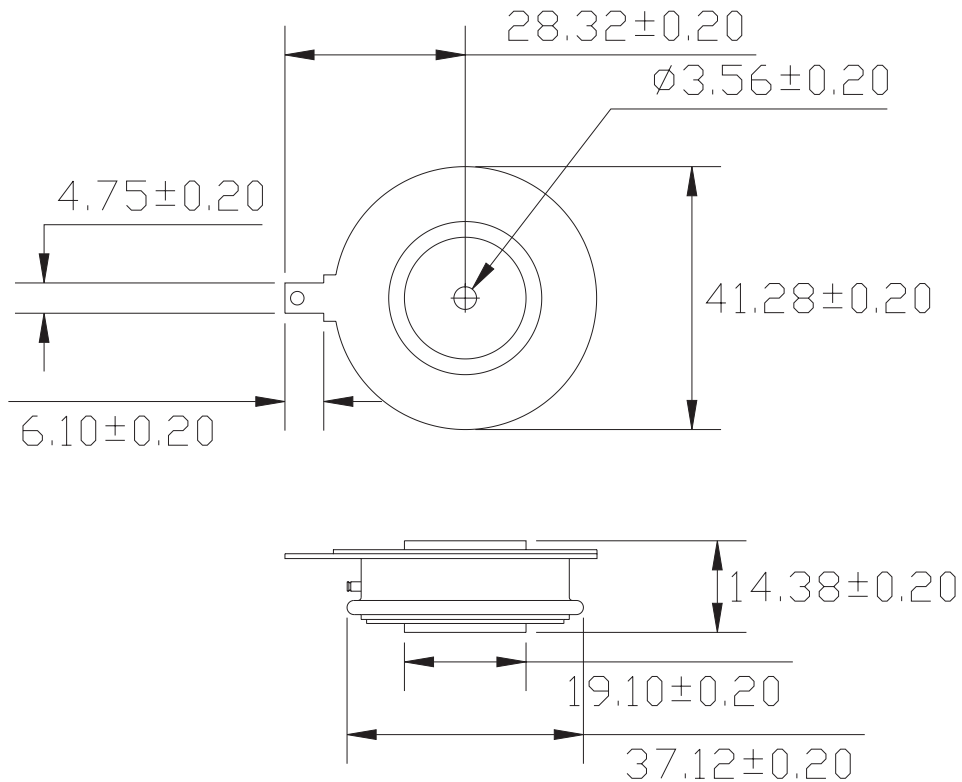

Fig. 16 - Outline Characteristics