

DATA SHEET

3R1 Material specification

Supersedes data of September 2004

2008 Sep 01

Material specification

3R1

3R1 SPECIFICATIONS

MnZn ferrite with a nearly rectangular hysteresis loop for use in magnetic regulators/amplifiers.

SYMBOL	CONDITIONS	VALUE	UNIT
μ_i	25 °C; ≤ 10 kHz; 0.25 mT	800 $\pm 20\%$	
B	25 °C; 10 kHz; 1200 A/m 100 °C; 10 kHz; 1200 A/m	≈ 410 ≈ 340	mT
B_r	from 1 kA/m; 25 °C from 1 kA/m; 100 °C	≥ 310 ≥ 220	mT
H_c	from 1 kA/m; 25 °C from 1 kA/m; 100 °C	≤ 52 ≤ 23	A/m
ρ	DC; 25 °C	$\approx 10^3$	Ωm
T_C		≥ 230	°C
density		≈ 4700	kg/m^3

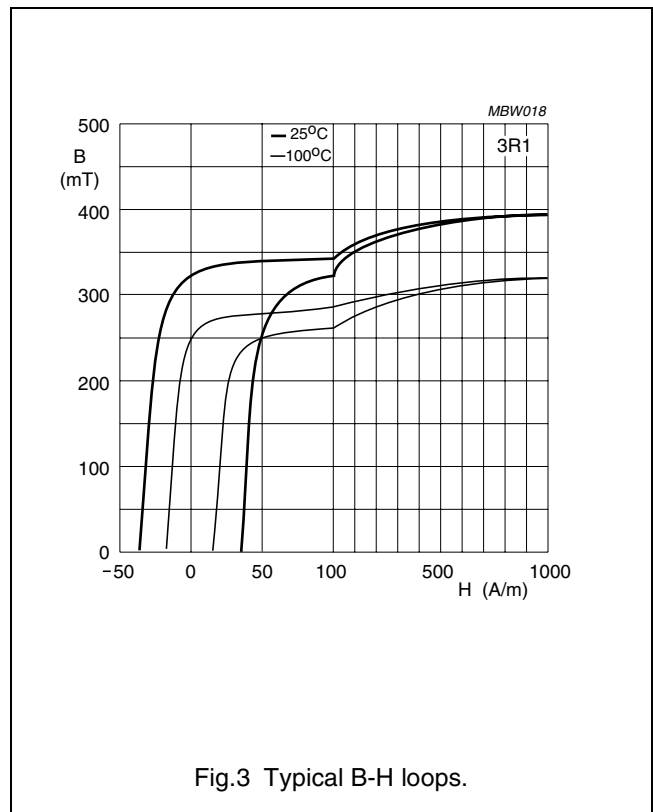
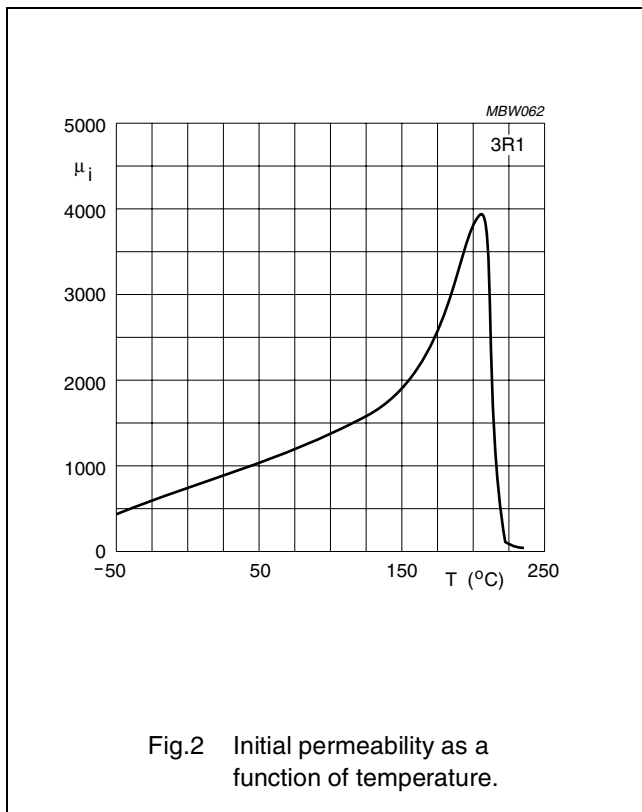
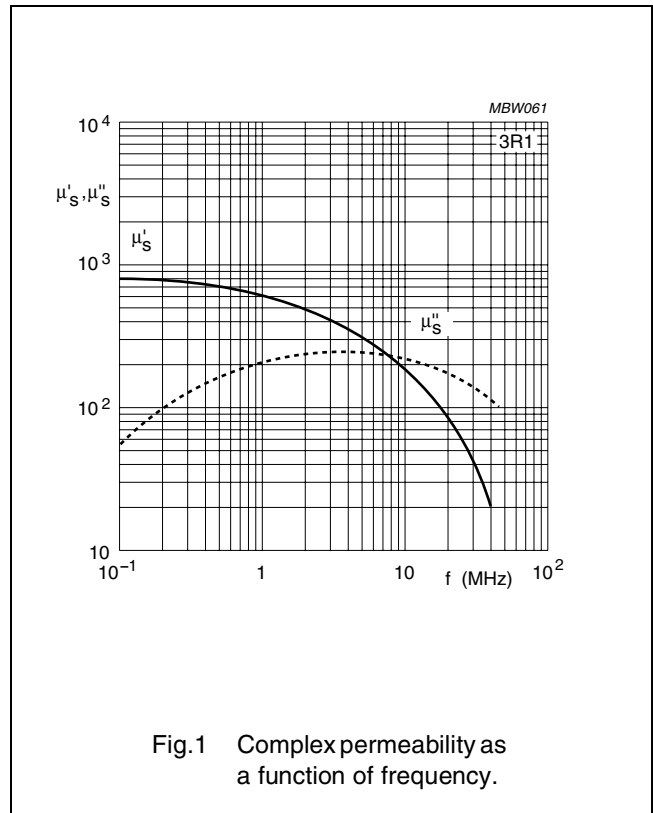

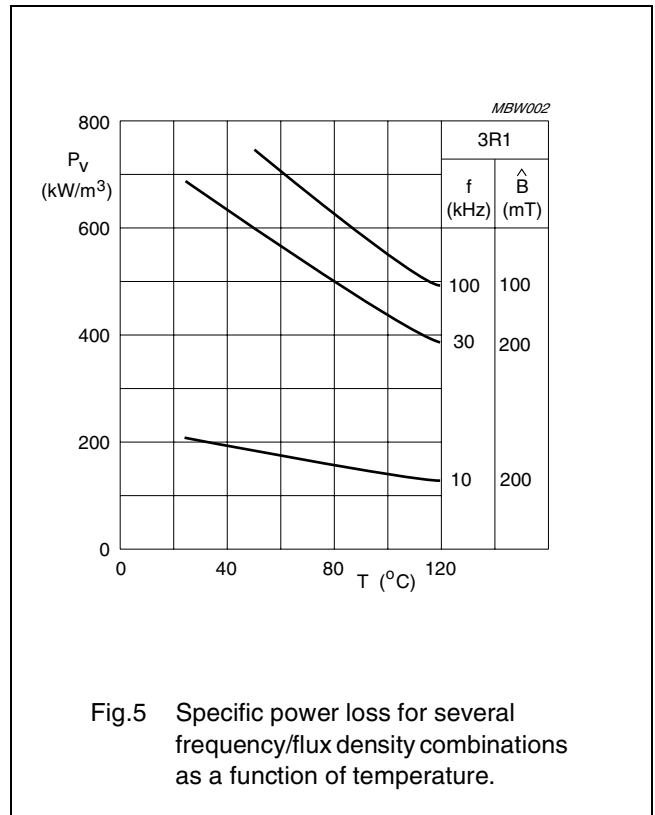
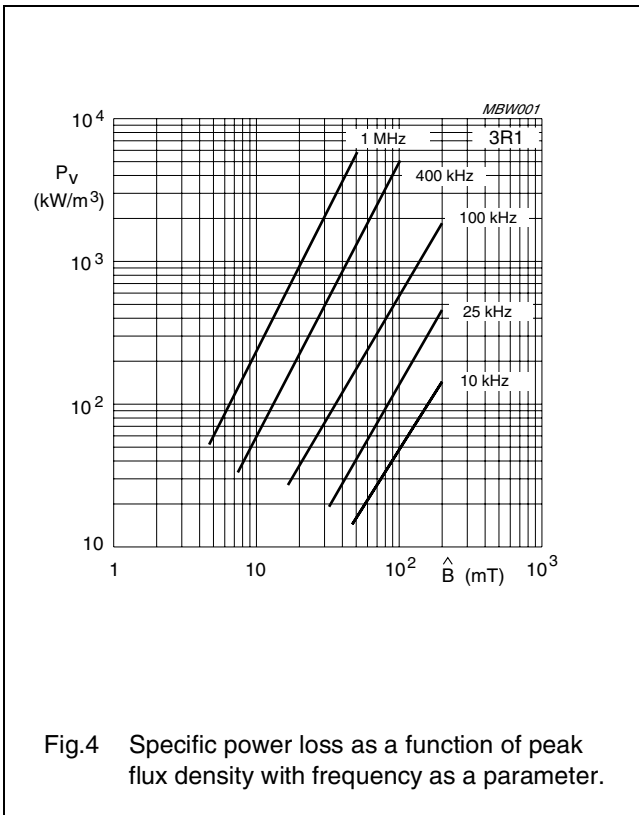

Remark:

When 3R1 ring cores are driven exactly at their natural mechanical resonant frequencies a magneto-elastic resonance will occur. With large flux excursions and no mechanical damping, amplitudes can become so high that the maximum tensile stress of the ferrite is exceeded. Cracks or even breakage of the ring core could be the result. It is advised not to drive the toroidal cores at their radial resonant frequencies or even subharmonics (e.g. half this resonant frequency).

Resonant frequencies can be calculated for any ring core with the following simple formula:

$$f_r = \frac{5700}{\pi \left(\frac{D_o + D_i}{2} \right)} \text{ kHz}$$

where:

- f = radial resonant frequency (kHz)
- D_o = outside diameter (mm)
- D_i = inside diameter (mm).

Material specification

3R1



DATA SHEET STATUS DEFINITIONS

DATA SHEET STATUS	PRODUCT STATUS	DEFINITIONS
Preliminary specification	Development	This data sheet contains preliminary data. Ferroxcube reserves the right to make changes at any time without notice in order to improve design and supply the best possible product.
Product specification	Production	This data sheet contains final specifications. Ferroxcube reserves the right to make changes at any time without notice in order to improve design and supply the best possible product.

DISCLAIMER

Life support applications — These products are not designed for use in life support appliances, devices, or systems where malfunction of these products can reasonably be expected to result in personal injury. Ferroxcube customers using or selling these products for use in such applications do so at their own risk and agree to fully indemnify Ferroxcube for any damages resulting from such application.

PRODUCT STATUS DEFINITIONS

STATUS	INDICATION	DEFINITION
Prototype		These are products that have been made as development samples for the purposes of technical evaluation only. The data for these types is provisional and is subject to change.
Design-in		These products are recommended for new designs.
Preferred		These products are recommended for use in current designs and are available via our sales channels.
Support		These products are not recommended for new designs and may not be available through all of our sales channels. Customers are advised to check for availability.