

T-52-21

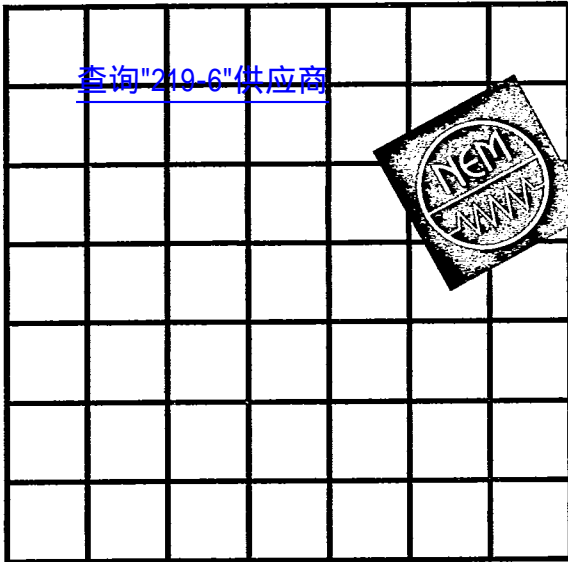

DRIVERS DEFINED

A driver is an interface between digital circuitry (TTL, ECL, etc.) and solid state RF/microwave switch circuitry. The switch usually consists of PIN/NIP diodes or Field Effect Transistors. In order to maintain high quality RF grounds, it is necessary to drive the switch elements both above and below ground potential. Hence the simplest driver contains a level translator and a bipolar current source (for PIN/NIPs) or voltage source (for FETs).

NEM DRIVERS

For higher quality, more reliable GaAs FET Switches, PIN Switches and PIN Attenuators.

Since its inception in 1981, the central focus of New England Microwave Corporation (NEM) has been to support the performance and reliability objectives of your programs with the highest quality drivers, diodes and switches.

NEM is organized into three vertically integrated business segments in order to provide you with control devices which are optimized for the best possible in-system performance characteristics. Since we manufacture our own diodes we need not settle for what others make available. NEM optimizes each component, each assembly for the best match, the best quality — consistently.

In the Driver product line, NEM specializes in the design and manufacture of hard substrate, hybrid microelectronic devices, primarily PIN/NIP diode drivers. Our ongoing research and development programs have resulted in remarkably flexible, low transient diode and FET drivers which have set the standards for small size and high speed. NEM continues to set new standards.

This brochure presents a comprehensive line of driver products; however, should special needs require a driver with characteristics seemingly not covered here, chances are we have a design which will fit. Just contact your nearest NEM Representative (see inside back cover) or our Marketing Department at the factory. 4 288

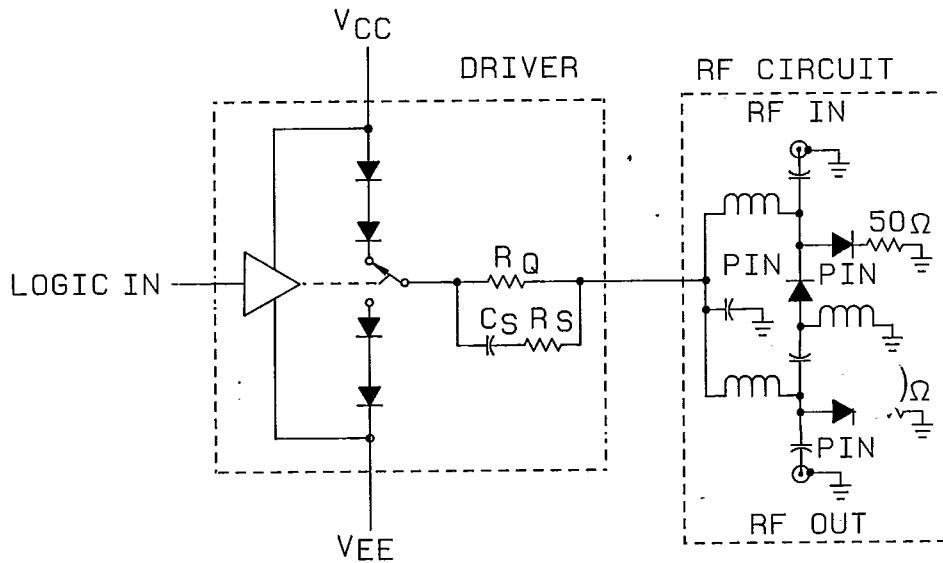

Drivers may offer additional features such as input logic functions (EXOR, decoding or latching), internal voltage regulation/protection and circuitry to improve the RF response time (spiking and active current sensing). For example, the diode driver circuit shown above features spiking circuitry (Rs and Cs).

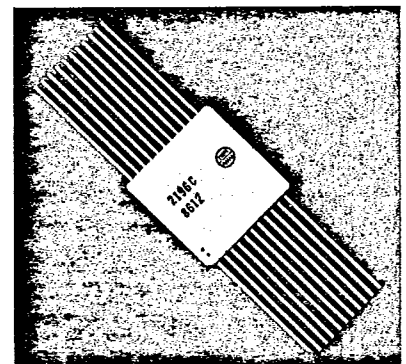

CHARACTERISTICS DEFINED

Input Logic (type) —
the particular levels that define a digital family's true and false states. NEM manufactures a wide range of TTL, ECL and CMOS compatible drivers.

Logic Sense —
an inverting (INV) driver provides a negative potential (sinking current) when its input is logical true (high, 1). A non-inverting (NONINV) driver provides a positive potential (sourcing current) when its input is logical true. An EXOR input allows the user to electrically configure the driver for inverting or non-inverting operation. The inverting/non-inverting (INV/NON) driver is configured by selecting the appropriate input pin.

Output Current —
is the typical current available from the driver's output for PIN diode biasing. Most NEM drivers produce symmetrical source (from Vcc) and sink (to Vee) currents when used as specified. Drivers that accommodate large Vee ranges produce symmetrical currents when $|V_{ee}| = V_{cc}$. See Application Notes for more details.

Spiking —
a short duration surge current delivered to the PIN diode during state transition. Its purpose is to speed up the removal of stored charge in the diode's "I" region, allowing faster switching.

Speed —
is specified as the time from 50% of the input transition to 10% or 90% of the output, terminated into a specific load. This time is the sum of delay time and rise (or fall) time. Note that the completed switch's speed is the driver's speed plus the PIN diode's switching speed. The following figure defines the conditions under which driver speed is specified.

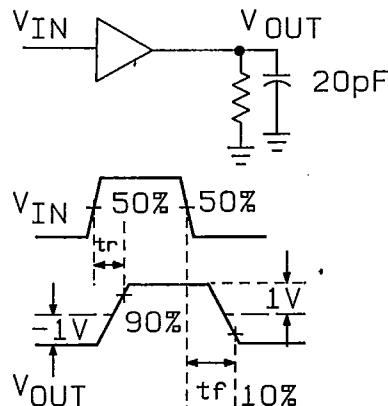

QUALITY ASSURANCE

Each NEM driver is built in accordance with a strict QA program and is subjected to a program of screening and inspection to insure delivery of the performance you expect. This program is detailed below.

OPERATION	QUANTITY SUBJECTED	MIL-STD-883 Table VIII, Class B Method
Internal Visual Inspection	100%	2017
Nondestructive Bond Pull	3 UNITS/LOT	2023
Temperature Cycling	100%	1010 Cond. B 25 cycles
Electrical Test	100%	
Gross Leak (packaged units)	100%	
External Visual (packaged units)	100%	2009

Additional MIL-STD-883 screening is available. Contact the Marketing Department at the factory for pricing.

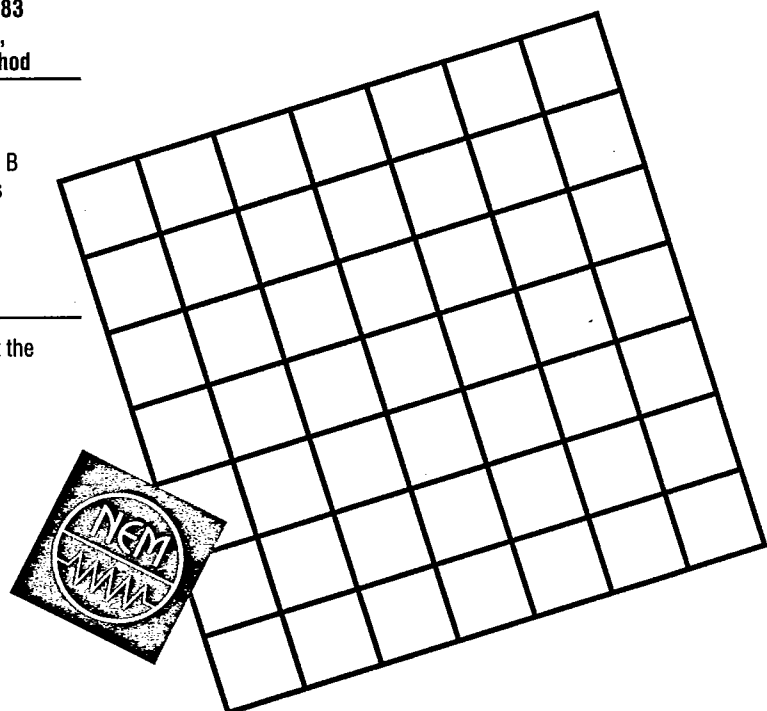

APPLICATION NOTES

查询"2100"号资料

Producing Asymmetrical Output Currents from a PIN Diode Switch Driver

To better analyze the typical switch driver, one can reduce the circuit to the simple model shown.

NOTE: with symmetrical Vcc and Vee, symmetrical source and sink output currents are available.

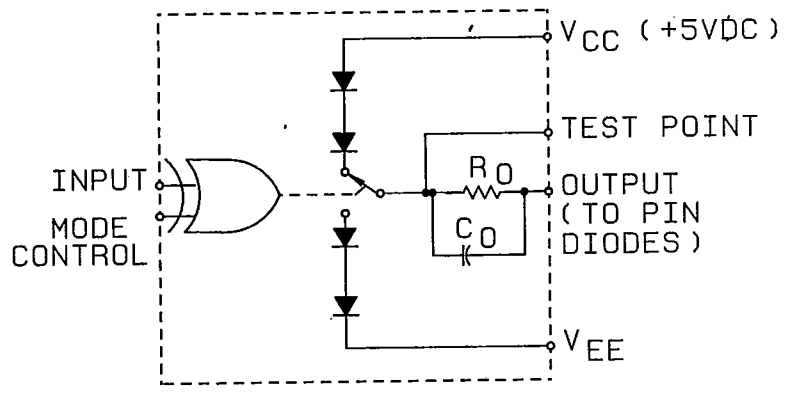

By utilizing an external current limiting structure (accessed via the test point terminal) asymmetrical output currents can be produced from symmetrical power supplies or symmetrical output currents from asymmetrical supplies.

The key to this approach is a dynamic current limiting resistor (Ro). This is achieved via a "steering" diode. The example to the right sources more current than it sinks.

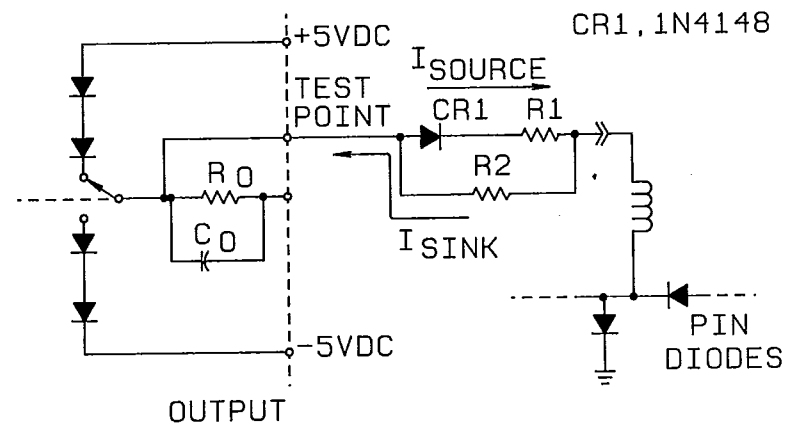

NOTE: CR1 can be reversed for higher sink than source capabilities.

$$I(SOURCE) \cong (5 - 3(V_f)) \div (R1 // R2)$$

$$I(SINK) \cong (5 - 3(V_f)) \div R2$$

Vf = DIODE FORWARD DROP

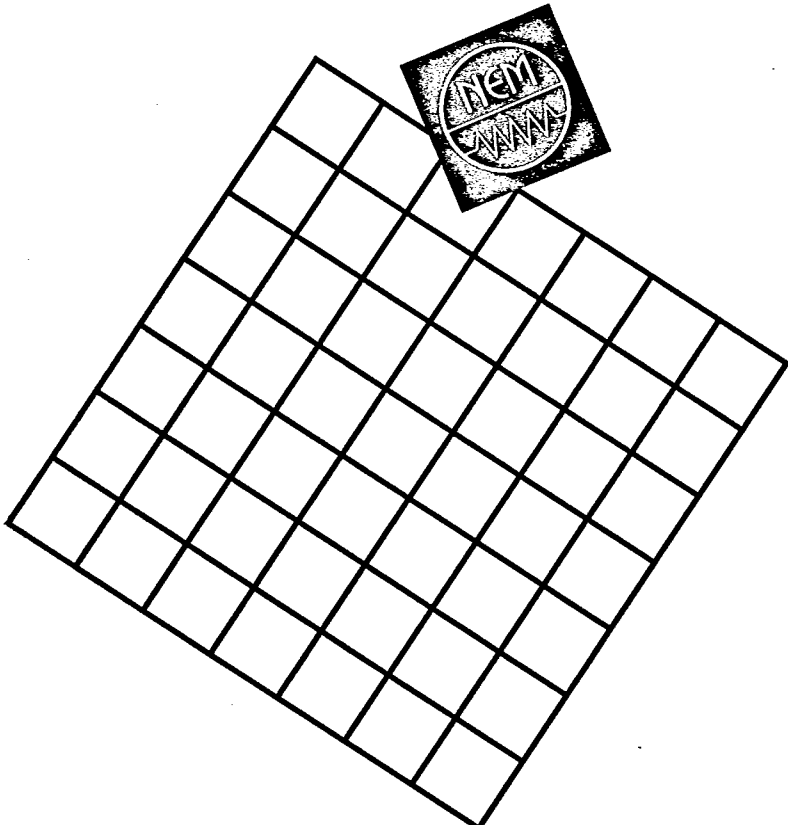

[查询"219-6"供应商](#)

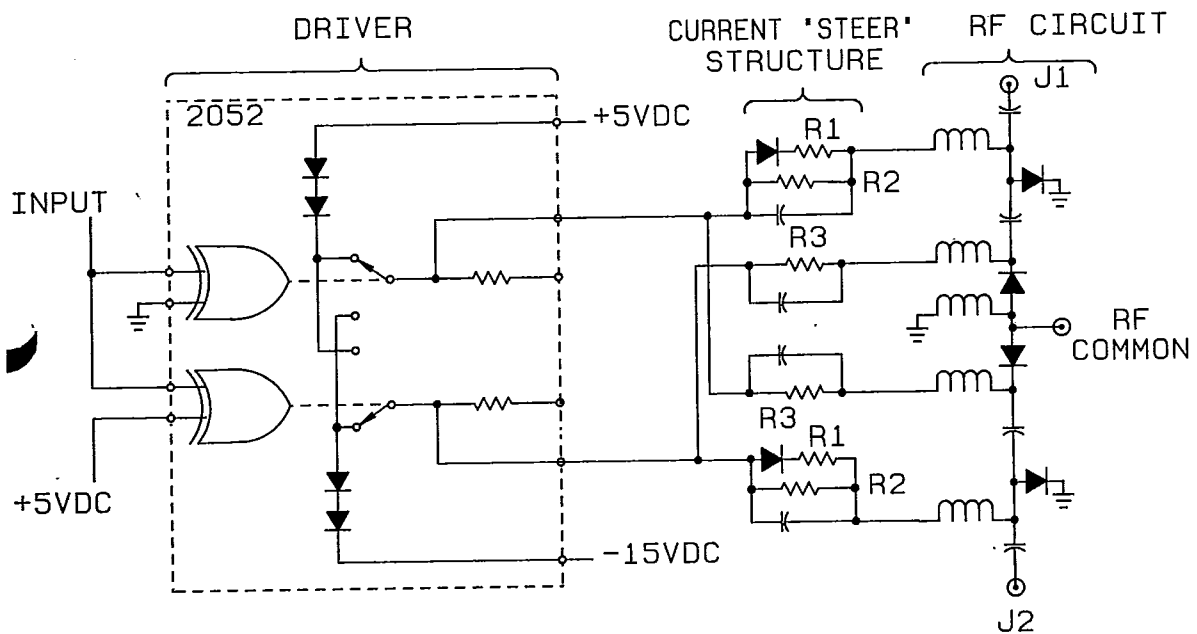
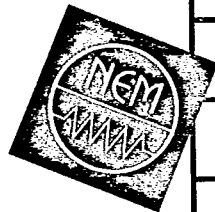
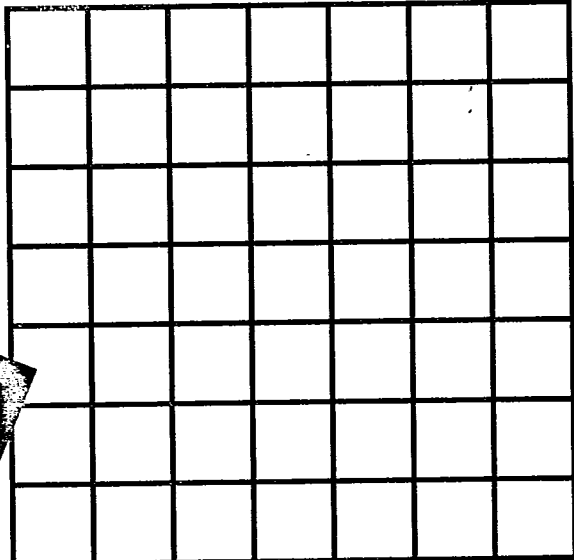

Above is an example using a NEM 2052 driver to actuate a SP2T RF PIN Diode Switch.

- I (SERIES RF DIODE) = 20 mA
- R3 = 630 ohms
- I (SHUNT RF DIODE) = 30 mA
- R1 = 60 ohms
- R2 = 560 ohms, this resistor provides reverse bias during the RF Diode's "off" state

The inputs of the driver are wired to provide out of phase outputs. Surge (spiking) capacitors "C" may be placed in parallel with the current limiting resistors (and diodes) to improve switching speed.

SPECIFICATIONS

查询"210-0"供应商
 The key selection parameters. Detailed electrical and mechanical specifications are available from the Marketing Department at the factory. The models shown here are recommended for current applications, but represent only a portion of the entire line. Information on other models is available from the factory.

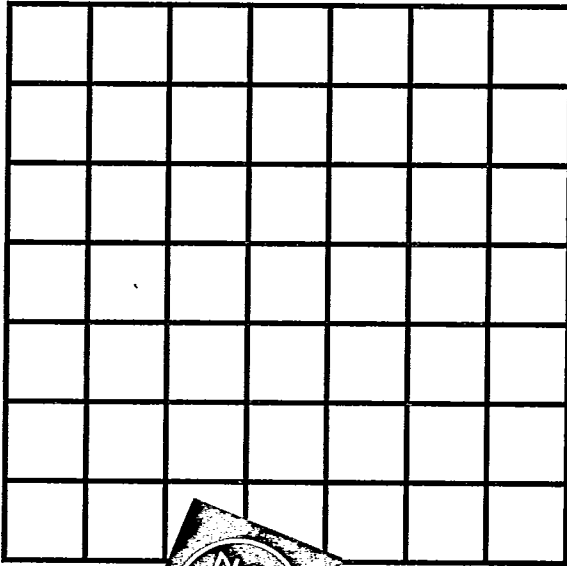

FAST TTL Input PIN Diode Drivers

MODEL #	LOGIC SENSE	CHANNELS	OUTPUTS /CHANNEL	SUPPLY VOLTAGES	OUTPUT CURRENT mA	SPEED nS	SPIKING	OUTLI
202	NONINV	1	1	+5, -12	10	6	Y	H
207	INV	1	1	+5, -5: -12	10	6	Y	H
261	INV/NON	1	1	+5, -5: -15	10	8/11	Y	H
2016	NONINV	1	1	+5, -5: -12	20	9	N	H
2052	EXOR	2	1	+5, -5: -15	20	12	Y	F

HIGH CURRENT TTL Input PIN Diode Drivers

MODEL #	LOGIC SENSE	CHANNELS	OUTPUTS /CHANNEL	SUPPLY VOLTAGES	OUTPUT CURRENT mA	SPEED nS	SPIKING	OUTLINE
218	EXOR	2	1	+5, -5: -12	20/50	70	N	B
250	INV	1	1	+5, -5: -12	35	8	Y	H
2041	NONINV	1	1	+5, -5	30	6	Y	H
2117	NONINV	1	1	+5, -5	40	9	Y	C
2118	INV	1	1	+15, -15	40	9	Y	C

MINIATURE TTL Input PIN Diode Drivers

MODEL #	LOGIC SENSE	CHANNELS	OUTPUTS /CHANNEL	SUPPLY VOLTAGES	OUTPUT CURRENT mA	SPEED nS	SPIKING	OUTLI
230CC	INV/NON	1	1	+5, -5	30	8/11	Y	E
254	INV	1	1	+5, -5	15	30	N	A

HIGH VOLTAGE TTL Input PIN Diode Drivers

MODEL #	LOGIC SENSE	CHANNELS	OUTPUTS /CHANNEL	SUPPLY VOLTAGES	OUTPUT CURRENT mA	SPEED nS	SPIKING	OUTLINE
233	INV	1	1	+5, -5: -75	10	60	Y	H
2026	---	5	CP	+5, -30	20	50	Y	J
2089	EXOR	1	1	+5, -5: -30	10	25	Y	H
2119	NONINV	1	1	+5, -5: -60	90	20	Y	G

MULTICHANNEL TTL Input PIN Diode Drivers

MODEL #	LOGIC SENSE	CHANNELS	OUTPUTS /CHANNEL	SUPPLY VOLTAGES	OUTPUT CURRENT mA	SPEED nS	SPIKING	OUTLINE
219-4	EXOR	4	1	+5, -5	50	90	N	D
219-6	EXOR	6	1	+5, -5	50	90	N	D
277	INV	4	1	+5, -5	15	50	N	B
2027	INV	6	1	+5, -5	10	75	N	D
2054	EXOR	4	1	+5, -5: -15	20	12	Y	D
2056	EXOR	6	1	+5, -5: -15	20	12	Y	K

ECL Input PIN Diode Drivers

查询"219-6"供应商

JDEL #	LOGIC SENSE	CHANNELS	OUTPUTS /CHANNEL	SUPPLY VOLTAGES	OUTPUT CURRENT mA	SPEED nS	SPIKING	OUTLINE
238	BAL	1	CP	+5, -5.2	3	3	Y	B
2110	BAL/SE	1	2	+5, -5.2	5/15/40	2	Y	B

/ denotes selectable feature
 CP = complementary pair
 BAL = balanced line
 SE = single ended

RF Field Effect Transistor Driver

MODEL #	LOGIC SENSE	CHANNELS	OUTPUTS /CHANNEL	SUPPLY VOLTAGES	OUTPUT VOLTAGES	SPEED nS	OUTLINE
2120	ECL	1	CP	+5, -5.2	0, -5	4	---
2121	TTL	1	CP	+5, -10: -20	0, -8	5	---

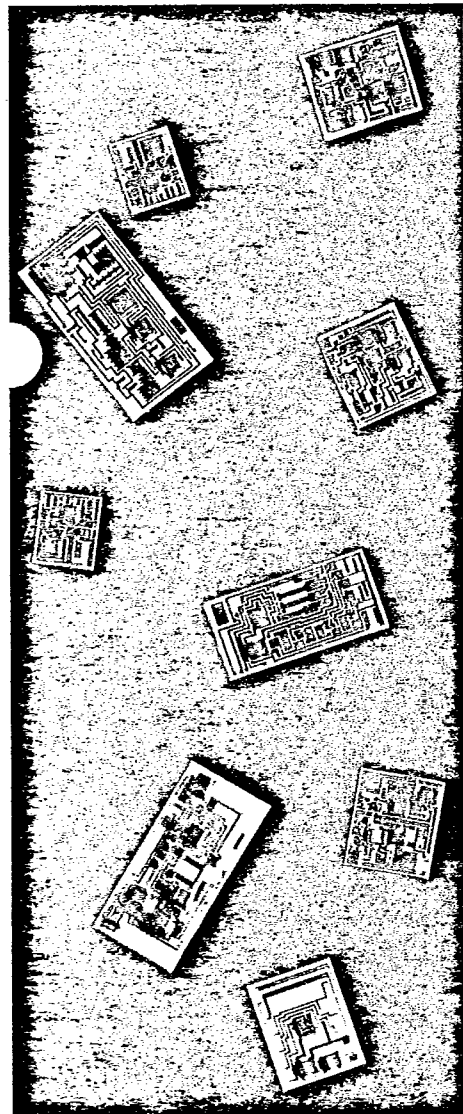

SUBSTRATES

NEM drivers are also available in unpackaged substrate form. These units can be mounted into your switch assembly, giving you the ability to miniaturize the complete switch package. These substrate drivers are electrically connected via wire bonds. Some models may also accommodate soldered connections. Consult your NEM Representative or the factory for specific application information.

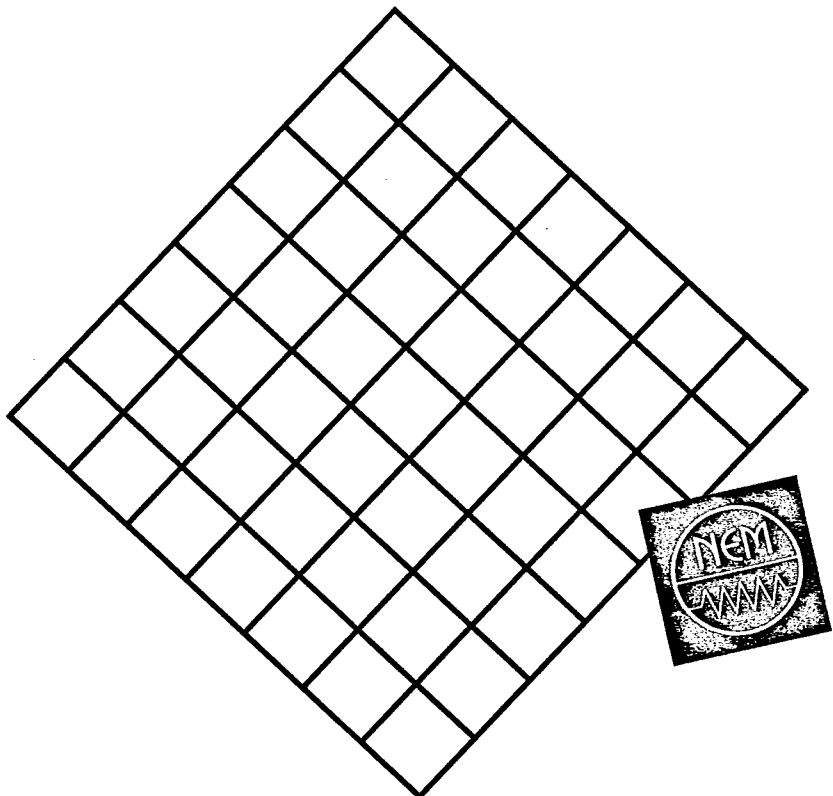

PACKAGE OUTLINES

[查询"219-6"供应商](#)

T-52-21

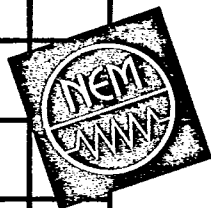
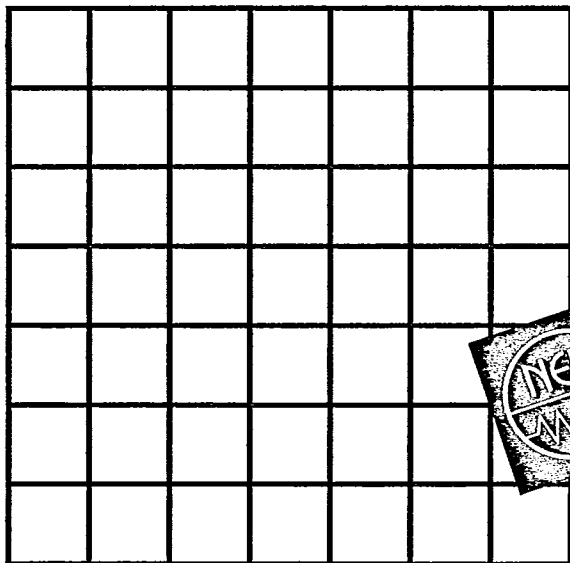
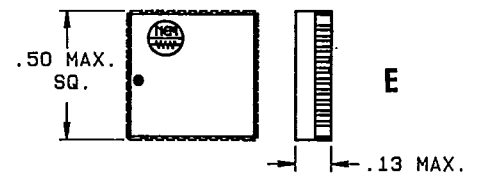
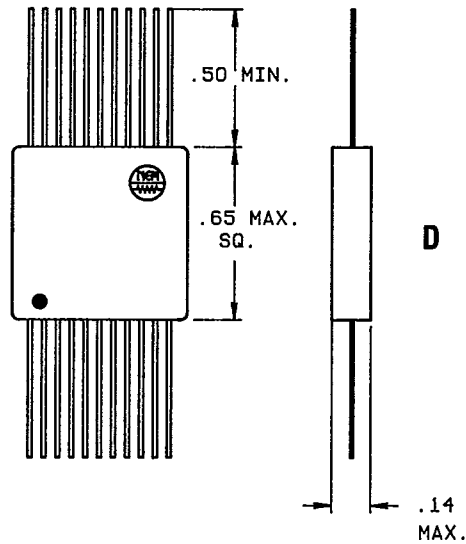
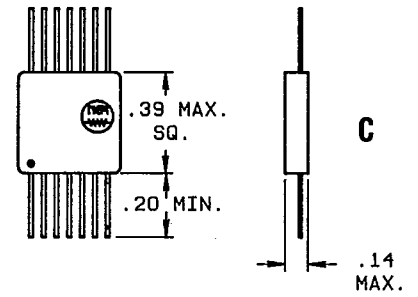
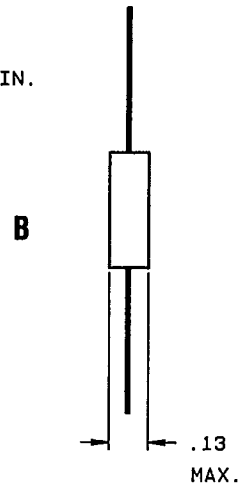
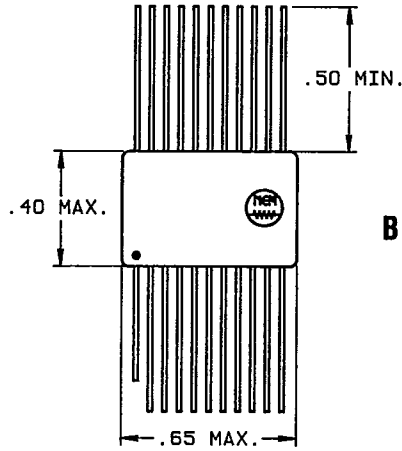
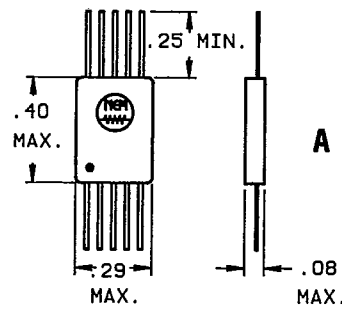

查询 219-6 供应商

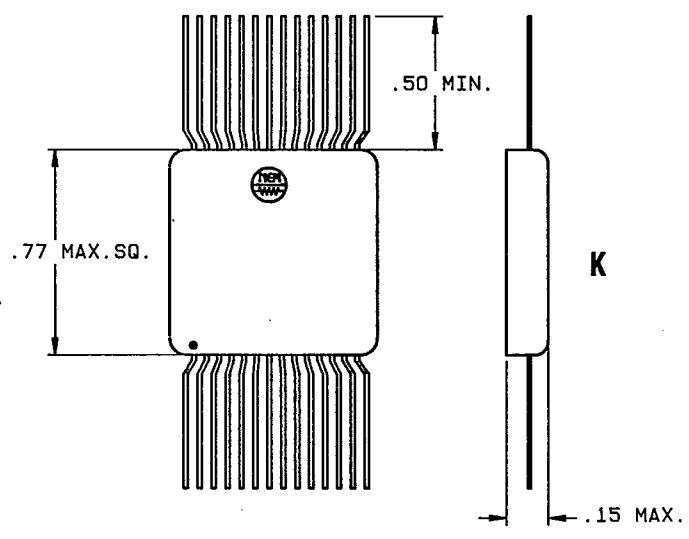
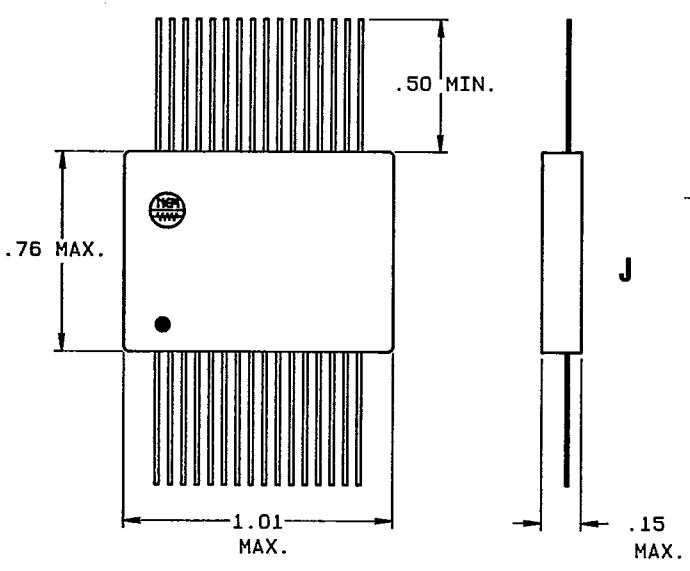
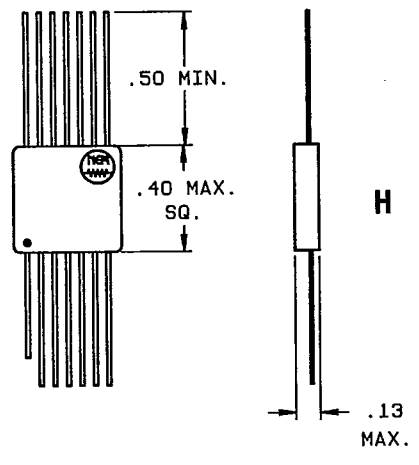
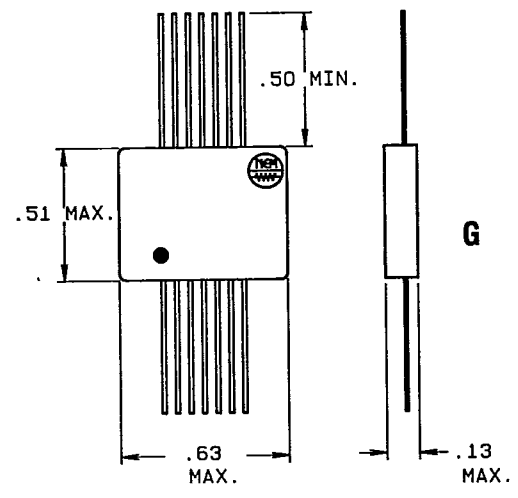
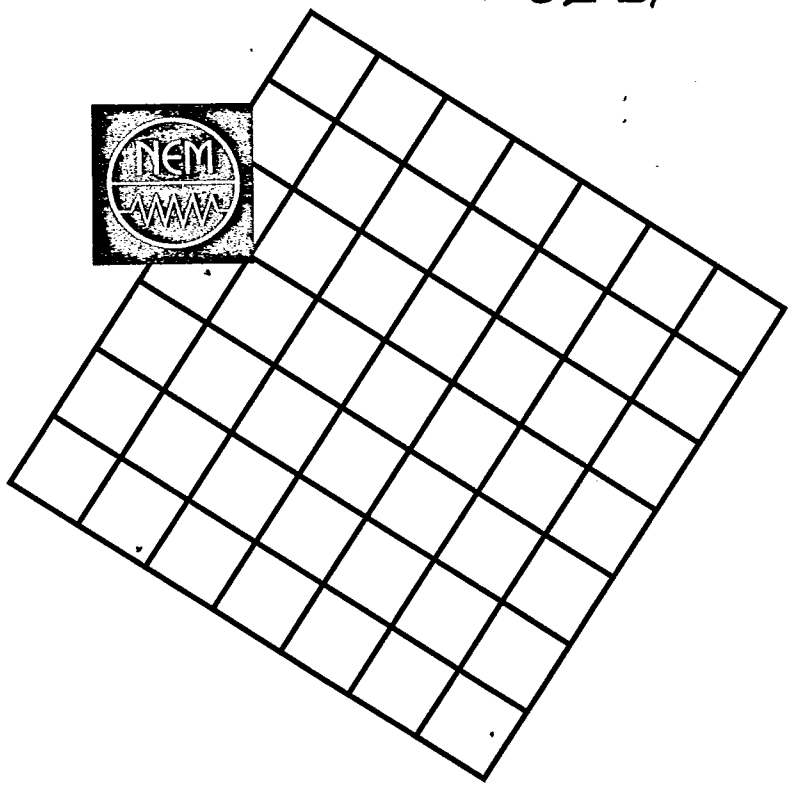
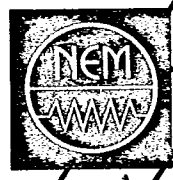
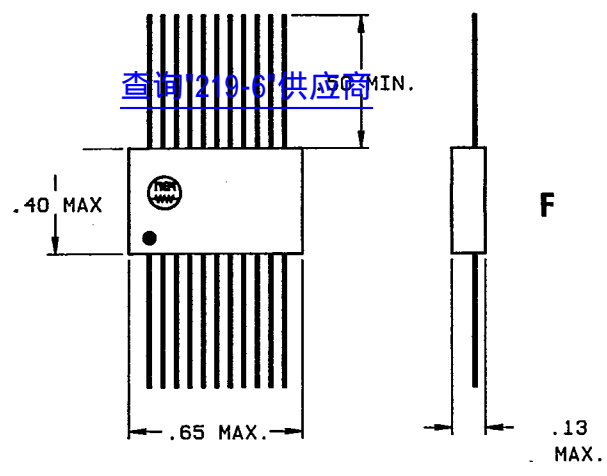

[查询"219-6"供应商](#)

CONSTRUCTION FEATURES

NEM drivers are manufactured in an ESD-protected clean room. Fabricated on alumina substrates, each NEM driver features laser trimmed sputtered nichrome thin film resistors. Circuit paths and attachment areas are gold plated (MIL-G-45202, Type III, Class 2). Semiconductor devices are attached via electrically conductive

epoxies. Hybrid interconnections are made through aluminum wire bonds. The driver substrate is installed into a Kovar housing using a thermally conductive epoxy. The sealed housing features glassed-in feedthru pins and a seam-welded cover. Ceramic housings are available for selected models.

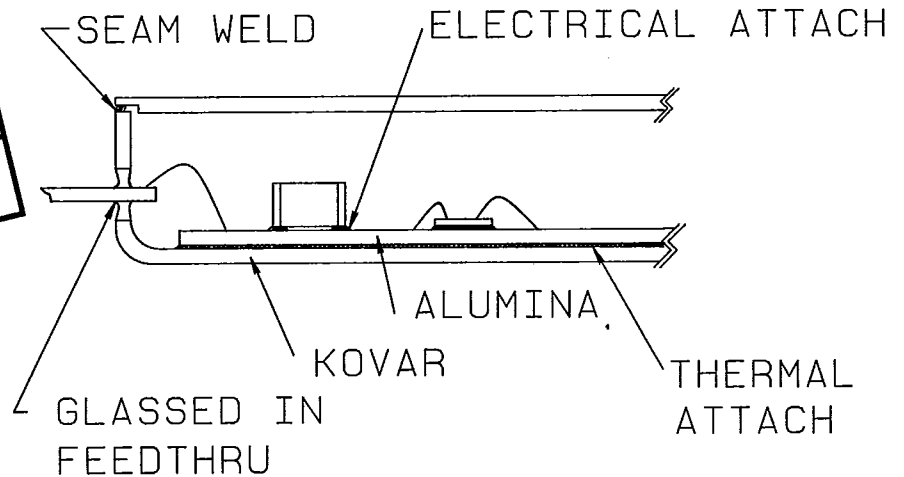
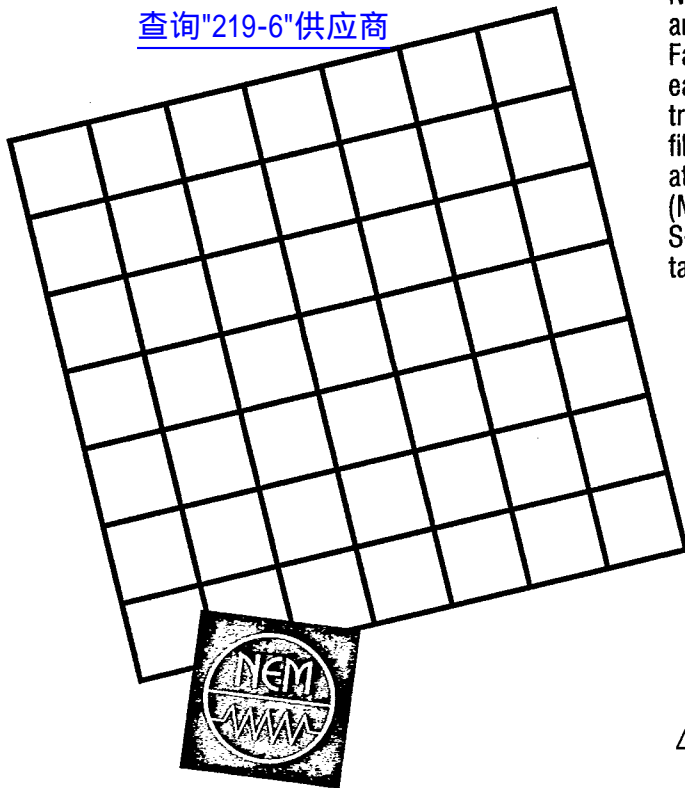

INSTALLATION

NEM flatpack drivers are intended for installation into printed wiring assemblies. Electrical connections can be made with solder or wire bonding techniques. For high-power drivers or high operating temperature situations, "heat sinking" is required. This can be accomplished by planar contact between the driver's bottom surface and the chassis or heat sink. Use of thermally conductive greases will aid heat transfer.

Metal flatpacks may also be mounted, or "sandwiched", between two heat sink surfaces, top and bottom, for maximum heat transfer.

NEM Leadless Chip Carrier drivers are intended for reflow soldering or similar surface mount techniques. Ceramic housings should not be used in mounting schemes that involve compressive forces.

