

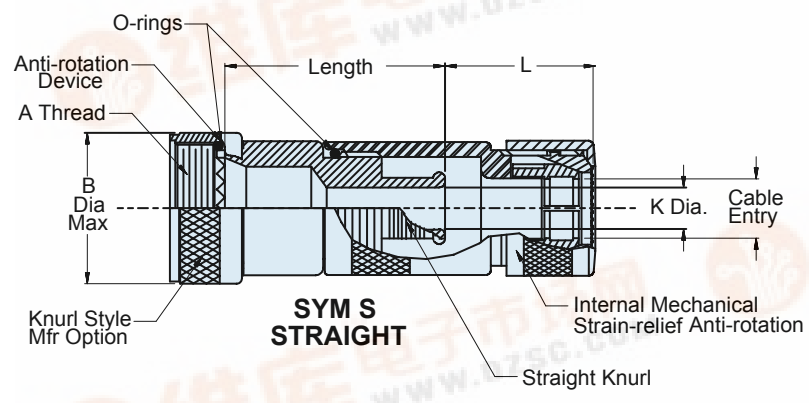

查询"189HS016M1707-3B"供应商

**189-016**  
**Backshell with Banding Strain Relief**  
**Environmental Resistant**  
**for MIL-DTL-38999 Series III Fiber Optic Connectors**

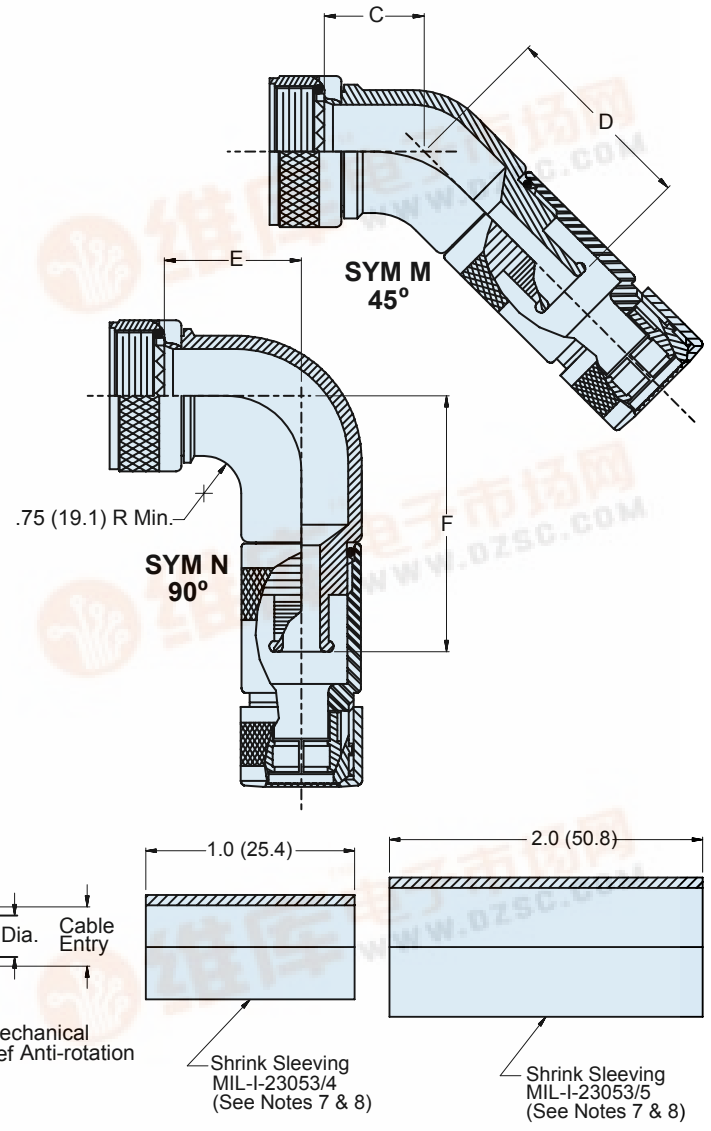
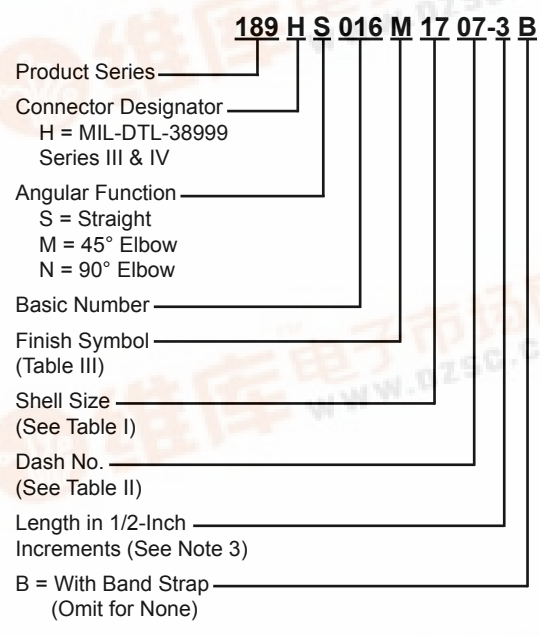

**APPLICATION NOTES**

1. Assembly to be identified with manufacturer's name and P/N as space permits.
2. Glenair 600 series Backshell assembly tools are recommended for assembly and installation.
3. Standard minimum length: 1.5 inches, for shorter length consult factory.
4. Material/ Finish:  
Adapter, Coupling Nut- Alloy/ See Table III.  
Clamp components- Ryton R4XT- Black, Ultem 1000-Natural  
Anti- Rotation device Torlon 4203L- Natural.
5. For shield termination see Glenair drawings 600-050 & 600-052.
6. Consult factory for larger cable size.
7. MIL-I-23053/4 Shrink Sleeve to be packaged loose in a plastic bag.
8. MIL-I-23053/4 Shrink Sleeve to be heat shrink over rear of adapter before MIL-I-23053/5 Shrink Sleeve.
9. Metric dimensions (mm) are indicated in parentheses.



189-016

Backshell with Banding Strain Relief  
Environmental Resistant  
for MIL-DTL-38999 Series III Fiber Optic Connectors



Backshells and  
Accessories

TABLE I: SHELL SIZE

Shell Size	A Thread ISO Metric	B Max	C Max	D Max	E Max	F Max	Dash No. Max
11	M15 x 1 - 6H	.890 (22.6)	.861 (21.9)	1.111 (28.2)	1.563 (39.7)	1.875 (47.6)	05
13	M18 x 1 - 6H	1.020 (25.9)	.911 (23.1)	1.161 (29.5)	1.938 (49.2)	2.250 (57.2)	05
15	M22 x 1 - 6H	1.150 (29.2)	.965 (24.5)	1.215 (30.9)	1.938 (49.2)	2.250 (57.2)	07
17	M25 x 1 - 6H	1.230 (31.2)	1.014 (25.8)	1.264 (32.1)	2.063 (52.4)	2.375 (60.3)	07
19	M28 x 1 - 6H	1.360 (34.5)	1.064 (27.0)	1.314 (33.4)	2.063 (52.4)	2.375 (60.3)	09
21	M31 x 1 - 6H	1.480 (37.6)	1.118 (28.4)	1.368 (34.7)	2.563 (65.1)	2.875 (73.0)	11
23	M34 x 1 - 6H	1.600 (40.6)	1.172 (29.8)	1.422 (36.1)	2.313 (58.8)	2.688 (68.3)	11
25	M37 x 1 - 6H	1.730 (43.9)	1.221 (31.0)	1.471 (37.4)	2.250 (57.2)	2.563 (65.1)	13

TABLE II: DASH NUMBER AND CABLE ENTRY

Dash No.	Clamp Size	Max Cable Size	K Dia ±.005 (0.1)	L Max	MIL-I-23053/4 Shrink Sleeve	MIL-I-23053/3 Shrink Sleeve	Cable Entry* Min	Max
05	12	.280 (7.1)	.312 (8.0)	1.110 (28.2)	/4-203-0	/5-107-0	.233 (6.0)	.375 (9.5)
07	16	.395 (10.0)	.438 (11.1)	1.210 (30.7)	/4-204-0	/5-108-0	.358 (9.1)	.500 (12.7)
09	20	.510 (13.0)	.562 (14.3)	1.210 (30.7)	/4-204-0	/5-109-0	.482 (12.2)	.625 (15.9)
11	24	.621 (15.8)	.688 (17.5)	1.210 (30.7)	/4-205-0	/5-109-0	.545 (13.8)	.750 (19.1)
13	28	.736 (18.7)	.812 (20.6)	1.360 (34.5)	/4-205-0	/5-110-0	.670 (17.0)	.875 (22.2)
15	32	.851 (21.6)	.938 (23.8)	1.510 (38.4)	/4-206-0	/5-111-0	.795 (20.2)	1.000 (25.4)
17	36	.966 (24.5)	1.062 (27.0)	1.510 (38.4)	/4-206-0	/5-107-0	1.014 (25.8)	1.250 (31.8)
19	40	1.091 (27.7)	1.188 (30.2)	1.510 (38.4)	/4-206-0	/5-111-0	1.014 (25.8)	

\*See Note 5

TABLE III: FINISH

SYM	MATERIAL	FINISH
NF	Aluminum	Cadmium/Olive Drab over Electroless Nickel (500 Hr. Salt Spray)
B	Aluminum	Cadmium Plate/Olive Drab
J	Aluminum	Gold Iridite over Cadmium Plate over Nickel
N	Aluminum	Cadmium Plate/Olive Drab over Nickel
M	Aluminum	Electroless Nickel
T	Aluminum	Cadmium Plate/Bright Dip over Nickel