



EVERLIGHT ELECTRONICS CO.,LTD.

DATA SHEET

PART NO. : 383-2UBGC/S400-A5

DATE : 2005/8/8

DEPARTMENT : CHR&D1

REVISION : 2

| | | | |
|---|----------|--------------|----------|
| RECEIVED | | | |
| <input checked="" type="checkbox"/> MASS PRODUCTION | | | |
| <input type="checkbox"/> PRELIMINARY | | | |
| <input type="checkbox"/> CUSTOMER DESIGN | | | |
| DEVICE NUMBER : | | CDLE-038-214 | |
| PAGE : | | 6 | |
| CUSTOMER | DESIGNER | CHECKER | APPROVER |
| | | | |

| REV. | DESCRIPTION | RELEASE DATE |
|------|-------------|--------------|
| | | |
| | | |
| | | |
| | | |

OFFICE: 7C BUILDING, LIAN HUA PORT INDUSTRIAL DISTRICT, LIAN HUA SHAN

BONDED PRICESSING ZONE PAN YU, GUANG ZHU, CHINA

TEL. : (020)84860913,84860914

FAX : (020)84860600

[http : //www.everlight.com](http://www.everlight.com)



Technical Data Sheet

5.0mm Round Type LED Lamps

383-2UBGC/S400-A5

■ Features :

- Choice of various viewing angles
- Available on tape and reel.
- Reliable and robust
- Pb free
- The product itself will remain within RoHS compliant version.



■ Descriptions :

- The series is specially designed for applications requiring higher brightness
- The led lamps are available with different colors, intensities,

■ Applications :

- TV set
- Monitor
- Telephone
- Computer

| PART NO. | Material | Emitted Color | Lens Color |
|-------------------|-----------|---------------|-------------|
| 383-2UBGC/S400-A5 | InGaN/SiC | Super Blue | Water Clear |

5.0mm Round Type LED Lamps

383-2UBGC/S400-A5

Package Dimensions

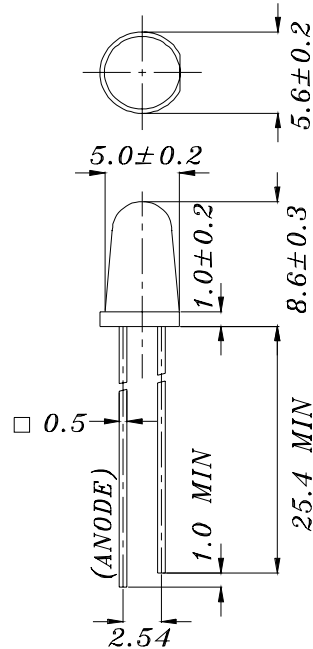

Notes: 1. All dimensions are in millimetres

2. An epoxy meniscus may extend about 1.5mm(0.059") down to the lead.

3. Tolerances unless Dimension ± 0.25 mm.

Absolute Maximum Ratings at $T_a = 25^\circ\text{C}$

| Parameter | Symbol | Rating | Unit |
|-------------------------|--------------------|-------------|------------------|
| Forward Current | I_F | 30 | mA |
| Operating Temperature | T_{opr} | -40 to +85 | $^\circ\text{C}$ |
| Storage Temperature | T_{stg} | -40 to +100 | $^\circ\text{C}$ |
| Electrostatic Discharge | ESD | 1000 | V |
| Soldering Temperature | T_{sol} | 260 ± 5 | $^\circ\text{C}$ |
| Power Dissipation | P_d | 120 | mW |
| Peak Forward Current | $I_F(\text{Peak})$ | 100 | mA |
| Reverse Voltage | V_R | 5 | V |

Note: *1: I_{FP} Conditions --Pulse Width $\leq 1\text{msec}$ and Duty $\leq 1/10$.

*2: Soldering time ≤ 5 seconds.



Technical Data Sheet
5.0mm Round Type LED Lamps

383-2UBGC/S400-A5

Electro-Optical Characteristics (Ta=25°C)

| Parameter | Symbol | Condition | Min. | Typ. | Max. | Unit |
|------------------------------|----------------|------------------------|------|------|------|------|
| Forward Voltage | V _F | I _F = 20 mA | / | 3.5 | 4.3 | V |
| Reverse Current | I _R | V _R = 5 V | / | / | 50 | μA |
| Luminous Intensity | I _v | I _F = 20 mA | 4000 | 6300 | / | mcd |
| Viewing Angle | 2θ 1/2 | I _F = 20 mA | / | 6 | / | deg |
| Peak Wavelength | λ _p | I _F = 20 mA | / | 502 | / | nm |
| Dominant Wavelength | λ _d | I _F = 20 mA | / | 505 | / | nm |
| Spectrum Radiation Bandwidth | Δλ | I _F = 20 mA | / | 30 | / | nm |



查询"383-2UBGC-S400-A5"供应商

Technical Data Sheet

5.0mm Round Type LED Lamps

383-2UBGC/S400-A5

Typical Electro-Optical Characteristic Curves:

(UBG)

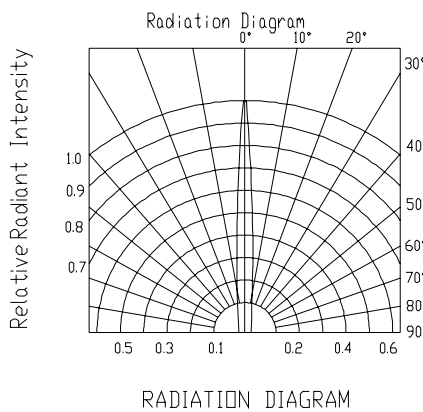
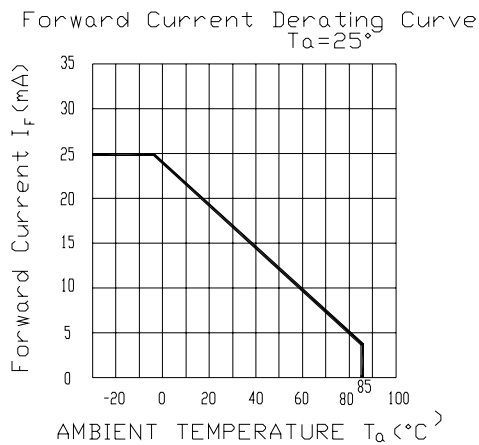
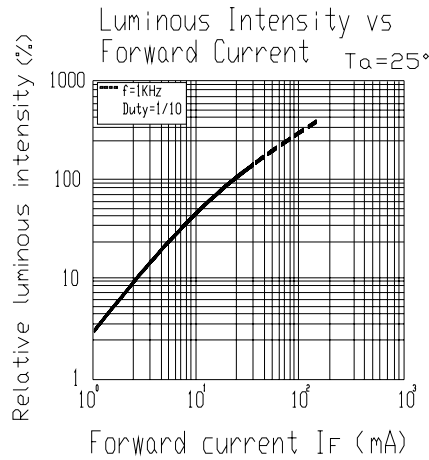
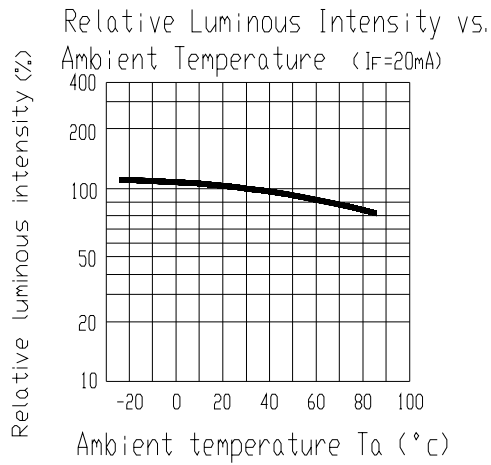
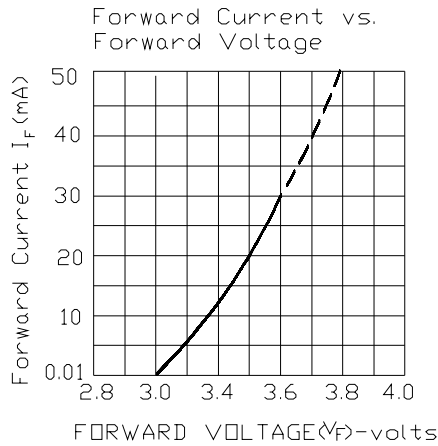
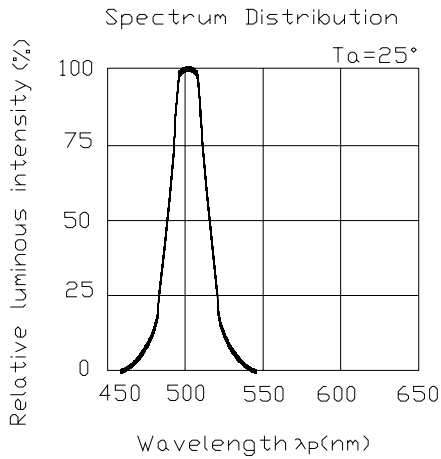



Technical Data Sheet

5.0mm Round Type LED Lamps

383-2UBGC/S400-A5

■ Reliability test items and conditions:

| NO | Item | Test Conditions | Test Hours/Cycle | Sample size | Ac/Re |
|----|----------------------------------|--|------------------|-------------|-------|
| 1 | Solder Heat | TEMP : 260°C ± 5 °C | 10 SEC | 76 PCS | 0/1 |
| 2 | Temperature Cycle | H : +100°C 15min ∫ 5 min L : -40°C 15min | 300 CYCLES | 76 PCS | 0/1 |
| 3 | Thermal Shock | H : +100°C 5min ∫ 10 sec L : -10°C 5min | 300 CYCLES | 76 PCS | 0/1 |
| 4 | High Temperature Storage | TEMP : 100°C | 1000 HRS | 76 PCS | 0/1 |
| 5 | Low Temperature Storage | TEMP : -40°C | 1000 HRS | 76 PCS | 0/1 |
| 6 | DC Operating Life | TEMP : 25°C IF = 20mA | 1000 HRS | 76 PCS | 0/1 |
| 7 | High Temperature / High Humidity | 85°C / 85% RH | 1000 HRS | 76 PCS | 0/1 |



Technical Data Sheet

5.0mm Round Type LED Lamps

383-2UBGC/S400-A5

Packing Quantity Specification

1.500PCS/1Bag , 5Bags/1Box

2.10Boxes/1Carton

Label Form Specification

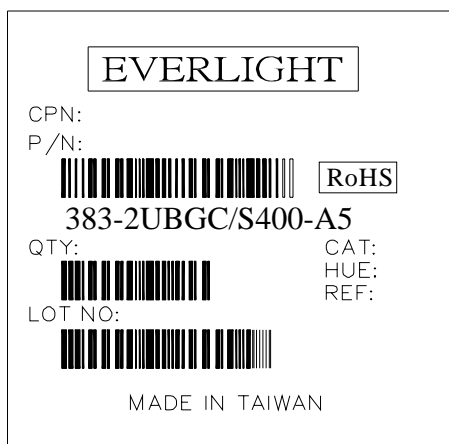

CPN: Customer's Production Number

P/N : Production Number

QTY: Packing Quantity

CAT: Ranks

HUE: Peak Wavelength

REF: Reference

LOT No: Lot Number

MADE IN TAIWAN: Production Place

Notes

1. Above specification may be changed without notice. EVERLIGHT will reserve authority on material change for above specification.
2. When using this product, please observe the absolute maximum ratings and the instructions for using outlined in these specification sheets. EVERLIGHT assumes no responsibility for any damage resulting from use of the product which does not comply with the absolute maximum ratings and the instructions included in these specification sheets.
3. These specification sheets include materials protected under copyright of EVERLIGHT corporation. Please don't reproduce or cause anyone to reproduce them without EVERLIGHT's consent.

EVERLIGHT ELECTRONICS CO., LTD.

Office: No 25, Lane 76, Sec 3, Chung Yang Rd,
Tucheng, Taipei 236, Taiwan, R.O.C

Tel: 886-2-2267-2000, 2267-9936

Fax: 886-2267-6244, 2267-6189, 2267-6306
<http://www.everlight.com>