

[查询"74AVC16835ADGV"供应商](#)

# DATA SHEET

## **74AVC16835A**

18-bit registered driver with Dynamic  
Controlled Outputs™ (3-State)

Product data  
Supersedes data of 2000 Jul 25

2002 Mar 15

# 18-bit registered driver with Dynamic Controlled Outputs™ (3-State)

74AVC16835A

## FEATURES

- Wide supply voltage range of 1.2 V to 3.6 V
- Complies with JEDEC standard no. 8-1A/5/7
- CMOS low power consumption
- Input/output tolerant up to 3.6 V
- DCO (Dynamic Controlled Output) circuit dynamically changes output impedance, resulting in noise reduction without speed degradation
- Low inductance multiple  $V_{CC}$  and GND pins for minimum noise and ground bounce
- Power off disables 74AVC16835A outputs, permitting Live Insertion
- Integrated input diodes to minimize input overshoot and undershoot
- Full PC133 solution provided when used with PCK2509S or PCK2510S and CBT16292

## DESCRIPTION

The 74AVC16835A is a 18-bit universal bus driver. Data flow is controlled by output enable (OE), latch enable (LE) and clock inputs (CP).

This product is designed to have an extremely fast propagation delay and a minimum amount of power consumption.

To ensure the high-impedance state during power up or power down, OE should be tied to  $V_{CC}$  through a pullup resistor (Live Insertion).

A Dynamic Controlled Output (DCO) circuitry is implemented to support termination line drive during transient. See the graphs on page 8 for typical curves.

## PIN CONFIGURATION

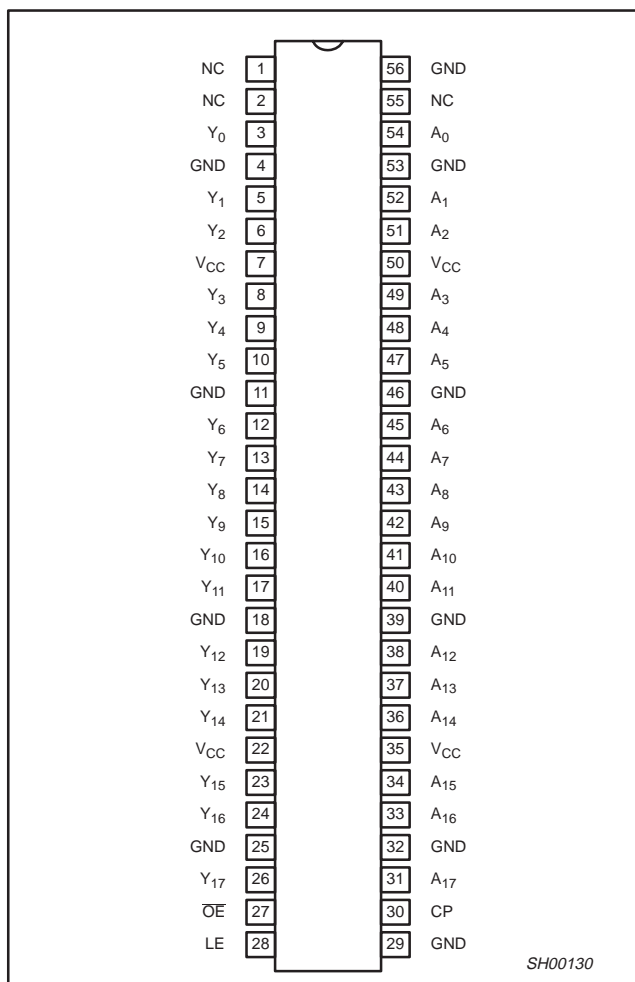

## QUICK REFERENCE DATA

GND = 0 V;  $T_{amb} = 25^{\circ}\text{C}$ ;  $t_r = t_f \leq 2.0$  ns;  $C_L = 30$  pF.

SYMBOL	PARAMETER	CONDITIONS	TYPICAL	UNIT
$t_{PHL}/t_{PLH}$	Propagation delay An to Yn	$V_{CC} = 1.8$ V $V_{CC} = 2.5$ V $V_{CC} = 3.3$ V	2.1 1.7 1.5	ns
$t_{PHL}/t_{PLH}$	Propagation delay LE to Yn; CP to Yn	$V_{CC} = 1.8$ V $V_{CC} = 2.5$ V $V_{CC} = 3.3$ V	2.2 1.9 1.7	ns
$C_I$	Input capacitance		3.8	pF
$C_{PD}$	Power dissipation capacitance per buffer	$V_I = \text{GND to } V_{CC}^1$	Outputs enabled Output disabled	25 6
				pF

### NOTE:

1.  $C_{PD}$  is used to determine the dynamic power dissipation ( $P_D$  in  $\mu\text{W}$ ):

$$P_D = C_{PD} \times V_{CC}^2 \times f_i + \sum (C_L \times V_{CC}^2 \times f_o) \text{ where: } f_i = \text{input frequency in MHz; } C_L = \text{output load capacitance in pF; } f_o = \text{output frequency in MHz; } V_{CC} = \text{supply voltage in V; } \sum (C_L \times V_{CC}^2 \times f_o) = \text{sum of outputs.}$$

## ORDERING INFORMATION

PACKAGES	TEMPERATURE RANGE	ORDER CODE	DRAWING NUMBER
56-Pin Plastic 0.5 mm pitch TSSOP	-40 to +85 $^{\circ}\text{C}$	74AVC16835ADGG	SOT364-1
56-Pin Plastic 0.4 mm pitch TSSOP (TVSOP)	-40 to +85 $^{\circ}\text{C}$	74AVC16835ADGV	SOT481-2

# 18-bit registered driver with Dynamic Controlled Outputs™ (3-State)

74AVC16835A

## PIN DESCRIPTION

PIN NUMBER	SYMBOL	NAME AND FUNCTION
1, 2, 55	NC	No connection
3, 5, 6, 8, 9, 10, 12, 13, 14, 15, 16, 17, 19, 20, 21, 23, 24, 26	Y <sub>0</sub> to Y <sub>17</sub>	Data outputs
4, 11, 18, 25, 32, 39, 46, 53, 56	GND	Ground (0V)
7, 22, 35, 50	V <sub>CC</sub>	Positive supply voltage
27	OE	Output enable input (active LOW)
28	LE	Latch enable input (active HIGH)
30	CP	Clock input
54, 52, 51, 49, 48, 47, 45, 44, 43, 42, 41, 40, 38, 37, 36, 34, 33, 31	A <sub>0</sub> to A <sub>17</sub>	Data inputs

## LOGIC SYMBOL

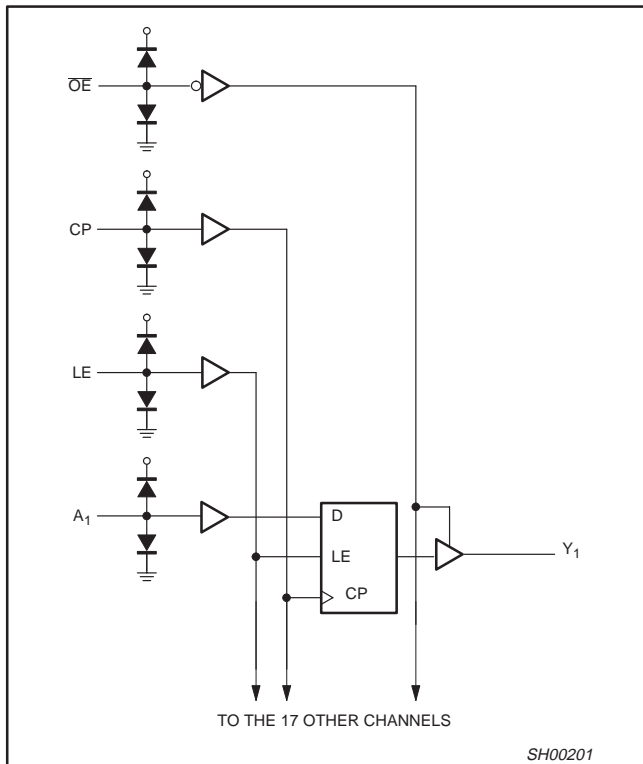

## LOGIC SYMBOL (IEEE/IEC)

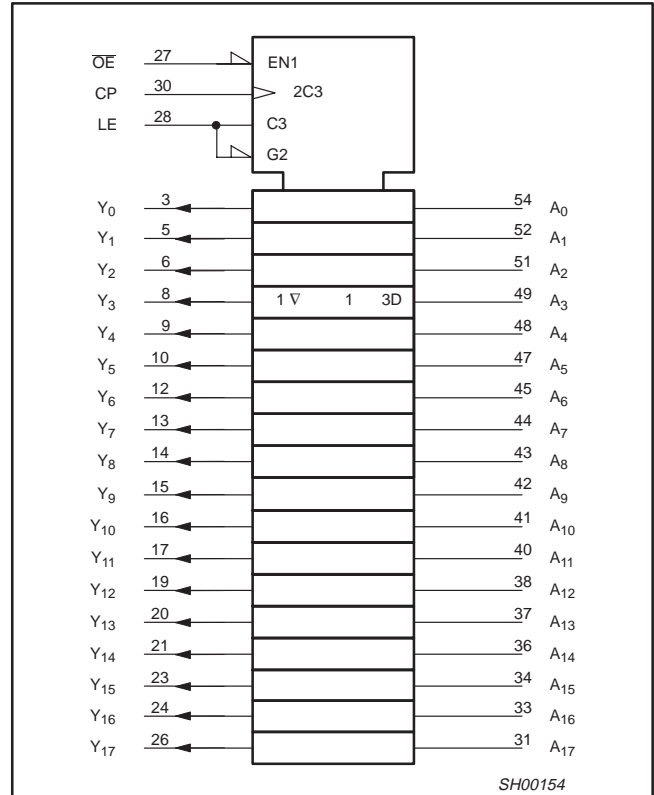

## FUNCTION TABLE

INPUTS				OUTPUTS
OE	LE	CP	A	
H	X	X	X	Z
L	H	X	L	L
L	H	X	H	H
L	L	↑	L	L
L	L	↑	H	H
L	L	H	X	Y <sub>0</sub> <sup>1</sup>
L	L	L	X	Y <sub>0</sub> <sup>2</sup>

- H = HIGH voltage level
- L = LOW voltage level
- X = Don't care
- Z = High impedance "off" state
- ↑ = LOW-to-HIGH level transition

## NOTES:

- Output level before the indicated steady-state input conditions were established, provided that CP is high before LE goes low.
- Output level before the indicated steady-state input conditions were established.

## TYPICAL INPUT (DATA OR CONTROL)

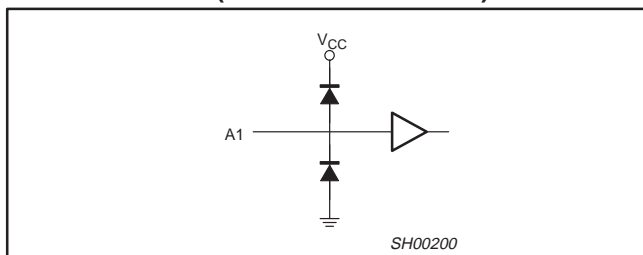

18-bit registered driver with  
Dynamic Controlled Outputs™ (3-State)

74AVC16835A

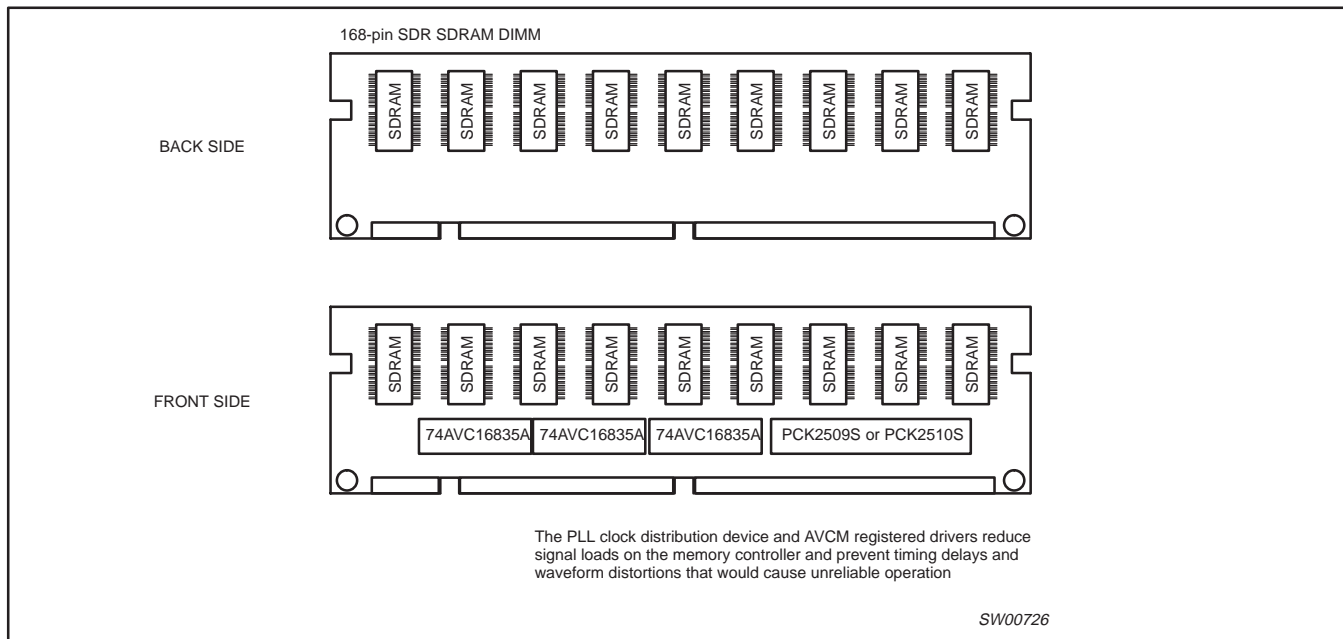

RECOMMENDED OPERATING CONDITIONS

SYMBOL	PARAMETER	CONDITIONS	MIN	MAX	UNIT
V <sub>CC</sub>	DC supply voltage (according to JEDEC Low Voltage Standards)		1.65 2.3 3.0	1.95 2.7 3.6	V
	DC supply voltage (for low voltage applications)		1.2	3.6	V
V <sub>I</sub>	DC Input voltage range		0	3.6	V
V <sub>O</sub>	DC output voltage range; output 3-State		0	3.6	V
	DC output voltage range; output HIGH or LOW state		0	V <sub>CC</sub>	
T <sub>amb</sub>	Operating free-air temperature range		-40	+85	°C
t <sub>r</sub> , t <sub>f</sub>	Input rise and fall times	V <sub>CC</sub> = 1.65 to 2.3 V V <sub>CC</sub> = 2.3 to 3.0 V V <sub>CC</sub> = 3.0 to 3.6 V	0 0 0	30 20 10	ns/V

ABSOLUTE MAXIMUM RATINGS

In accordance with the Absolute Maximum Rating System (IEC 134). Voltages are referenced to GND (ground = 0V).

SYMBOL	PARAMETER	CONDITIONS	RATING	UNIT
V <sub>CC</sub>	DC supply voltage		-0.5 to +4.6	V
I <sub>IK</sub>	DC input diode current	V <sub>I</sub> < 0	-50	mA
V <sub>I</sub>	DC input voltage	For all inputs <sup>1</sup>	-0.5 to 4.6	V
I <sub>OK</sub>	DC output diode current	V <sub>O</sub> > V <sub>CC</sub> or V <sub>O</sub> < 0	±50	mA
V <sub>O</sub>	DC output voltage; output 3-State	Note 1	-0.5 to 4.6	V
V <sub>O</sub>	DC output voltage; output HIGH or LOW state	Note 1	-0.5 to V <sub>CC</sub> + 0.5	V
I <sub>O</sub>	DC output source or sink current	V <sub>O</sub> = 0 to V <sub>CC</sub>	±50	mA
I <sub>GND</sub> , I <sub>CC</sub>	DC V <sub>CC</sub> or GND current		±100	mA
T <sub>stg</sub>	Storage temperature range		-65 to +150	°C
P <sub>TOT</sub>	Power dissipation per package -plastic thin-medium-shrink (TSSOP)	For temperature range: -40 to +125°C above +55°C derate linearly with 8 mW/K	600	mW

NOTE:

1. The input and output voltage ratings may be exceeded if the input and output current ratings are observed.

# 18-bit registered driver with Dynamic Controlled Outputs™ (3-State)

74AVC16835A

## DC ELECTRICAL CHARACTERISTICS

Over recommended operating conditions. Voltage are referenced to GND (ground = 0 V).

SYMBOL	PARAMETER	TEST CONDITIONS	LIMITS			UNIT
			Temp = -40°C to +85°C			
			MIN	TYP <sup>1</sup>	MAX	
V <sub>IH</sub>	HIGH level Input voltage	V <sub>CC</sub> = 1.2 V	V <sub>CC</sub>	–	–	V
		V <sub>CC</sub> = 1.65 to 1.95 V	0.65V <sub>CC</sub>	0.9	–	
		V <sub>CC</sub> = 2.3 to 2.7 V	1.7	1.2	–	
		V <sub>CC</sub> = 3.0 to 3.6 V	2.0	1.5	–	
V <sub>IL</sub>	LOW level Input voltage	V <sub>CC</sub> = 1.2 V	–	–	GND	V
		V <sub>CC</sub> = 1.65 to 1.95 V	–	0.9	0.35V <sub>CC</sub>	
		V <sub>CC</sub> = 2.3 to 2.7 V	–	1.2	0.7	
		V <sub>CC</sub> = 3.0 to 3.6 V	–	1.5	0.8	
V <sub>OH</sub>	HIGH level output voltage	V <sub>CC</sub> = 1.65 to 3.6 V; V <sub>I</sub> = V <sub>IH</sub> or V <sub>IL</sub> ; I <sub>O</sub> = -100 μA	V <sub>CC</sub> - 0.20	V <sub>CC</sub>	–	V
		V <sub>CC</sub> = 1.65 V; V <sub>I</sub> = V <sub>IH</sub> or V <sub>IL</sub> ; I <sub>O</sub> = -4 mA	V <sub>CC</sub> - 0.45	V <sub>CC</sub> - 0.10	–	
		V <sub>CC</sub> = 2.3 V; V <sub>I</sub> = V <sub>IH</sub> or V <sub>IL</sub> ; I <sub>O</sub> = -8 mA	V <sub>CC</sub> - 0.55	V <sub>CC</sub> - 0.28	–	
		V <sub>CC</sub> = 3.0 V; V <sub>I</sub> = V <sub>IH</sub> or V <sub>IL</sub> ; I <sub>O</sub> = -12 mA	V <sub>CC</sub> - 0.70	V <sub>CC</sub> - 0.32	–	
V <sub>OL</sub>	LOW level output voltage	V <sub>CC</sub> = 1.65 to 3.6 V; V <sub>I</sub> = V <sub>IH</sub> or V <sub>IL</sub> ; I <sub>O</sub> = 100 μA	–	GND	0.20	V
		V <sub>CC</sub> = 1.65 V; V <sub>I</sub> = V <sub>IH</sub> or V <sub>IL</sub> ; I <sub>O</sub> = 4 mA	–	0.10	0.45	
		V <sub>CC</sub> = 2.3 V; V <sub>I</sub> = V <sub>IH</sub> or V <sub>IL</sub> ; I <sub>O</sub> = 8 mA	–	0.26	0.55	
		V <sub>CC</sub> = 3.0 V; V <sub>I</sub> = V <sub>IH</sub> or V <sub>IL</sub> ; I <sub>O</sub> = 12 mA	–	0.36	0.70	
I <sub>I</sub>	Input leakage current	V <sub>CC</sub> = 1.65 to 3.6 V; V <sub>I</sub> = V <sub>CC</sub> or GND	–	0.1	2.5	μA
I <sub>OFF</sub>	3-State output OFF-state current	V <sub>CC</sub> = 0 V; V <sub>I</sub> or V <sub>O</sub> = 3.6 V	–	0.1	± 10	μA
I <sub>IHZ</sub> /I <sub>ILZ</sub>	3-State output OFF-state current	V <sub>CC</sub> = 1.65 to 3.6 V; V <sub>I</sub> = V <sub>CC</sub> or GND	–	0.1	12.5	μA
I <sub>OZ</sub>	3-State output OFF-state current	V <sub>CC</sub> = 1.65 to 2.7 V; V <sub>I</sub> = V <sub>IH</sub> or V <sub>IL</sub> ; V <sub>O</sub> = V <sub>CC</sub> or GND	–	0.1	5	μA
		V <sub>CC</sub> = 3.0 to 3.6 V; V <sub>I</sub> = V <sub>IH</sub> or V <sub>IL</sub> ; V <sub>O</sub> = V <sub>CC</sub> or GND	–	0.1	10	
I <sub>CC</sub>	Quiescent supply current	V <sub>CC</sub> = 1.65 to 2.7 V; V <sub>I</sub> = V <sub>CC</sub> or GND; I <sub>O</sub> = 0	–	0.1	20	μA
		V <sub>CC</sub> = 3.0 to 3.6 V; V <sub>I</sub> = V <sub>CC</sub> or GND; I <sub>O</sub> = 0	–	0.2	40	

### NOTE:

1. All typical values are at T<sub>amb</sub> = 25°C.

# 18-bit registered driver with Dynamic Controlled Outputs™ (3-State)

74AVC16835A

## AC CHARACTERISTICS

GND = 0 V;  $t_r = t_f \leq 2.0$  ns;  $C_L = 30$  pF

SYMBOL	PARAMETER	WAVEFORM	LIMITS												UNIT	
			$V_{CC} = 3.3 \pm 0.3$ V			$V_{CC} = 2.5 \pm 0.2$ V			$V_{CC} = 1.8 \pm 0.15$ V			$V_{CC} = 1.5 \pm 0.1$ V		$V_{CC} = 1.5$ V		$V_{CC} = 1.2$ V
			MIN	TYP <sup>1</sup>	MAX	MIN	TYP <sup>1</sup>	MAX	MIN	TYP <sup>1</sup>	MAX	MIN	MAX	TYP		TYP
$t_{PHL}/t_{PLH}$	Propagation delay An to Yn	1	0.9	1.5	2.5	1.0	1.7	3.0	1.3	2.1	4.2	1.6	5.1	3.6	5.2	ns
	Propagation delay LE to Yn	2	0.9	1.6	2.9	1.1	1.9	3.5	1.3	2.2	4.0	1.6	4.6	2.8	4.2	ns
	Propagation delay CP to Yn	3	0.8	1.7	2.7	1.0	1.8	3.0	1.5	2.2	3.7	1.6	4.6	2.9	4.3	ns
$t_{PZH}/t_{PZL}$	3-State output enable time OE to Yn	6	1.2	2.1	4.0	1.5	2.5	4.5	2.2	3.1	5.8	2.5	7.6	4.4	6.3	ns
$t_{PHZ}/t_{PLZ}$	3-State output disable time OE to Yn	6	1.1	2.6	4.8	1.2	2.2	4.5	2.0	3.1	5.6	2.2	7.6	4.1	5.5	ns
$t_w$	CP pulse width HIGH or LOW	3	1.0	–	–	1.2	–	–	2.0	–	–	–	–	–	–	ns
	LE pulse width HIGH	2	1.0	–	–	1.2	–	–	2.0	–	–	–	–	–	–	ns
$t_{SU}$	Set-up time An to CP	5	0	–0.3	–	0	–0.2	–	0	–0.2	–	0.2	–	0	0	ns
	Set-up time An to LE	4	1.0	0.5	–	0.7	0.3	–	1.1	0.6	–	1.6	–	0.9	1.5	ns
$t_h$	Hold time An to CP	5	1.3	0.6	–	0.7	0.3	–	0.7	0.3	–	0.7	–	0.3	0.1	ns
	Hold time An to LE	4	0.3	0.8	–	0.2	0	–	0.2	–0.2	–	0	–	–0.3	–0.7	ns
$f_{max}$	Maximum clock pulse frequency	3	500	–	–	400	–	–	250	–	–	–	–	–	–	MHz

### NOTE:

1. All typical values are measured at  $T_{amb} = 25^\circ\text{C}$  and at  $V_{CC} = 1.8$  V, 2.5 V, 3.3 V.

# 18-bit registered driver with Dynamic Controlled Outputs™ (3-State)

74AVC16835A

## AC WAVEFORMS FOR $V_{CC} = 3.0\text{ V TO }3.6\text{ V}$ RANGE

$V_M = 0.5 V_{CC}$   
 $V_X = V_{OL} + 0.300\text{ V}$   
 $V_Y = V_{OH} - 0.300\text{ V}$   
 $V_{OL}$  and  $V_{OH}$  are the typical output voltage drop that occur with the output load.  
 $V_I = V_{CC}$

## AC WAVEFORMS FOR $V_{CC} = 2.3\text{ V TO }2.7\text{ V}$ AND $V_{CC} < 2.3\text{ V}$ RANGE

$V_M = 0.5 V_{CC}$   
 $V_X = V_{OL} + 0.15\text{ V}$   
 $V_Y = V_{OH} - 0.15\text{ V}$   
 $V_{OL}$  and  $V_{OH}$  are the typical output voltage drop that occur with the output load.  
 $V_I = V_{CC}$

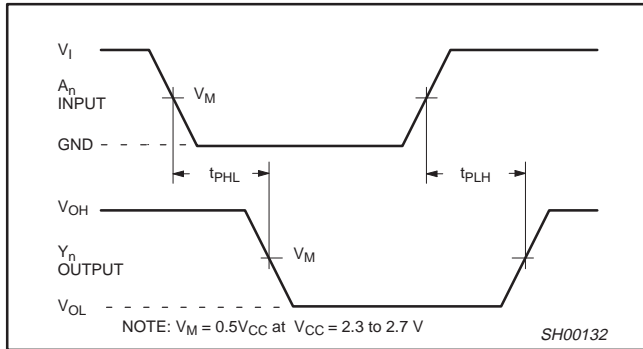

Waveform 1. Input (An) to output (Yn) propagation delay

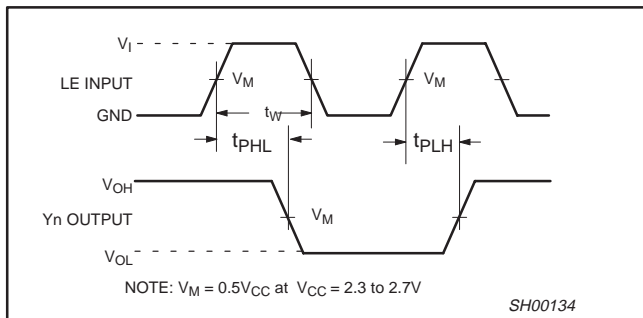

Waveform 2. Latch enable input (LE) pulse width, the latch enable input to output (Yn) propagation delays.

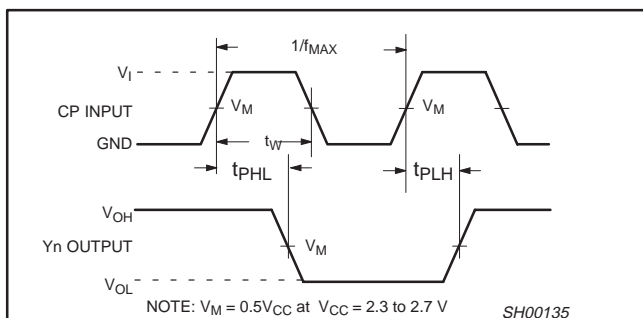

Waveform 3. The clock (CP) to Yn propagation delays, the clock pulse width and the maximum clock frequency.

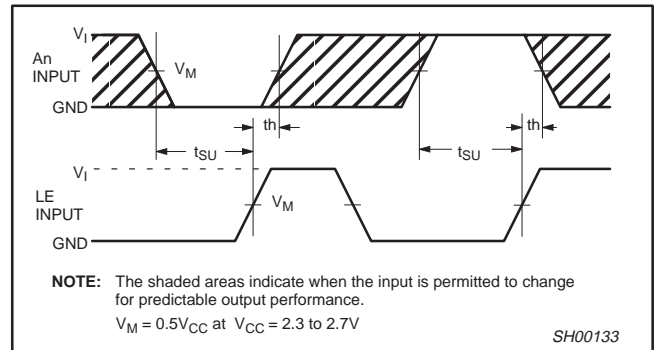

Waveform 4. Data set-up and hold times for the An input to the LE input

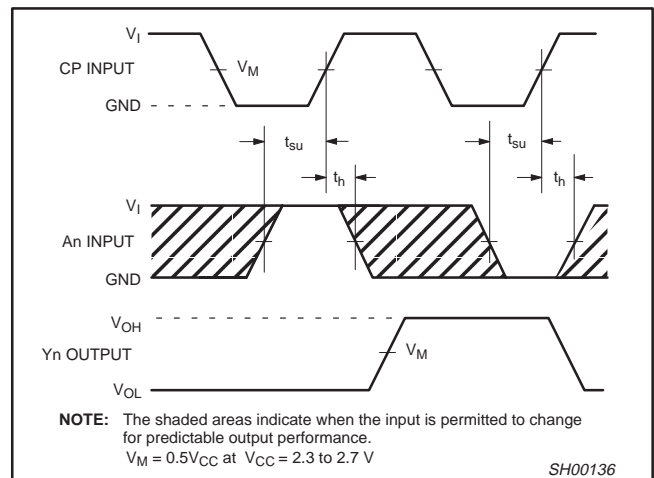

Waveform 5. Data set-up and hold times for the An input to the clock CP input

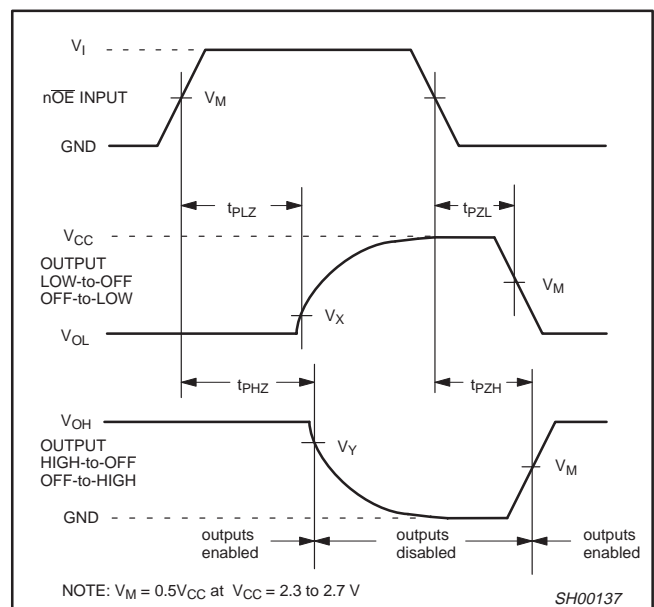

Waveform 6. 3-State enable and disable times

# 18-bit registered driver with Dynamic Controlled Outputs™ (3-State)

74AVC16835A

## TEST CIRCUIT

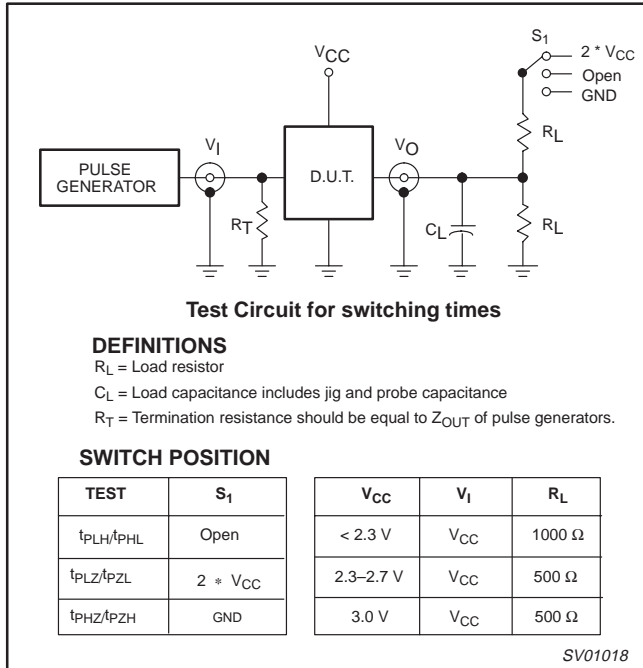

Figure 1. Load circuitry for switching times

## GRAPHS

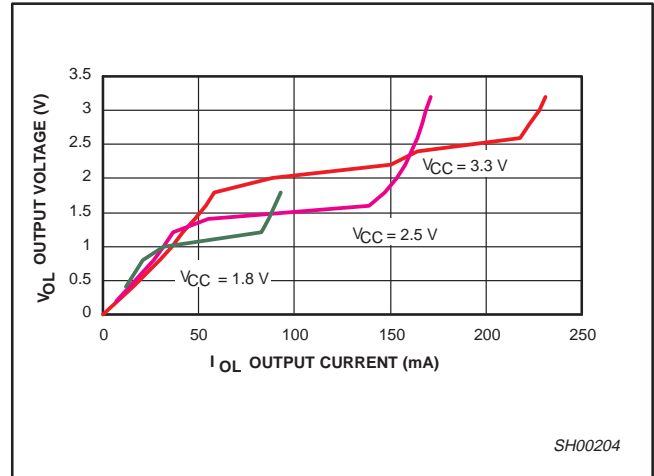

Figure 2. Output voltage ( $V_{OL}$ ) vs. output current ( $I_{OL}$ )

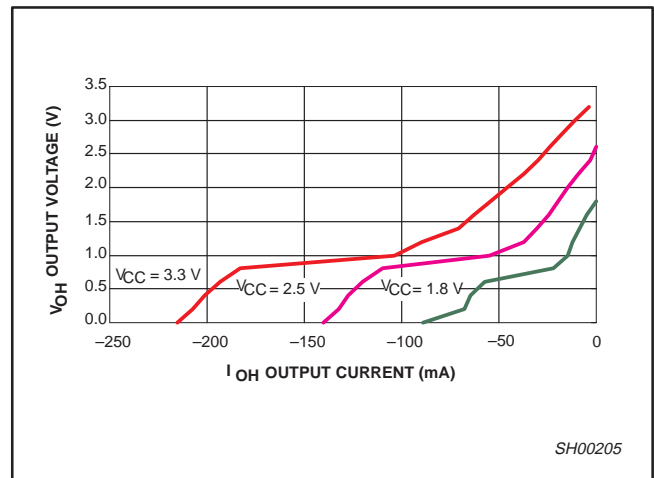

Figure 3. Output voltage ( $V_{OH}$ ) vs. output current ( $I_{OH}$ )

A Dynamic Controlled Output (DCO) circuit is designed in. During the transition, it initially lowers the output impedance to effectively drive the load and, subsequently, raises the impedance to reduce noise. Figures 2 and 3 show  $V_{OL}$  vs.  $I_{OL}$  and  $V_{OH}$  vs.  $I_{OH}$  curves to illustrate the output impedance and drive capability of the circuit. At the beginning of the signal transition, the DCO circuit provides a maximum dynamic drive that is equivalent to a high drive standard output device.

18-bit registered driver with  
[Dynamic Controlled Outputs™](#) (3-State)

74AVC16835A

TSSOP56: plastic thin shrink small outline package; 56 leads; body width 6.1 mm

SOT364-1

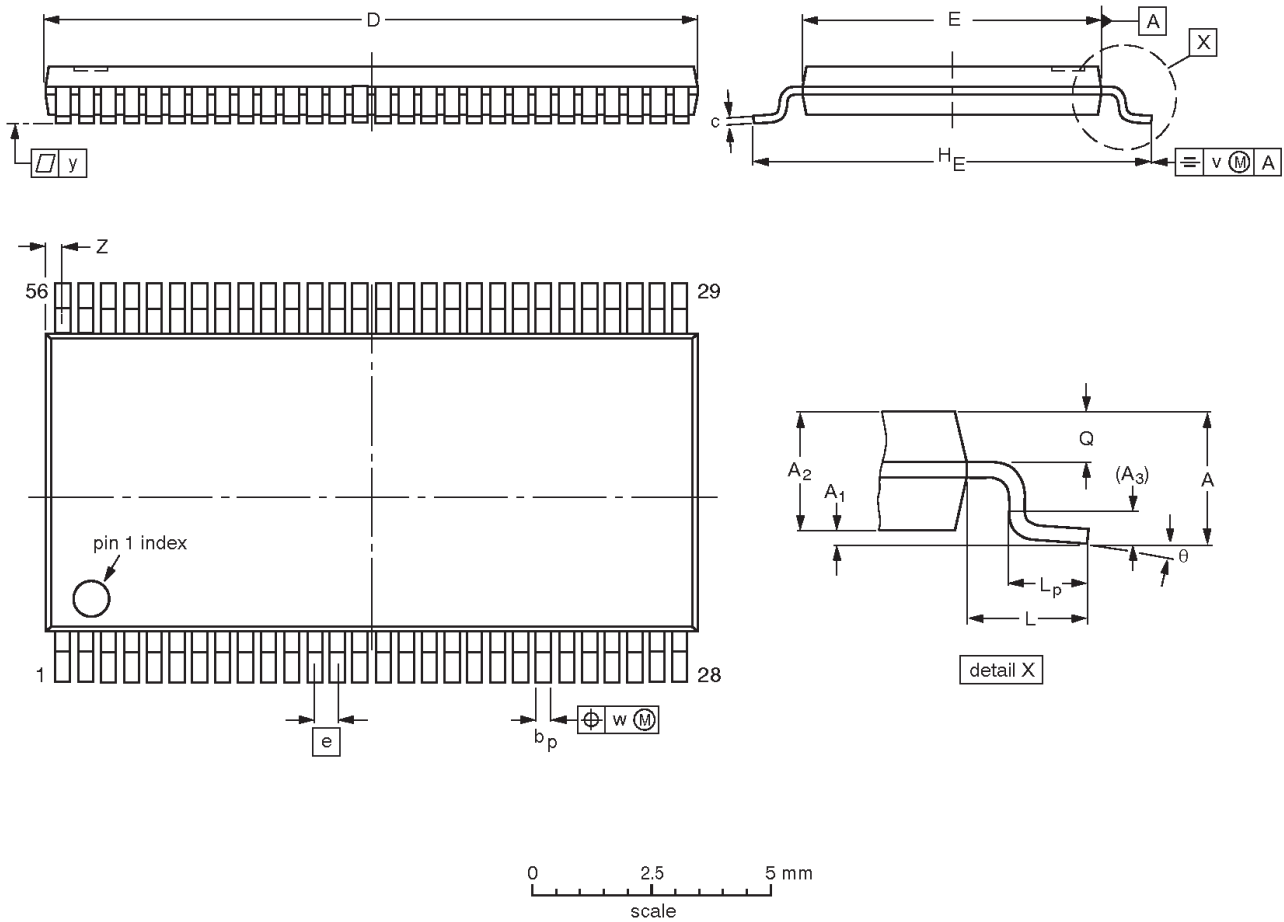

**DIMENSIONS (mm are the original dimensions).**

UNIT	A max.	A <sub>1</sub>	A <sub>2</sub>	A <sub>3</sub>	b <sub>p</sub>	c	D <sup>(1)</sup>	E <sup>(2)</sup>	e	H <sub>E</sub>	L	L <sub>p</sub>	Q	v	w	y	Z	θ
mm	1.2	0.15 0.05	1.05 0.85	0.25	0.28 0.17	0.2 0.1	14.1 13.9	6.2 6.0	0.5	8.3 7.9	1.0	0.8 0.4	0.50 0.35	0.25	0.08	0.1	0.5 0.1	8° 0°

**Notes**

1. Plastic or metal protrusions of 0.15 mm maximum per side are not included.
2. Plastic interlead protrusions of 0.25 mm maximum per side are not included.

OUTLINE VERSION	REFERENCES				EUROPEAN PROJECTION	ISSUE DATE
	IEC	JEDEC	EIAJ			
SOT364-1		MO-153				95-02-10 99-12-27

18-bit registered driver with  
Dynamic Controlled Outputs™ (3-State)

74AVC16835A

TSSOP56: plastic thin shrink small outline package; 56 leads; body width 4.4 mm

SOT481-2

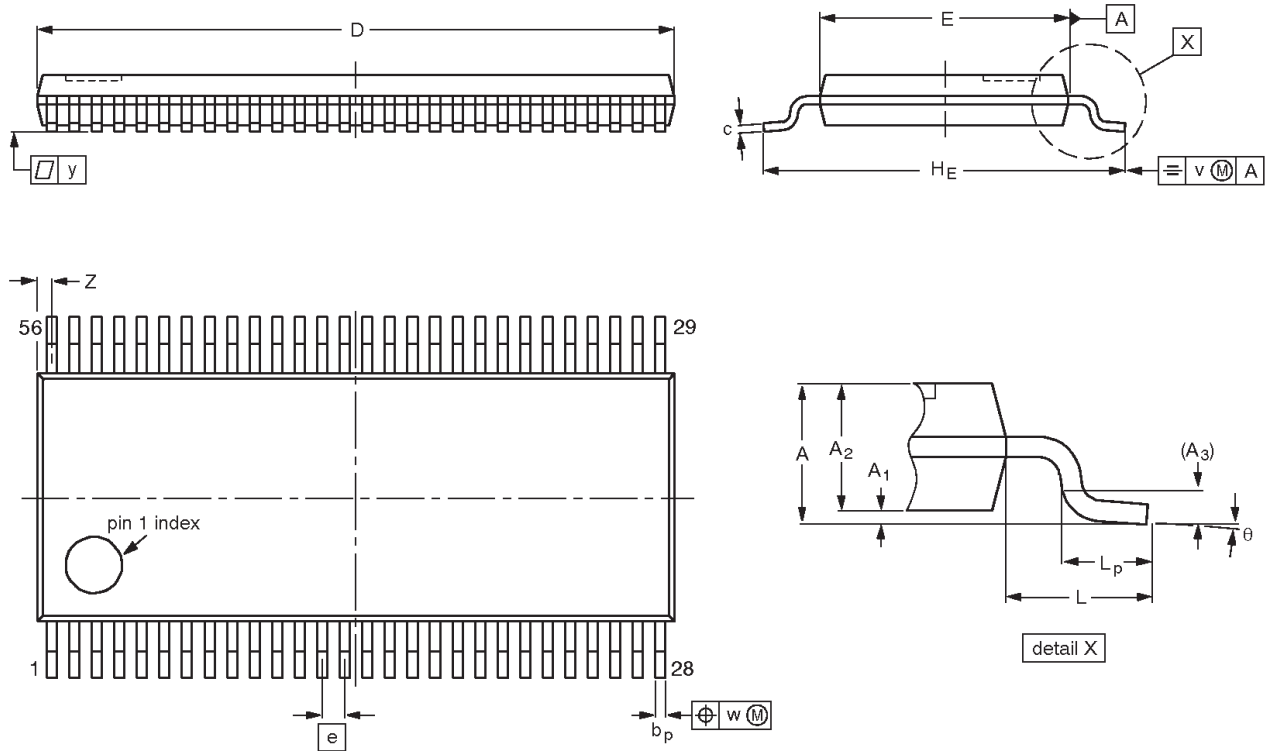

**DIMENSIONS (mm are the original dimensions)**

UNIT	A max.	A <sub>1</sub>	A <sub>2</sub>	A <sub>3</sub>	b <sub>p</sub>	c	D (1)	E (2)	e	H <sub>E</sub>	L	L <sub>p</sub>	v	w	y	Z (1)	θ
mm	1.2	0.15 0.05	1.05 0.80	0.25	0.23 0.13	0.20 0.09	11.4 11.2	4.5 4.3	0.4	6.6 6.2	1	0.75 0.45	0.2	0.07	0.08	0.4 0.1	8° 0°

**Notes**

1. Plastic or metal protrusions of 0.15 mm maximum per side are not included.
2. Plastic or metal protrusions of 0.25 mm maximum per side are not included.

OUTLINE VERSION	REFERENCES				EUROPEAN PROJECTION	ISSUE DATE
	IEC	JEDEC	JEITA			
SOT481-2	---	MO-194	---			01-11-24

---

18-bit registered driver with  
[Dynamic Controlled Outputs™](#) (3-State)

---

74AVC16835A

**NOTES**

# 18-bit registered driver with Dynamic Controlled Outputs™ (3-State)

74AVC16835A

## Data sheet status

Data sheet status <sup>[1]</sup>	Product status <sup>[2]</sup>	Definitions
Objective data	Development	This data sheet contains data from the objective specification for product development. Philips Semiconductors reserves the right to change the specification in any manner without notice.
Preliminary data	Qualification	This data sheet contains data from the preliminary specification. Supplementary data will be published at a later date. Philips Semiconductors reserves the right to change the specification without notice, in order to improve the design and supply the best possible product.
Product data	Production	This data sheet contains data from the product specification. Philips Semiconductors reserves the right to make changes at any time in order to improve the design, manufacturing and supply. Changes will be communicated according to the Customer Product/Process Change Notification (CPCN) procedure SNW-SQ-650A.

[1] Please consult the most recently issued data sheet before initiating or completing a design.

[2] The product status of the device(s) described in this data sheet may have changed since this data sheet was published. The latest information is available on the Internet at URL <http://www.semiconductors.philips.com>.

## Definitions

**Short-form specification** — The data in a short-form specification is extracted from a full data sheet with the same type number and title. For detailed information see the relevant data sheet or data handbook.

**Limiting values definition** — Limiting values given are in accordance with the Absolute Maximum Rating System (IEC 60134). Stress above one or more of the limiting values may cause permanent damage to the device. These are stress ratings only and operation of the device at these or at any other conditions above those given in the Characteristics sections of the specification is not implied. Exposure to limiting values for extended periods may affect device reliability.

**Application information** — Applications that are described herein for any of these products are for illustrative purposes only. Philips Semiconductors make no representation or warranty that such applications will be suitable for the specified use without further testing or modification.

## Disclaimers

**Life support** — These products are not designed for use in life support appliances, devices or systems where malfunction of these products can reasonably be expected to result in personal injury. Philips Semiconductors customers using or selling these products for use in such applications do so at their own risk and agree to fully indemnify Philips Semiconductors for any damages resulting from such application.

**Right to make changes** — Philips Semiconductors reserves the right to make changes, without notice, in the products, including circuits, standard cells, and/or software, described or contained herein in order to improve design and/or performance. Philips Semiconductors assumes no responsibility or liability for the use of any of these products, conveys no license or title under any patent, copyright, or mask work right to these products, and makes no representations or warranties that these products are free from patent, copyright, or mask work right infringement, unless otherwise specified.

## Contact information

For additional information please visit  
<http://www.semiconductors.philips.com>. Fax: +31 40 27 24825

© Koninklijke Philips Electronics N.V. 2002  
All rights reserved. Printed in U.S.A.

Date of release: 03-02

For sales offices addresses send e-mail to:  
[sales.addresses@www.semiconductors.philips.com](mailto:sales.addresses@www.semiconductors.philips.com)

Document order number:

9397 750 09606

*Let's make things better.*