

REVISIONS																			
LTR	DESCRIPTION															DATE (YR-MO-DA)			APPROVED
A	查询"5962-9689301NYD"供应商 Add case outline Y. Update boilerplate to add device class N. Editorial changes throughout. - ro															98-10-28			R. MONNIN

REV																					
SHEET																					
REV	A	A	A	A	A	A	A	A													
SHEET	15	16	17	18	19	20	21	22													
REV STATUS				REV				A	A	A	A	A	A	A	A	A	A	A	A		
OF SHEETS				SHEET				1	2	3	4	5	6	7	8	9	10	11	12	13	14
PMIC N/A				PREPARED BY DAN WONNELL						DEFENSE SUPPLY CENTER COLUMBUS COLUMBUS, OHIO 43216											
STANDARD MICROCIRCUIT DRAWING THIS DRAWING IS AVAILABLE FOR USE BY ALL DEPARTMENTS AND AGENCIES OF THE DEPARTMENT OF DEFENSE AMSC N/A				CHECKED BY RAY MONNIN																	
				APPROVED BY RAY MONNIN						MICROCIRCUIT, LINEAR, 9-CHANNEL DIFFERENTIAL TRANSCEIVER, MONOLITHIC SILICON											
				DRAWING APPROVAL DATE 96-10-15																	
				REVISION LEVEL A						SIZE A	CAGE CODE 67268	5962-96893									
										SHEET 1 OF 22											

DSCC FORM 2233
APR 97

5962-E003-99

DISTRIBUTION STATEMENT A. Approved for public release; distribution is unlimited.

1. SCOPE

查询"5962-9689301NYD"供应商

1.1 Scope. This drawing documents two product assurance class levels consisting of high reliability (device classes Q and M) and space application (device class V) and nontraditional performance environment (device class N). A choice of case outlines and lead finishes are available and are reflected in the Part or Identifying Number (PIN). When available, a choice of Radiation Hardness Assurance (RHA) levels are reflected in the PIN.

1.2 PIN. The PIN is as shown in the following example:

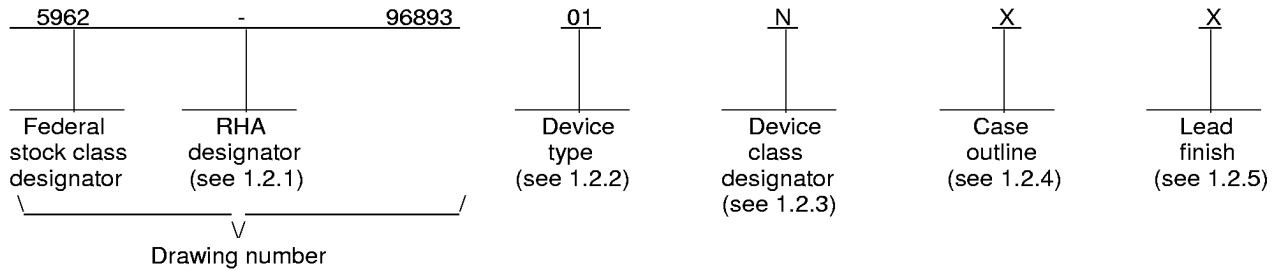

1.2.1 RHA designator. Device classes N, Q, and V RHA marked devices meet the MIL-PRF-38535 specified RHA levels and are marked with the appropriate RHA designator. Device class M RHA marked devices meet the MIL-PRF-38535, appendix A specified RHA levels and are marked with the appropriate RHA designator. A dash (-) indicates a non-RHA device.

1.2.2 Device type(s). The device type(s) identify the circuit function as follows:

Device type	Generic number	Slew limit		Circuit function
		Driver	Receiver	
01	55976A1	8	9	9 Channel Differential Transceiver
02	55976A2	4	5	9 Channel Differential Transceiver

1.2.3 Device class designator. The device class designator is a single letter identifying the product assurance level as follows:

Device class	Device requirements documentation
M	Vendor self-certification to the requirements for MIL-STD-883 compliant, non-JAN class level B microcircuits in accordance with MIL-PRF-38535, appendix A
N	Certification and qualification to MIL-I-38535 with a non-traditional performance environment (encapsulated in plastic)
Q or V	Certification and qualification to MIL-PRF-38535

1.2.4 Case outline(s). The case outline(s) are as designated in MIL-STD-1835 and as follows:

Outline letter	Descriptive designator	Terminals	Package style
X	GDFP1-F56	56	Dual flat pack
Y	See figure 1	56	Plastic small outline package

1.2.5 Lead finish. The lead finish is as specified in MIL-PRF-38535 for device classes N, Q, and V or MIL-PRF-38535, appendix A for device class M.

STANDARD MICROCIRCUIT DRAWING DEFENSE SUPPLY CENTER COLUMBUS COLUMBUS, OHIO 43216-5000	SIZE A		5962-96893
		REVISION LEVEL A	SHEET 2

HANDBOOKS
查询"5962-9689301NYD"供应商

DEPARTMENT OF DEFENSE

- MIL-HDBK-103 - List of Standard Microcircuit Drawings (SMD's).
- MIL-HDBK-780 - Standard Microcircuit Drawings.

(Unless otherwise indicated, copies of the specification, standards, and handbooks are available from the Standardization Document Order Desk, 700 Robbins Avenue, Building 4D, Philadelphia, PA 19111-5094.)

2.2 Non-Government publications. The following documents form a part of this document to the extent specified herein. Unless otherwise specified, the issues of the documents which are DoD adopted are those listed in the issue of the DODISS cited in the solicitation. Unless otherwise specified, the issues of documents not listed in the DODISS are the issues of the documents cited in the solicitation.

ELECTRONICS INDUSTRIES ASSOCIATION (EIA)

JEDEC Publication 95 - Registered and Standard Outlines for Semiconductor Devices.

(Applications for copies should be addressed to the Electronics Industries Association, 2500 Wilson Boulevard, Arlington, VA 22201-3834).

(Non-Government standards and other publications are normally available from the organizations that prepare or distribute the documents. These documents also may be available in or through libraries or other informational services.)

2.3 Order of precedence. In the event of a conflict between the text of this drawing and the references cited herein, the text of this drawing takes precedence. Nothing in this document, however, supersedes applicable laws and regulations unless a specific exemption has been obtained.

3. REQUIREMENTS

3.1 Item requirements. The individual item requirements for device classes N, Q, and V shall be in accordance with MIL-PRF-38535 and as specified herein or as modified in the device manufacturer's Quality Management (QM) plan. The modification in the QM plan shall not affect the form, fit, or function as described herein. The individual item requirements for device class M shall be in accordance with MIL-PRF-38535, appendix A for non-JAN class level B devices and as specified herein.

3.2 Design, construction, and physical dimensions. The design, construction, and physical dimensions shall be as specified in MIL-PRF-38535 and herein for device classes N, Q, and V or MIL-PRF-38535, appendix A and herein for device class M.

3.2.1 Case outline(s). The case outline(s) shall be in accordance with 1.2.4 herein and figure 1.

3.2.2 Terminal connections. The terminal connections shall be as specified on figure 2.

3.2.3 Truth table(s). The truth table(s) shall be as specified on figure 3.

3.3 Electrical performance characteristics and postirradiation parameter limits. Unless otherwise specified herein, the electrical performance characteristics and postirradiation parameter limits are as specified in table I and shall apply over the full ambient operating temperature range.

3.4 Electrical test requirements. The electrical test requirements shall be the subgroups specified in table II. The electrical tests for each subgroup are defined in table I.

STANDARD MICROCIRCUIT DRAWING DEFENSE SUPPLY CENTER COLUMBUS COLUMBUS, OHIO 43216-5000	SIZE A		5962-96893
		REVISION LEVEL A	SHEET 4

DSCC FORM 2234
APR 97

3.5 Marking. The part shall be marked with the PIN listed in 1.2 herein. In addition, the manufacturer's PIN may also be marked as listed in MIL-HDBK-103. For packages where marking of the entire SMD PIN number is not feasible due to space limitations, the manufacturer has the option of not marking the "5962-" on the device. For RHA product using this option, the RHA designator shall still be marked. Marking for device classes Q and V shall be in accordance with MIL-PRF-38535. Marking for device class M shall be in accordance with MIL-PRF-38535, appendix A.

3.5.1 Marking for device class N. For PEM packages MIL-PRF-38535 marking is not required. Marking on the device shall include; a traceable date code, country of origin, pin one indicator, and manufacturers identification. In addition, the QML certification mark and the PIN as shown in 1.2 herein shall be marked on the topside of the package. Manufacturer may at their option place the QML certification mark adjacent to the PIN. In all cases, the purchase order shall reflect the SMD PIN as shown in 1.2 herein.

3.5.2 Certification/compliance mark. The certification mark for device classes N, Q, and V shall be a "QML" or "Q" as required in MIL-PRF-38535. The compliance mark for device class M shall be a "C" as required in MIL-PRF-38535, appendix A.

3.6 Certificate of compliance. For device classes N, Q, and V, a certificate of compliance shall be required from a QML-38535 listed manufacturer in order to supply to the requirements of this drawing (see 6.6.1 herein). For device class M, a certificate of compliance shall be required from a manufacturer in order to be listed as an approved source of supply in MIL-HDBK-103 (see 6.6.2 herein). The certificate of compliance submitted to DSCC-VA prior to listing as an approved source of supply for this drawing shall affirm that the manufacturer's product meets, for device classes N, Q, and V, the requirements of MIL-PRF-38535 and herein or for device class M, the requirements of MIL-PRF-38535, appendix A and herein.

3.7 Certificate of conformance. A certificate of conformance as required for device classes N, Q, and V in MIL-PRF-38535 or for device class M in MIL-PRF-38535, appendix A shall be provided with each lot of microcircuits delivered to this drawing.

3.8 Notification of change for device class M. For device class M, notification to DSCC-VA of change of product (see 6.2 herein) involving devices acquired to this drawing is required for any change as defined in MIL-STD-973.

3.9 Verification and review for device class M. For device class M, DSCC, DSCC's agent, and the acquiring activity retain the option to review the manufacturer's facility and applicable required documentation. Offshore documentation shall be made available onshore at the option of the reviewer.

3.10 Microcircuit group assignment for device class M. Device class M devices covered by this drawing shall be in microcircuit group number 77 (see MIL-PRF-38535, appendix A).

STANDARD MICROCIRCUIT DRAWING DEFENSE SUPPLY CENTER COLUMBUS COLUMBUS, OHIO 43216-5000	SIZE A		5962-96893
		REVISION LEVEL A	SHEET 5

DSCC FORM 2234
APR 97

TABLE I. Electrical performance characteristics.

Test and MIL-STD-883 test method <u>1/</u>	Symbol	Test conditions <u>2/</u> -55°C ≤ T _A ≤ +125°C +4.75 V ≤ V _{CC} ≤ +5.25 V unless otherwise specified		V _{CC}	Device type	Group A subgroups	Limits <u>3/</u>		Unit
							Min	Max	
Driver differential high-level output voltage	V _{ODH}	S1 to A, see figure 3	V _T = 5 V	4.75 V to 5.25 V	All	1	1.0		V
						2, 3	0.7		
		S1 to B, see figure 3				1	0.8		
						2, 3	0.7		
Driver differential low-level output voltage	V _{ODL}	S1 to B, see figure 3	V _T = 5 V	4.75 V to 5.25 V	All	1		-1.0	V
						2, 3		-0.7	
		S1 to A, see figure 3				1		-0.8	
						2, 3		-0.7	
High level output voltage	V _{OH}	A side, V _{ID} = 200 mV see figure 4	I _{OH} = -8 mA	4.75 V to 5.25 V	All	1, 2, 3	4.0		V
Low level output voltage	V _{OL}	A side, V _{ID} = -200 mV see figure 4	I _{OL} = 8 mA	4.75 V to 5.25 V	All	1, 2, 3		0.8	V
Receiver positive differential input threshold voltage	V _{IT+}	I _{OH} = -8 mA, see figure 4		4.75 V to 5.25 V	All	1, 2, 3		0.2	V
Receiver negative differential input threshold voltage	V _{IT-}	I _{OL} = 8 mA, see figure 4		4.75 V to 5.25 V	All	1, 2, 3		-0.2	V
Receiver input hysteresis (V _{IT+} - V _{IT-})	V _{hys}	T _A = 25°C		5.0 V	All	1	24.0		mV

See footnotes at end of table.

STANDARD MICROCIRCUIT DRAWING DEFENSE SUPPLY CENTER COLUMBUS COLUMBUS, OHIO 43216-5000	SIZE A		5962-96893
		REVISION LEVEL A	SHEET 6

TABLE I. Electrical performance characteristics - Continued.

Test and MIL-STD-883 test method <u>1/</u>	Symbol	Test conditions <u>2/</u> -55°C ≤ T _A ≤ +125°C +4.75 V ≤ V _{CC} ≤ +5.25 V unless otherwise specified		V _{CC}	Device type	Group A subgroups	Limits <u>3/</u>		Unit
							Min	Max	
Bus input current	I _I	V _{IH} = 12 V, Other input at 0 V		5.0 V	All	1, 2, 3		1.0	mA
				0.0 V			1.0		
		V _{IH} = -7 V, Other input at 0 V		5.0 V				-0.8	
				0.0 V				-0.8	
High-level input current	I _{IH}	A, BSR, CRE, and DE/RE	V _{IH} = 2.0 V	4.75 V to 5.25 V	All	1, 2, 3		-100	μA
		CDE0, CDE1 and CDE2					+100		
Low-level input current	I _{IL}	A, BSR, CRE, and DE/RE	V _{IH} = 0.8 V	4.75 V to 5.25 V	All	1, 2, 3		-100	μA
		CDE1, CDE1 and CDE2					+100		
Short circuit output current	I _{OS}	nB+ or nB-		4.75 V to 5.25 V	All	1, 2, 3		±260	mA
Supply current	I _{CC}	Disabled		4.75 V to 5.25 V	All	1, 2, 3		10.0	mA
		All drivers enabled, no load		5.25 V				60.0	
		All receivers enabled, no load						45.0	
Driver switching characteristics									
Functional test 3014	<u>4/</u>	V _{IH} = 2.0 V, V _{IL} = 0.8 V Verify output V _O see 4.4.1b		4.75 V to 5.25 V	All	7, 8	L	H	

See footnotes at end of table.

STANDARD MICROCIRCUIT DRAWING DEFENSE SUPPLY CENTER COLUMBUS COLUMBUS, OHIO 43216-5000	SIZE A		5962-96893
		REVISION LEVEL A	SHEET 7

TABLE I. Electrical performance characteristics - Continued.

Test and MIL-STD-883 test method <u>1/</u>	Symbol	Test conditions <u>2/</u> -55°C ≤ T _A ≤ +125°C +4.75 V ≤ V _{CC} ≤ +5.25 V unless otherwise specified	V _{CC}	Device type	Group A subgroups	Limits <u>3/</u>		Unit
						Min	Max	
Driver switching characteristics - continued								
Propagation delay time, t _{PHL} or t _{PLH}	t _{pd}	See figure 3	5.0 V	01	9	3.0	11.0	ns
					10, 11		15.0	
				02	9	5.0	9.0	
					10, 11		13.5	
Skew limit, maximum t _{pd} - minimum t _{pd}	t _{sk(lim)}		4.75 V to	01	9, 10, 11		8.0	ns
	<u>5/</u>		5.25 V	02			4.0	
Pulse skew, t _{PHL} - t _{PLH}	t _{sk(p)}		4.75 V to 5.25 V	All	9, 10, 11		4.0	ns
Enable time, control inputs to active output	t _{en}		4.75 V to	All	9		50.0	ns
			5.25 V				10, 11	
Disable time, control inputs to high impedance output	t _{dis}		4.75 V to	All	9		100	ns
			5.25 V				10, 11	
Propagation delay time, high-level to high impedance output	t _{PHZ}	see figure 5	4.75 V to	All	9		100	ns
			5.25 V				10, 11	
Propagation delay time, low-level to high impedance output	t _{PLZ}	see figure 5	4.75 V to	All	9		100	ns
			5.25 V				10, 11	

See footnotes at end of table.

STANDARD MICROCIRCUIT DRAWING DEFENSE SUPPLY CENTER COLUMBUS COLUMBUS, OHIO 43216-5000	SIZE A		5962-96893
		REVISION LEVEL A	SHEET 8

查询"5962-9689301NYD"供应商

TABLE I. Electrical performance characteristics - Continued.

Test and MIL-STD-883 test method <u>1/</u>	Symbol	Test conditions <u>2/</u> -55°C ≤ T _A ≤ +125°C +4.75 V ≤ V _{CC} ≤ +5.25 V unless otherwise specified	V _{CC}	Device type	Group A subgroups	Limits <u>3/</u>		Unit
						Min	Max	

Driver switching characteristics - continued

Propagation delay time, high impedance to high-level output	t _{PZH}	see figure 5	4.75 V to 5.25 V	All	9		50.0	ns
					10, 11		60.0	
Propagation delay time, high impedance to low-level output	t _{PZL}		4.75 V to 5.25 V		9		50.0	
					10, 11		60.0	

Receiver switching characteristics

Functional test 3014	<u>4/</u>	V _{IH} = 2.0 V, V _{IL} = 0.8 V Verify output V _O see 4.4.1b	4.75 V to 5.25 V	All	7, 8	L	H		
Propagation delay time, t _{PHL} or t _{PLH}	t _{pd}	see figure 4	5.0 V	01	9	7.5	16.5	ns	
					10, 11		19.0		
					02	9	8.6		13.6
					10, 11		16.0		
Skew limit, maximum t _{pd} - minimum t _{pd}	t _{sk(lim)}		4.75 V to 5.25 V	01	9, 10, 11		9.0	ns	
	<u>5/</u>			02			5.0		
Pulse skew, t _{PHL} - t _{PLH}	t _{sk(p)}		4.75 V to 5.25 V	All	9, 10, 11		4.0	ns	
Enable time, control inputs to active output	t _{en}		4.75 V to 5.25 V	All	9		50.0	ns	
					10, 11		70.0		

See footnotes at end of table.

STANDARD MICROCIRCUIT DRAWING DEFENSE SUPPLY CENTER COLUMBUS COLUMBUS, OHIO 43216-5000	SIZE A		5962-96893
		REVISION LEVEL A	SHEET 9

DSCC FORM 2234
APR 97

TABLE I. Electrical performance characteristics - Continued.

Test and MIL-STD-883 test method <u>1/</u>	Symbol	Test conditions <u>2/</u> -55° C ≤ T _A ≤ +125° C +4.75 V ≤ V _{CC} ≤ +5.25 V unless otherwise specified	V _{CC}	Device type	Group A subgroups	Limits <u>3/</u>		Unit
						Min	Max	
Receiver switching characteristics - continued								
Disable time, control inputs to high-impedance output	t _{dis}		4.75 V to 5.25 V	All	9		60.0	ns
					10, 11		80.0	
Propagation delay time, high-level to high impedance output	t _{PHZ}	See figure 6	4.75 V to 5.25 V	All	9		60.0	ns
					10, 11		80.0	
Propagation delay time, low-level to high impedance output	t _{PLZ}		4.75 V to 5.25 V		9		50.0	
					10, 11		70.0	
Propagation delay time, high impedance to high-level output	t _{PZH}	See figure 6	4.75 V to 5.25 V	All	9		50.0	ns
					10, 11		70.0	
Propagation delay time, high impedance to low-level output	t _{PZL}		4.75 V to 5.25 V		9		50.0	
					10, 11		70.0	

- 1/ For tests not listed in the referenced MIL-STD-883, utilize the general test procedure of 883 under the conditions listed herein.
- 2/ Each input/output, as applicable, shall be tested at the specified temperature, for the specified limits, to the tests in table I herein. Output terminals not designated shall be high level logic, low level logic, or open, except for all I_{CC} tests, where the output terminals shall be open. When performing these tests, the current meter shall be placed in the circuit such that all current flows through the meter.
- 3/ For negative and positive voltage and current values, the sign designates the potential difference in reference to GND and the direction of current flow, respectively; and the absolute value of the magnitude, not the sign, is relative to the minimum and maximum limits, as applicable, listed herein.
- 4/ Tests shall be performed in sequence, attributes data only. Functional tests shall include the truth table and other logic patterns used for fault detection. The test vectors used to verify the truth table shall, at a minimum, test all functions of each input and output. All possible input to output logic patterns per function shall be guaranteed, if not tested, to the truth table in figure 2 herein. Functional tests shall be performed in sequence as approved by the qualifying activity on qualified devices. After incorporating allowable tolerances per MIL-STD-883, V_{IL} = 0.4 V and V_{IH} = 2.4 V. For outputs, L ≤ 0.8 V, H ≥ 2.0 V.
- 5/ This parameter is applicable at one V_{CC} and operating temperature within the recommended operating conditions and to any two devices.

STANDARD MICROCIRCUIT DRAWING DEFENSE SUPPLY CENTER COLUMBUS COLUMBUS, OHIO 43216-5000	SIZE A		5962-96893
		REVISION LEVEL A	SHEET 10

DSCC FORM 2234
APR 97

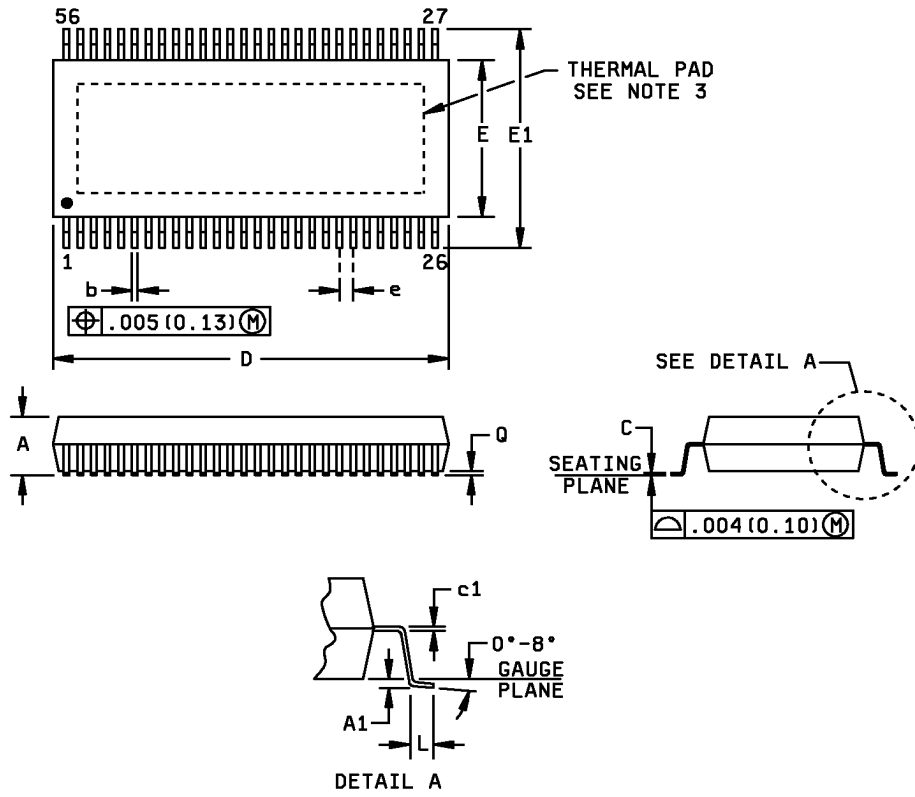

FIGURE 1. Case outline.

STANDARD MICROCIRCUIT DRAWING DEFENSE SUPPLY CENTER COLUMBUS COLUMBUS, OHIO 43216-5000	SIZE A		5962-96893
		REVISION LEVEL A	SHEET 11

Symbol	Millimeters		Notes
	Min	Max	
A	---	1.20	
A1	0.25	---	
b	0.170	0.270	
C	0.10	---	
c1	0.15	---	
D	13.90	14.10	
E	6.00	6.20	
E1	7.90	8.30	
e	0.500	---	
L	0.500	0.750	
Q	0.50	0.150	

NOTES:

1. Body dimensions do not include mold flash or protrusion not to exceed 0.15 mm.
2. The package thermal performance may be enhanced by bonding the thermal pad to an external thermal plane. This pad is electrically and thermally connected to the backside of the die possibly selected leads.

FIGURE 1. Case outline - Continued.

STANDARD MICROCIRCUIT DRAWING DEFENSE SUPPLY CENTER COLUMBUS COLUMBUS, OHIO 43216-5000	SIZE A		5962-96893
		REVISION LEVEL A	SHEET 12

[查询"5962-9689301NYD"供应商](#)

Device types		01 and 02	
Case outlines		X and Y	
Terminal number	Terminal symbol	Terminal number	Terminal symbol
1	GND	29	1B-
2	BSR	30	1B+
3	$\overline{\text{CRE}}$	31	2B-
4	1A	32	2B+
5	1DE/ $\overline{\text{RE}}$	33	3B-
6	2A	34	3B+
7	2DE/ $\overline{\text{RE}}$	35	4B-
8	3A	36	4B+
9	3DE/ $\overline{\text{RE}}$	37	5B-
10	4A	38	5B+
11	4DE/ $\overline{\text{RE}}$	39	V _{cc}
12	V _{cc}	40	GND
13	GND	41	GND
14	GND	42	GND
15	GND	43	GND
16	GND	44	GND
17	GND	45	V _{cc}
18	V _{cc}	46	6B-
19	5A	47	6B+
20	5DE/ $\overline{\text{RE}}$	48	7B-
21	6A	49	7B+
22	6DE/ $\overline{\text{RE}}$	50	8B-
23	7A	51	8B+
24	7DE/ $\overline{\text{RE}}$	52	9B-
25	8A	53	9B+
26	8DE/ $\overline{\text{RE}}$	54	CDE0
27	9A	55	CDE1
28	9DE/ $\overline{\text{RE}}$	56	CDE2

FIGURE 2. Terminal connections.

STANDARD MICROCIRCUIT DRAWING DEFENSE SUPPLY CENTER COLUMBUS COLUMBUS, OHIO 43216-5000	SIZE A		5962-96893
		REVISION LEVEL A	SHEET 13

DSCC FORM 2234
APR 97

Terminal Functions				
Terminal	Logic level	I/O	Termination	Description
mA (m = 1 to 9)	TTL	I/O	Pullup	1A to 9A carry data to and from the communication controller.
mB- (m = 1 to 9)	RS-485	I/O	Pulldown	1B- to 9B- are the inverted data signals of the balanced pair to/from the bus.
mB+ (m = 1 to 9)	RS-485	I/O	Pullup	1B+ to 9B+ are the noninverted data signals of the balanced pair to/from the bus.
BSR	TTL	Input	Pullup	BSR is the bit significant response. BSR disables receivers 1 through 8 and enables wired-OR drivers when BSR and DE/ \overline{RE} and CDE1 or CDE2 are high. Channel 9 is placed in a high-impedance state with BSR high.
CDE0	TTL	Input	Pulldown	CDE0 is the common driver enable 0. Its input signal enables all drivers when CDE0 and $1\overline{DE}/\overline{RE}$ - $9\overline{DE}/\overline{RE}$ are high.
CDE1	TTL	Input	Pulldown	CDE1 is the common driver enable 1. Its input signal enables drivers 1 to 4 when CDE1 is high and BSR is low.
CDE2	TTL	Input	Pulldown	CDE2 is the common driver enable 2. When CDE2 is high and BSR is low, drivers 5 to 8 are enabled.
\overline{CRE}	TTL	Input	Pullup	\overline{CRE} is the common receiver enable. When high, \overline{CRE} disables receiver channels 5 to 9.
$m\overline{DE}/\overline{RE}$ (m = 1 to 9)	TTL	Input	Pullup	$1\overline{DE}/\overline{RE}$ - $9\overline{DE}/\overline{RE}$ are direction controls that transmit data to the bus when it and CDE0 are high. Data is received from the bus when $1\overline{DE}/\overline{RE}$ - $9\overline{DE}/\overline{RE}$ and \overline{CRE} and BSR are low and CDE1 and CDE2 are low.

FIGURE 2. Terminal connections - Continued.

STANDARD MICROCIRCUIT DRAWING DEFENSE SUPPLY CENTER COLUMBUS COLUMBUS, OHIO 43216-5000	SIZE A		5962-96893
		REVISION LEVEL A	SHEET 14

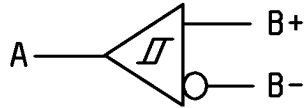

INPUTS		OUTPUT
B+ ^{1/}	B- ^{1/}	A
L	H	L
H	L	H

DRIVER

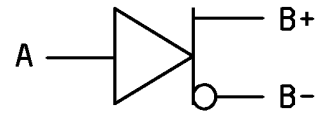

INPUT	OUTPUTS	
	B+	B-
A	L	H
L	L	H
H	H	L

TRANSCEIVER

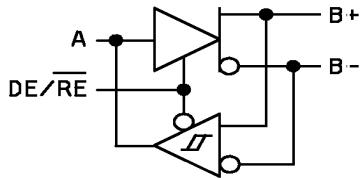

INPUTS				OUTPUTS		
DE/RE	A	B+ ^{1/}	B- ^{1/}	A	B+	B-
L	-	L	H	L	-	-
L	-	H	L	H	-	-
H	L	-	-	-	L	H
H	H	-	-	-	H	L

DRIVER WITH ENABLE

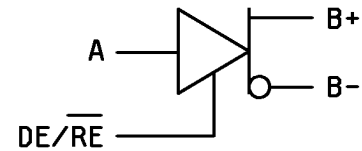

INPUTS		OUTPUTS	
DE/RE	A	B+	B-
L	L	Z	Z
L	H	Z	Z
H	L	L	H
H	H	H	L

WIRED-OR DRIVER

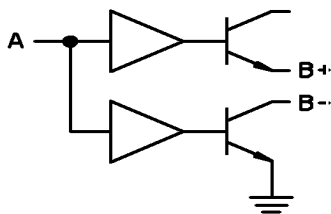

INPUT	OUTPUTS	
	B+	B-
A	L	H
L	Z	Z
H	H	L

TWO-ENABLE INPUT DRIVER

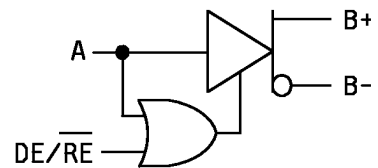

INPUTS		OUTPUTS	
DE/RE	A	B+	B-
L	L	Z	Z
L	H	H	L
H	L	L	H
H	H	H	L

NOTES: H = high level, L = low level, Z = high impedance (off).

^{1/} "H" in this column represents a voltage of 200 mV or higher than the other bus input. "L" represents a voltage of 200 mV or lower than the other bus input. Any voltage less than 200 mV results in an indeterminate receiver output.

FIGURE 3. Truth table.

<p>STANDARD MICROCIRCUIT DRAWING DEFENSE SUPPLY CENTER COLUMBUS COLUMBUS, OHIO 43216-5000</p>	<p>SIZE A</p>		<p>5962-96893</p>
		<p>REVISION LEVEL A</p>	<p>SHEET 15</p>

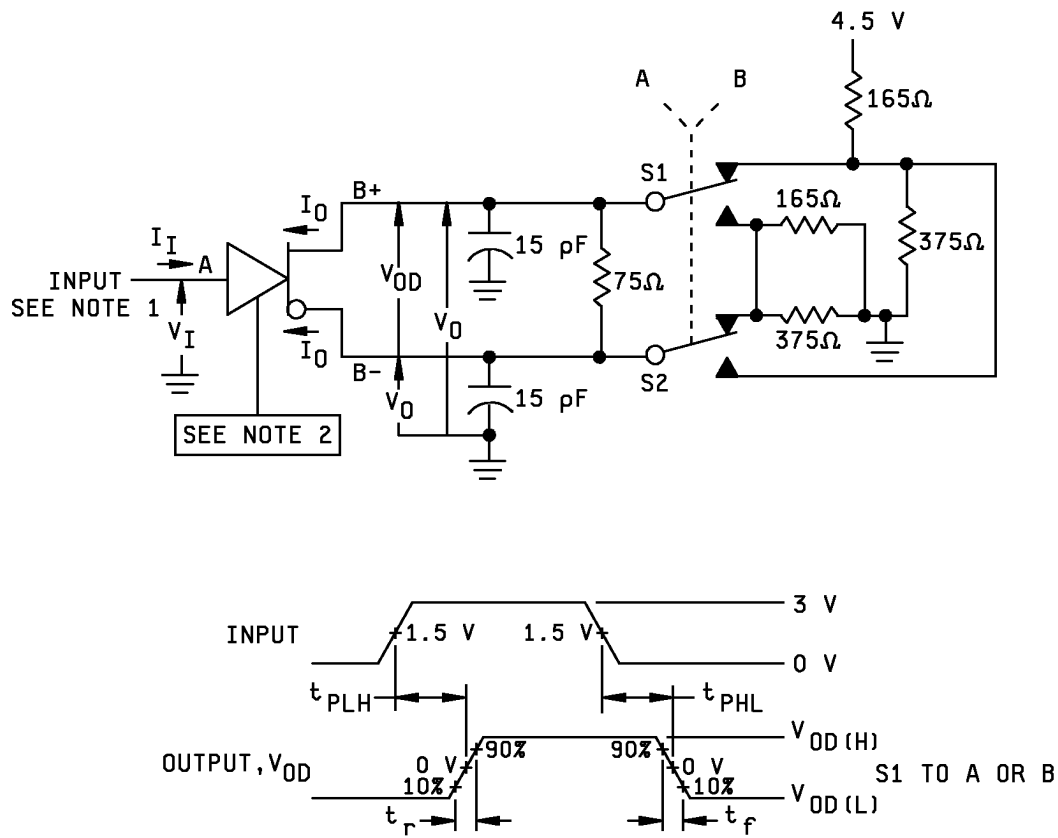

NOTES:

1. All input pulses are supplied by a generator having the following characteristics: $t_r \leq 6$ ns, $t_f \leq 6$ ns, PRR ≤ 1 MHz, duty cycle = 50%, $Z_0 = 50 \Omega$.
2. CDE0 and DE/ \overline{RE} are at 2 V, BSR is at 0.8 V.
3. All resistances are $\pm 5\%$, unless otherwise indicated.
4. All capacitances are $\pm 10\%$, unless otherwise indicated.
5. All indicated voltages are ± 10 mV.

FIGURE 4. Driver delay and transition test circuit and timing waveforms.

STANDARD MICROCIRCUIT DRAWING DEFENSE SUPPLY CENTER COLUMBUS COLUMBUS, OHIO 43216-5000	SIZE A		5962-96893
		REVISION LEVEL A	SHEET 16

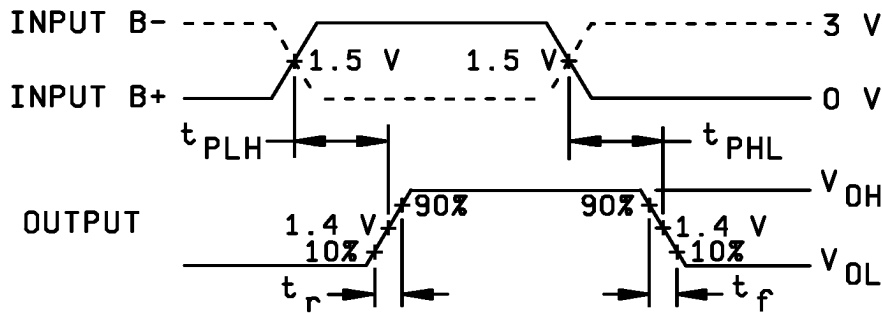
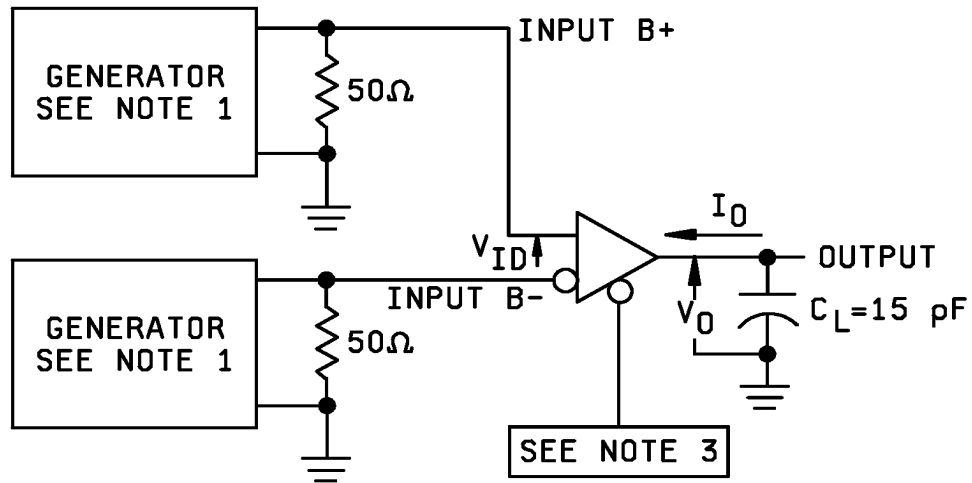

NOTES:

1. All input pulses are supplied by a generator having the following characteristics: $t_r \leq 6 \text{ ns}$, $t_f \leq 6 \text{ ns}$, $\text{PRR} \leq 1 \text{ MHz}$, duty cycle = 50%, $Z_o = 50 \Omega$.
2. All indicated voltages are $\pm 10 \text{ mV}$.
3. CDE0, CDE1, CDE2, BSR, CRE, and DE/RE at 0.8 V.
4. All resistances are $\pm 5\%$, unless otherwise indicated.
5. All capacitances are $\pm 10\%$, unless otherwise indicated.

FIGURE 5. Receiver delay and transition test circuit and timing waveforms.

STANDARD MICROCIRCUIT DRAWING DEFENSE SUPPLY CENTER COLUMBUS COLUMBUS, OHIO 43216-5000	SIZE A		5962-96893
		REVISION LEVEL A	SHEET 17

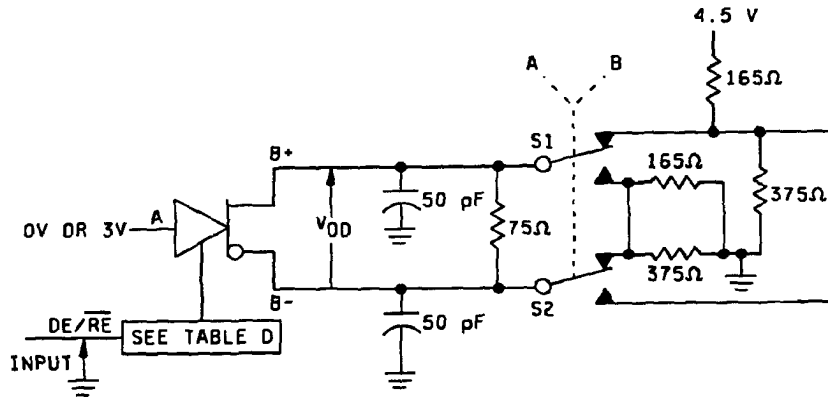
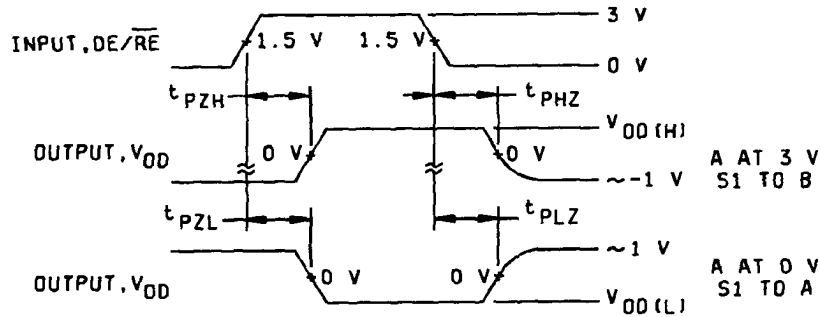

TABLE D. Enabling for driver enable and disable time.

DRIVER	BSR	CDE0	CDE1	CDE2	CRE
1 - 8	H	H	L	L	X
9	L	H	H	H	H



NOTES:

1. All input pulses are supplied by a generator having the following characteristics: $t_r \leq 6$ ns, $t_f \leq 6$ ns, PRR ≤ 1 MHz, duty cycle = 50%, $Z_o = 50 \Omega$.
2. All indicated voltages are ± 10 mV.
3. All resistances are $\pm 5\%$, unless otherwise indicated.
4. All capacitances are $\pm 10\%$, unless otherwise indicated.

FIGURE 6. Driver enable and disable time test circuit and timing waveforms. – Continued

STANDARD MICROCIRCUIT DRAWING DEFENSE SUPPLY CENTER COLUMBUS COLUMBUS, OHIO 43216-5000	SIZE A		5962-96893
		REVISION LEVEL A	SHEET 18

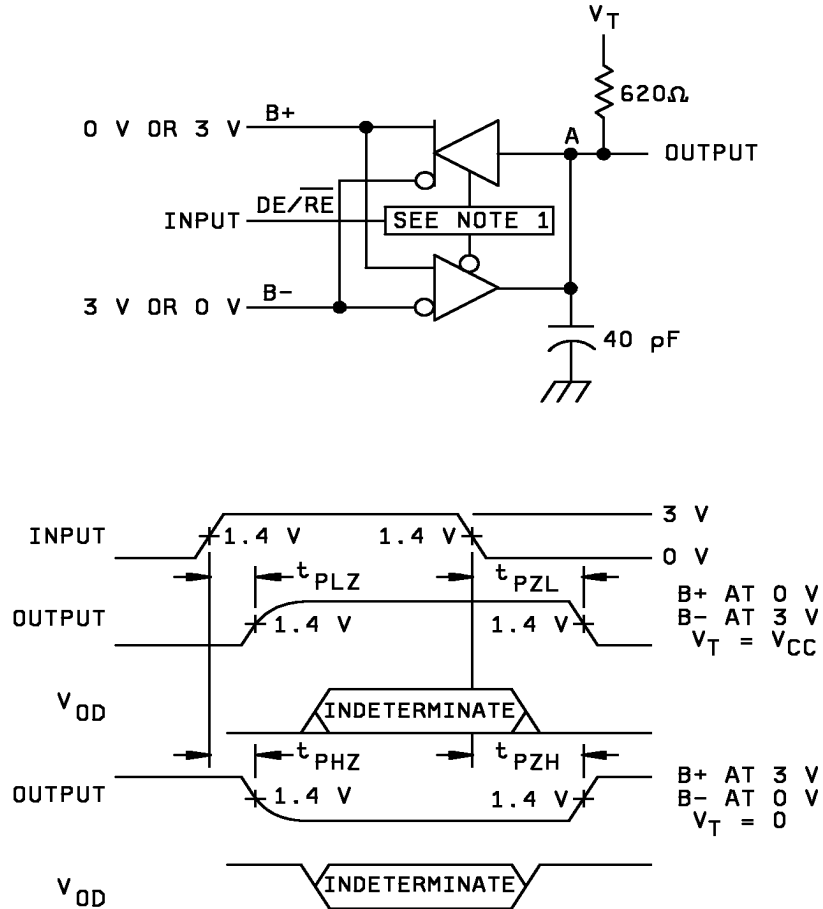

NOTES:

1. CDE0 is high, CDE1, CDE2, BSR, and CRE are low.
2. All input pulses are supplied by a generator having the following characteristics: $t_r \leq 6$ ns, $t_f \leq 6$ ns, PRR ≤ 1 MHz, duty cycle = 50%, $Z_o = 50 \Omega$.
3. All indicated voltages are ± 10 mV.
4. All resistances are $\pm 5\%$, unless otherwise indicated.
5. All capacitances are $\pm 10\%$, unless otherwise indicated.

FIGURE 6. Receiver enable and disable time test circuit and timing waveforms.

STANDARD MICROCIRCUIT DRAWING DEFENSE SUPPLY CENTER COLUMBUS COLUMBUS, OHIO 43216-5000	SIZE A		5962-96893
		REVISION LEVEL A	SHEET 19

4. QUALITY ASSURANCE PROVISIONS

[查询“5962-9689301NYD”供应商](#)

4.1 Sampling and inspection. For device classes N, Q, and V, sampling and inspection procedures shall be in accordance with MIL-PRF-38535 or as modified in the device manufacturer's Quality Management (QM) plan. The modification in the QM plan shall not affect the form, fit, or function as described herein. For device class M, sampling and inspection procedures shall be in accordance with MIL-PRF-38535, appendix A.

4.2 Screening. For device classes N, Q, and V, screening shall be in accordance with MIL-PRF-38535, and shall be conducted on all devices prior to qualification and technology conformance inspection. For device class M, screening shall be in accordance with method 5004 of MIL-STD-883, and shall be conducted on all devices prior to quality conformance inspection.

4.2.1 Additional criteria for device class M.

- a. Burn-in test, method 1015 of MIL-STD-883.
 - (1) Test condition A, B, C, or D. The test circuit shall be maintained by the manufacturer under document revision level control and shall be made available to the preparing or acquiring activity upon request. The test circuit shall specify the inputs, outputs, biases, and power dissipation, as applicable, in accordance with the intent specified in test method 1015.
 - (2) $T_A = +125^\circ\text{C}$, minimum.
- b. Interim and final electrical test parameters shall be as specified in table II herein.

4.2.2 Additional criteria for device classes N, Q, and V.

- a. The burn-in test duration, test condition and test temperature, or approved alternatives shall be as specified in the device manufacturer's QM plan in accordance with MIL-PRF-38535. The burn-in test circuit shall be maintained under document revision level control of the device manufacturer's Technology Review Board (TRB) in accordance with MIL-PRF-38535 and shall be made available to the acquiring or preparing activity upon request. The test circuit shall specify the inputs, outputs, biases, and power dissipation, as applicable, in accordance with the intent specified in test method 1015 of MIL-STD-883.
- b. Interim and final electrical test parameters shall be as specified in table II herein.
- c. Additional screening for device class V beyond the requirements of device class Q shall be as specified in MIL-PRF-38535, appendix B.

4.3 Qualification inspection for device classes N, Q, and V. Qualification inspection for device classes N, Q, and V shall be in accordance with MIL-PRF-38535. Inspections to be performed shall be those specified in MIL-PRF-38535 and herein for groups A, B, C, D, and E inspections (see 4.4.1 through 4.4.4).

4.4 Conformance inspection. Technology conformance inspection for classes N, Q, and V shall be in accordance with MIL-PRF-38535 including groups A, B, C, D, and E inspections and as specified herein except where option 2 of MIL-PRF-38535 permits alternate in-line control testing. Quality conformance inspection for device class M shall be in accordance with MIL-PRF-38535, appendix A and as specified herein. Inspections to be performed for device class M shall be those specified in method 5005 of MIL-STD-883 and herein for groups A, B, C, D, and E inspections (see 4.4.1 through 4.4.4).

4.4.1 Group A inspection.

- a. Tests shall be as specified in table II herein.
- b. For device class M, subgroups 7 and 8 tests shall be sufficient to verify the truth table. For device classes N and Q, subgroups 7 and 8 tests shall be sufficient to verify the truth table.

STANDARD MICROCIRCUIT DRAWING DEFENSE SUPPLY CENTER COLUMBUS COLUMBUS, OHIO 43216-5000	SIZE A		5962-96893
		REVISION LEVEL A	SHEET 20

TABLE II. Electrical test requirements.

Test requirements	Subgroups (in accordance with MIL-STD-883, method 5005, table I)	Subgroups (in accordance with MIL-PRF-38535, table III)		
	Device class M	Device class N	Device class Q	Device class V
Interim electrical parameters (see 4.2)	---	---	---	1
Final electrical parameters (see 4.2)	1,2,3,7,8, <u>1/</u> 9,10,11	1,2,3,7,8, <u>1/</u> 9,10,11	1,2,3,7,8, <u>1/</u> 9,10,11	1,2,3,7,8, <u>1/</u> 9,10,11
Group A test requirements (see 4.4)	1,2,3,4,7, 8,9,10,11	1,2,3,4,7, 8,9,10,11	1,2,3,4,7, 8,9,10,11	1,2,3,4,7, 8,9,10,11
Group C end-point electrical parameters (see 4.4)	1,2,3	1,2,3	1,2,3	1,2,3
Group D end-point electrical parameters (see 4.4)	1,2,3	1,2,3	1,2,3	1,2,3
Group E end-point electrical parameters (see 4.4)	1,7,9	1,7,9	1,7,9	1,7,9

1/ PDA applies to subgroup 1.
2/ PDA applies to subgroups 1 and 7.

4.4.2 Group C inspection. The group C inspection end-point electrical parameters shall be as specified in table II herein.

4.4.2.1 Additional criteria for device class M. Steady-state life test conditions, method 1005 of MIL-STD-883:

- a. Test condition A, B, C, or D. The test circuit shall be maintained by the manufacturer under document revision level control and shall be made available to the preparing or acquiring activity upon request. The test circuit shall specify the inputs, outputs, biases, and power dissipation, as applicable, in accordance with the intent specified in test method 1005 of MIL-STD-883.
- b. T_A = +125° C, minimum.
- c. Test duration: 1,000 hours, except as permitted by method 1005 of MIL-STD-883.

4.4.2.2 Additional criteria for device classes N, Q, and V. The steady-state life test duration, test condition and test temperature, or approved alternatives shall be as specified in the device manufacturer's QM plan in accordance with MIL-PRF-38535. The test circuit shall be maintained under document revision level control by the device manufacturer's TRB in accordance with MIL-PRF-38535 and shall be made available to the acquiring or preparing activity upon request. The test circuit shall specify the inputs, outputs, biases, and power dissipation, as applicable, in accordance with the intent specified in test method 1005 of MIL-STD-883.

4.4.3 Group D inspection. The group D inspection end-point electrical parameters shall be as specified in table II herein.

STANDARD MICROCIRCUIT DRAWING DEFENSE SUPPLY CENTER COLUMBUS COLUMBUS, OHIO 43216-5000	SIZE A		5962-96893
		REVISION LEVEL A	SHEET 21

4.4.4. Group E inspection. Group E inspection is required only for parts intended to be marked as radiation hardness assured (see 3.5 herein).

- a. End-point electrical parameters shall be as specified in table II herein.
- b. For device classes N, Q, and V, the devices or test vehicle shall be subjected to radiation hardness assured tests as specified in MIL-PRF-38535 for the RHA level being tested. For device class M, the devices shall be subjected to radiation hardness assured tests as specified in MIL-PRF-38535, appendix A for the RHA level being tested. All device classes must meet the postirradiation end-point electrical parameter limits as defined in table I at $T_A = +25^\circ\text{C} \pm 5^\circ\text{C}$, after exposure, to the subgroups specified in table II herein.
- c. When specified in the purchase order or contract, a copy of the RHA delta limits shall be supplied.

5. PACKAGING

5.1 Packaging requirements. The requirements for packaging shall be in accordance with MIL-PRF-38535 for device classes Q and V or MIL-PRF-38535, appendix A for device class M.

6. NOTES

6.1 Intended use. Microcircuits conforming to this drawing are intended for use for Government microcircuit applications (original equipment), design applications, and logistics purposes.

6.1.1 Replaceability. Microcircuits covered by this drawing will replace the same generic device covered by a contractor prepared specification or drawing.

6.1.2 Substitutability. Device class Q devices will replace device class M devices.

6.2 Configuration control of SMD's. All proposed changes to existing SMD's will be coordinated with the users of record for the individual documents. This coordination will be accomplished in accordance with MIL-STD-973 using DD Form 1692, Engineering Change Proposal.

6.3 Record of users. Military and industrial users should inform Defense Supply Center Columbus when a system application requires configuration control and which SMD's are applicable to that system. DSCC will maintain a record of users and this list will be used for coordination and distribution of changes to the drawings. Users of drawings covering microelectronic devices (FSC 5962) should contact DSCC-VA, telephone (614) 692-0525.

6.4 Comments. Comments on this drawing should be directed to DSCC-VA , Columbus, Ohio 43216-5000, or telephone (614) 692-0674.

6.5 Abbreviations, symbols, and definitions. The abbreviations, symbols, and definitions used herein are defined in MIL-PRF-38535 and MIL-HDBK-1331.

6.6 Sources of supply.

6.6.1 Sources of supply for device classes N, Q, and V. Sources of supply for device classes Q and V are listed in QML-38535. The vendors listed in QML-38535 have submitted a certificate of compliance (see 3.6 herein) to DSCC-VA and have agreed to this drawing.

6.6.2 Approved sources of supply for device class M. Approved sources of supply for class M are listed in MIL-HDBK-103. The vendors listed in MIL-HDBK-103 have agreed to this drawing and a certificate of compliance (see 3.6 herein) has been submitted to and accepted by DSCC-VA.

STANDARD MICROCIRCUIT DRAWING DEFENSE SUPPLY CENTER COLUMBUS COLUMBUS, OHIO 43216-5000	SIZE A		5962-96893
		REVISION LEVEL A	SHEET 22

DSCC FORM 2234
APR 97

DATE: 98-10-28

Approved sources of supply for SMD 5962-96893 are listed below for immediate acquisition information only and shall be added to MIL-HDBK-103 and QML-38535 during the next revision. MIL-HDBK-103 and QML-38535 will be revised to include the addition or deletion of sources. The vendors listed below have agreed to this drawing and a certificate of compliance has been submitted to and accepted by DSCC-VA. This bulletin is superseded by the next dated revision of MIL-HDBK-103 and QML-38535.

Standard microcircuit drawing PIN <u>1/</u>	Vendor CAGE number	Vendor similar PIN <u>2/</u>
5962-9689301NYD	01295	SNJ55976A1DCA
5962-9689301QXA	01295	SNJ55976A1WD
5962-9689302NYD	01295	SNJ55976A2DCA
5962-9689302QXA	01295	SNJ55976A2WD

- 1/ The lead finish shown for each PIN representing a hermetic package is the most readily available from the manufacturer listed for that part. If the desired lead finish is not listed, contact the vendor to determine its availability.
- 2/ Caution. Do not use this number for item acquisition. Items acquired to this number may not satisfy the performance requirements of this drawing.

Vendor CAGE number

01295

Vendor name and address

Texas Instruments Incorporated
6412 Highway 75 South
Sherman, TX 75090-0084

The information contained herein is disseminated for convenience only and the Government assumes no liability whatsoever for any inaccuracies in the information bulletin.